



Figure 1. Physical Photo of TEC9V6AD

## FEATURES

- **Built-in Auto PID Control – the World’s First**
- **Maximum Output Voltage Swing:  $\pm 7.2V$**
- **Maximum Output Current: 6A**
- **High Efficiency: > 92%**  
@ $V_{VPS} = 9V$  &  $V_{TEC} = 6V$  &  $I_{TEC} = 6A$
- **High Temperature Stability:  $< \pm 0.001^{\circ}C$**
- Reduced Thermistor Injection Current:  $< 1\mu A$
- Continuous Bi-directional Output
- Programmable Output Current and Voltage Limits
- TEC Temperature, Current and Voltage Signals
- Selectable Temperature Sensor Types: thermistor, RTD, or temperature sensor IC
- High Reliability and Zero EMI
- Compact Size:  $35.96 \times 35.96 \times 8.2$  (mm)
- 100 % lead (Pb)-free and RoHS compliant

## APPLICATIONS

Driving high power TEC modules at high efficiency without tuning the compensation network manually.

## DESCRIPTION

TEC (Thermo-Electric Cooler) is a semiconductor device which can cool down or heat up the temperature of an object by injecting an electrical current in one or the other direction. This TEC controller, TEC9V6A, is designed to drive a TEC at high efficiency for regulating the object temperature precisely by controlling the direction and magnitude of the current going through the TEC. It is powered by a DC voltage between 5.5V to 9V and the output current

can go up to 6A without using a heat sink. Figure 1 is photos of the actual controller TEC9V6AD, one shows the signal pins, and the other shows the power pins.

The controller TEC9V6A allows setting the set-point temperature, maximum output voltage magnitude, and the maximum output current magnitude respectively. These three settings are the input parameters for the three control loops: constant temperature, constant current, and constant voltage. Before hitting the maximum output voltage magnitude or the maximum output current magnitude, the temperature loop is in control. When hitting the maximum output voltage magnitude, either outputting a positive or negative value across the TEC, the voltage loop takes over the control, the controller will be outputting a constant voltage to the TEC; when hitting the maximum output current magnitude, the current loop takes over the control, the controller will be outputting a constant output current to the TEC. The highest output voltage magnitude is limited by the maximum power supply voltage, and the maximum output current magnitude is 6A.

The temperature signal can be obtained by using one of these 3 temperature sensors: thermistor, RTD or temperature sensor IC. When using a thermistor, the set-point temperature range is determined by an external temperature network formed by 3 resistors. In order to reduce the injection current to the thermistor to reduce the errors caused by the self-heating effect, the injection current is provided in pulse mode, reducing the current by 10 times as opposed to a continuous current.

One advanced feature of this TEC controller is that it comes with a smart auto PID control micro-processor which senses and compensates for the thermal load automatically at real time, without needing external components to form a compensation network, nor requiring to fine tune the network with load tediously. The TEC controller with auto PID has a part number: TEC9V6ADAPID for the DIP package & TEC9V6ASAPID for the SMT package.

Conservative users can still choose using the conventional analog compensation network. The same as in the past, it requires a one-time pre-tuning the network to match the thermal load, but provides reliable and high accuracy control. For fixed thermal load applications, conventional analog compensation might be a good choice, while for applications with variable or numerous types of thermal loads, the automatic PID control is more suitable.

Figure 2 is the top view of the controller, showing the pin names and the locations. There are a total of 32

pins in 2mm pitch. All the pins on the left are for either control input or indication output signals; all the right pins are power input or output.

The pin function details are given in Table 1.

At the thermistor input, there is a linearization circuit for the thermistor, to make the temperature output voltage be more linearly proportional to the actual thermistor temperature. There is a voltage inverter circuit, and it makes the temperature output voltage be positively proportional to the temperature, since the thermistor has a negative temperature coefficient. These 2 circuits together are called temperature measurement circuit. See Figure 6.

The set-point temperature voltage and the voltage representing the actual temperature are sent to an error amplifier. There is a compensation network inserted in the loop, to stop the oscillation of the controller caused by phase delay effects of the thermal load. Therefore, the compensation network must match the need for driving a particular thermal load. To simplify the tuning, a tunable compensation network is provided by the evaluation board for this TEC controller. A detailed guidance about how to tune the compensation network with a thermal load is given in the evaluation board application note.

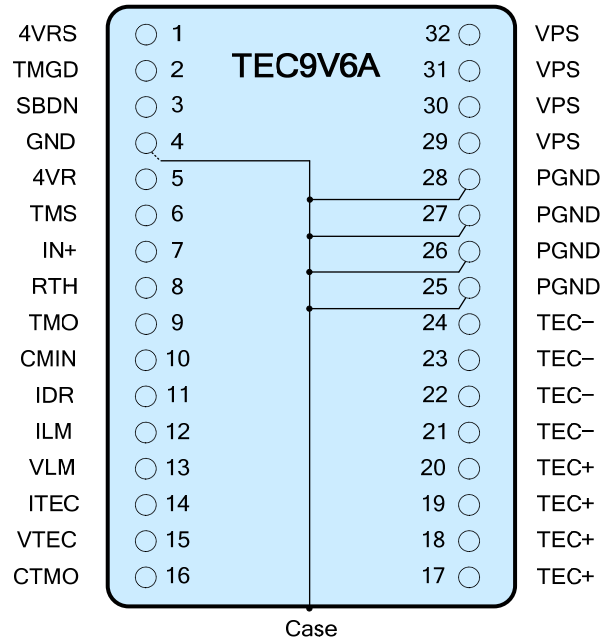

Figure 2. Pin Names and Location

## SPECIFICATIONS

Table 1. Pin Function Descriptions

Pin #	Name	Note	Description
1*	<b>4VRS</b>	Analog output	4VR switch output. This pin outputs a switching pulse 4VR signal, from 0V to 4V, 85Hz, as a reference for the thermistor.
	<b>SNCO</b>	Digital output	Synchronization output. This pin outputs a switching pulse signal, from 0V to 5V, 600kHz. It can be sent to the synchronization input of another SM (Switch Mode) controller or power supply, to eliminate the beating interference between this TEC controller and the other SM device.
2	<b>TMGD</b>	Digital output	<p>Temperature good indication. Active high. Indicates when actual temperature equals to the set-point temperature of the target object. That is, the target object temperature is within 0.001°C away from the set-point temperature, provided the set-point temperature range is 40°C. Or <math> V_{TMO}-V_{TMS}  &lt; 0.5mV</math>.</p> <p><b>For the controller with PID function:</b></p> <p>When the voltage of Pin 16 CTMO is 4V: when TMGD indicator is flashing, it indicates that it is identifying PID coefficient, and when this indicator is always on, the PID coefficient has been identified.</p>



Pin #	Name	Note	Description
3	<b>SBDN</b>	Analog /Digital input	Standby and shut down control. This SBDN pin is internally floated and series with 1k resistor. It's suggested to pull this pin up to VPS power supply by a 4.99MΩ resistor. If pulled to ground, it shuts down the entire controller. This pin has 2 threshold voltages: 1.5V and 2.0V. See Figure 5. SHUT DOWN: $V_{SBDN} < 0.3V$ , the controller is set to non-working state. STANDBY: $1.9V > V_{SBDN} > 1.5V$ , all components are set to working state except the output stages for TEC+ and TEC-. OPERATION: $V_{SBDN} > 2.0V$ , the whole controller is set to working state.
4	<b>GND</b>	Ground	Signal ground. Connect this pin to the signal ground of ADCs, DACs, and the signal sources. It can also be used as analog output pin ground.
5	<b>4VR</b>	Analog output	Reference voltage output, 4.096V. It can be used as the voltage reference by the potentiometers or DACs for setting the analog ports, such as TMS, ILM, VLM, etc. It can also be used by ADCs for sensing the analog output ports: TMO, CTMO, ITEC and VTEC. The initial accuracy is 0.1%, and the temperature coefficient is <50ppm/°C max.
6	<b>TMS</b>	Analog input	Analog Input port for setting the set-point temperature for the target object. It is internally tied a 1MΩ resistor to the half value of the reference voltage, 2V. The open circuit voltage of this pin is thus 2V, corresponding to a set-point temperature of 25°C by using the default temperature network (with the set-point temperature range being from 15°C to 35°C). It is highly recommended to set this pin's voltage by using the controller's 4V voltage reference. This pin can be set by using a POT or DAC. When the set-point temperature needs to be at 25°C, leave this pin unconnected.
7	<b>IN+</b>	Analog input	Receive external temperature signal (thermistor and temperature sensor, etc.)
8	<b>RTH</b>	Analog input	Thermistor connection port. Connect to the thermistor which is mounted on the target object for sensing its temperature. By using the default internal temperature network, a 10kΩ @ 25°C thermistor can be used. Other type of thermistors or temperature sensors can also be used, see the application section for details.
9	<b>TMO</b>	Analog output	Actual target object temperature indication. It swings from 0V to 4V. By using a default internal temperature network, it represents 15°C to 35°C when this pin's voltage swings 0.1V to 3.9V linearly, provided a standard 10kΩ thermistor is used as the temperature sensor device.
10	<b>CMIN</b>	Analog input	Compensation input pin for the thermal control loop.
11	<b>IDR</b>	Analog input and output	This voltage is derived from the temperature error detection circuit and used as the input control signal of the current loop for the TEC. Its internal impedance is 10kΩ and can be over-driven by an external analog signal which is able to over-ride the 10kΩ resistor. The voltage range is from 0V to 4V, corresponding to -6A to +6A output current. Setting this pin voltage to 2V forces the output current to zero.



Pin #	Name	Note	Description
12	<b>ILM</b>	Analog input	This pin sets the TEC Current Limit. The maximum limit current is 6A. Setting this pin's voltage from 0V to 4V corresponds to setting the current magnitude limit from 0A to 6A: $V_{ILM} = \frac{ I_{OUT}(A) _{MAX}}{3.75}$
13	<b>VLM</b>	Analog input	This pin sets the TEC voltage Limit. The maximum limit voltage is 30V. Setting this pin's voltage from 0V to 4V corresponds to the TEC voltage magnitude limit being from 0 to 30V: $V_{VLM} = \frac{ V_{TEC+} - V_{TEC-} _{MAX}}{7.5}$
14	<b>ITEC</b>	Analog output	TEC current indication. ITEC is an analog voltage output pin with a voltage proportional to the actual current through the TEC. ITEC's center voltage is 2V, corresponding to zero current through the TEC. $V_{ITEC} = \frac{I_{OUT}(A)}{7.5} + 2V$ , where $I_{OUT}$ is the actual output current of the controller, flowing out from TEC+ port and flowing in to TEC- pin.
15	<b>VTEC</b>	Analog output	TEC voltage indication. VTEC is an analog voltage output pin with a voltage proportional to the actual voltage across the TEC. It swings from 0V to 4V to indicate the output voltage being from -30V to 30V, so the center voltage is 2V. $V_{VTEC} = \frac{V_{TEC+} - V_{TEC-}}{15} + 2V$
16	<b>CTMO</b>	Analog output	The controller internal temperature indication output. It can be used for sensing the actual temperature of the controller, to avoid over-heating. 0V to 4V sets the internal temperature from -55°C to 125°C linearly. <b>For the controller with PID function:</b> When there is a new load and the PID coefficient needs to be re-identified, the voltage of the pin is 4V.
17, 18, 19, 20	<b>TEC+</b>	Analog power output	This pin is for connecting to the positive terminal of the TEC module, all 4 pins are internally connected for increasing the current capability.
21, 22, 23, 24	<b>TEC-</b>	Analog power output	This pin is for connecting to the negative terminal of the TEC module, all 4 pins are internally connected.
25, 26, 27, 28	<b>PGND</b>	Power ground	Power ground for connecting to the power supply 0V return node, all 4 pins are internally connected.
29, 30, 31, 32	<b>VPS</b>	Power input	Power supply voltage positive node. The normal operating voltage range is 5.5V to 9V, the maximum value is 9V. All 4 pins are internally connected.

\*There are two part numbers for selection, TEC9V6A and TEC9V6ASNCO. The former's pin 1 is 4VRS, and the latter's pin 1 is SNCO. It's recommended to use TEC9V6A.

Table 2. Electrical characteristics.

Parameter	Symbol	Conditions	Min.	Typ.	Max.	Units
<b>Reference Voltage Pulse Output Mode: 4VRS pin (Or Synchronization Output: SNCO pin), pin 1</b>						
Output Voltage Range	V <sub>4VRSOUT</sub>	T <sub>A</sub> = 25°C	4.0925	4.096	4.0995	V
Initial Error	V <sub>E</sub>	T <sub>A</sub> = 25°C	-0.05		0.05	%
Temperature Coefficient	T <sub>C</sub>			±3	±8	ppm/°C
Maximum Load Current	I <sub>4VRMAX</sub>	T <sub>A</sub> = 25°C	-20		+20	mA
Switch frequency	F <sub>4VRS</sub>		83	85	87	Hz
Output Voltage (Open circuit)	V <sub>SNCOOUT</sub>	Open circuit voltage = 0V ~ 4V PWM	0		4	V
Voltage Range (with load)	V <sub>SNCOOUT</sub>	Open circuit voltage = 0V ~ 4V PWM	0.1		3.9	V
Frequency	F <sub>SNCO</sub>	Open circuit voltage = 0V ~ 4V PWM		600		kHz
<b>Temperature Good Indication: TMGD pin, pin 2</b>						
Voltage Range (Open circuit)	V <sub>TMGDOUT</sub>	Open circuit voltage = 4V	0		4	V
Voltage Range (with load)	V <sub>TMGDOUT</sub>	Open circuit voltage = 4V	0		4	V
Maximum Sourcing Current	I <sub>TMGDSC</sub>	Open circuit voltage = 4V	1		15	mA
Maximum Sourcing Voltage	V <sub>TMGDSC</sub>	Open circuit voltage = 4V	3.7		4	V
Maximum Sinking Current	I <sub>TMGDsk</sub>	Open circuit voltage = 4V	3		20	mA
Maximum Sinking Voltage	V <sub>TMGDsk</sub>	Open circuit voltage = 4V	0		0.6	V
<b>Standby Shutdown Control: SBDN pin, pin 3</b>						
Input Current	I <sub>SBDNIN</sub>	V <sub>SBDN</sub> = 0V	0.1		0.3	μA
		V <sub>SBDN</sub> = 4V	4		6	
		V <sub>SBDN</sub> = 30V	30		50	
Input Voltage Range	V <sub>SBDNIN</sub>	Open circuit voltage = 5V	0		9	V
Shutdown Logic Low	V <sub>SBDNSDL</sub>	Open circuit voltage = 5V	0			V
Shutdown Logic High	V <sub>SBDNSDH</sub>	Open circuit voltage = 5V			0.7	V
Standby Logic Low	V <sub>SBDNSBL</sub>	Open circuit voltage = 5V	1.4			V
Standby Logic High	V <sub>SBDNSBH</sub>	Open circuit voltage = 5V			1.9	V
Operation Logic Low	V <sub>SBDNOPL</sub>	Open circuit voltage = 5V	2.0			V
Operation Logic High	V <sub>SBDNOPH</sub>	Open circuit voltage = 5V			5	V
<b>Reference Voltage Output: 4VR pin, pin 5</b>						
Output Voltage Range	V <sub>4VRROUT</sub>	T <sub>A</sub> = 25°C	4.0925	4.096	4.0995	V
Initial Error	V <sub>E</sub>	T <sub>A</sub> = 25°C		0.05		%
Temperature Coefficient	T <sub>C</sub>	T <sub>A</sub> = -40°C ~ 125°C		3	8	ppm/°C
Maximum Load Current	I <sub>4VRMAX</sub>	T <sub>A</sub> = 25°C	-20		+20	mA
Maximum Load Capacitance	C <sub>4VRMAX</sub>		0.1		1	μF



Parameter	Symbol	Conditions	Min.	Typ.	Max.	Units
<b>Temperature Set: TMS pin, pin 6</b>						
Input Impedance (See Figure 3 in Page 8 for input equivalent circuit)	Z <sub>TMSIN</sub>			5		MΩ
Input Voltage Range	V <sub>TMSIN</sub>		0		4	V
Open Circuit Voltage	V <sub>TMSOP</sub>			2		V
<b>Temperature Signal Input: IN+ pin, pin 7</b>						
Input Voltage Range	V <sub>IN+</sub>		0		4	V
<b>Thermistor Connection Port: RTH pin, pin 8</b>						
Input Voltage Range	V <sub>RTHIN</sub>		0		4	V
<b>Actual Target Object Temperature Indication: TMO pin, pin 9</b>						
Output Voltage Range	V <sub>TMOOUT</sub>	R <sub>LOAD</sub> = 10kΩ to 2V -40°C ≤ T <sub>A</sub> ≤ +125°C	0		4	V
Output Current	I <sub>TMOOUT</sub>	V <sub>SS</sub> = 0V T <sub>A</sub> = 25°C	-12		12	mA
<b>Compensation Input: CMIN pin, pin 10</b>						
Input Voltage Range	V <sub>CMIN</sub>	R <sub>LOAD</sub> = 10kΩ to 2V -40°C ≤ T <sub>A</sub> ≤ +125°C	0		4	V
Input Current	I <sub>CMIN</sub>	-40°C ≤ T <sub>A</sub> ≤ +125°C		90	200	pA
<b>Compensation Output: IDR pin, pin 11</b>						
Output Voltage Range	V <sub>IDROUT</sub>	R <sub>LOAD</sub> = 10kΩ to 2V -40°C ≤ T <sub>A</sub> ≤ +125°C	0		4	V
<b>TEC Current Limit: ILM pin, pin 12</b>						
Input Impedance	Z <sub>ILM</sub>			21		kΩ
Input Voltage Range	V <sub>ILMIN</sub>		0		4	V
<b>TEC Voltage Limit: VLM pin, pin 13</b>						
Input Impedance (See Figure 4 in Page 8 for input equivalent circuit)	Z <sub>VLM</sub>			10		kΩ
Input Voltage Range	V <sub>VLMIN</sub>		0		4	V
<b>TEC Current Indication: ITEC pin, pin 14</b>						
<b>TEC Voltage Indication: VTEC pin, pin 15</b>						
<b>Controller Temperature Indication: CTMO pin, pin 16</b>						
Output Voltage Range	V <sub>CTMO</sub>	T <sub>A</sub> = 25°C	0		4	V
Maximum Load Current	I <sub>CTMOOUT</sub>	T <sub>A</sub> = 25°C	-12		12	mA
<b>TEC+/TEC- pin, pin 17~20/pin 21~24</b>						
Maximum Output Current	I <sub>MAXTEC+</sub>    I <sub>MAXTEC-</sub>	V <sub>VPS</sub> = 5.5V~9V T <sub>A</sub> = 25°C	0		6	A
Maximum Output Voltage	V <sub>OUTMAX</sub>	V <sub>VPS</sub> = 9V	0		7.2	V

Parameter	Symbol	Conditions	Min.	Typ.	Max.	Units
<b>Power Supply Input: VPS pin, pin 29~32</b>						
Input Voltage Range	$V_{VPS}$		5.5		9	V
Input Current	$I_{VPS}$	Operation mode	0.05		16	A
	$I_{VPSSB}$	Standby mode	5		20	mA
	$I_{VPSSD}$	Shutdown mode			50	$\mu$ A
<b>Temperature Stability</b>						
Temperature Error Voltage	$V_{TMO}-V_{TMS}$		-0.47	0.02	0.47	mV
Efficiency	$\eta$	$V_{VPS}=9V$ $ V_{TEC+}-V_{TEC-} =14V$ $ I_{TEC+}-I_{TEC-} =6A$		$\geq 92$		%
Case Operating Temperature Range	$T_{CS}$		-40		110	$^{\circ}C$
Ambient Operating Temperature Range	$T_A$		-40		65	$^{\circ}C$
Storage Temp. Range	$T_{STG}$		-40		125	$^{\circ}C$
Controller Case Thermal Resistance	$R_{TH}$			9		$^{\circ}C/W$

This TEC controller can only drive the TECs having  $>1\Omega$  impedance, which equals  $V_{MAX} / I_{MAX}$ .

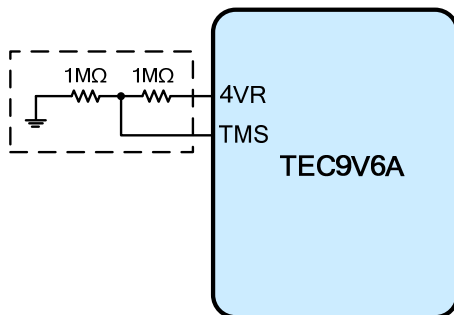

Figure 3. TMS Input Equivalent Circuit

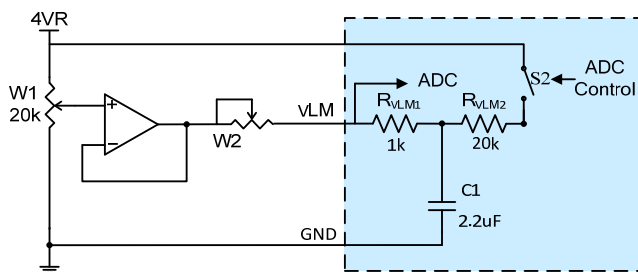

Figure 4. VLM Input Equivalent Circuit

The switch S2 is closed @ heating, and open @ cooling

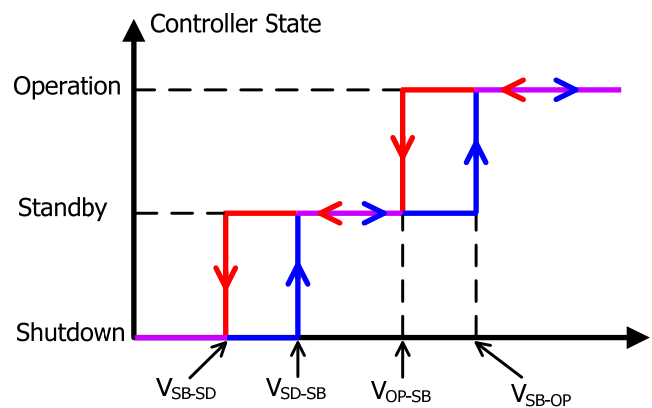

Figure 5. Controller States

$V_{SB-SD}$ : Going down logic low from standby to shutdown

$V_{SD-SB}$ : Going up logic high from shutdown to standby

$V_{OP-SB}$ : Going down logic low from operation to standby

$V_{SB-OP}$ : Going up logic high from standby to operation



### BLOCK DIAGRAM

The block diagram of the controller is shown in Figure 6.

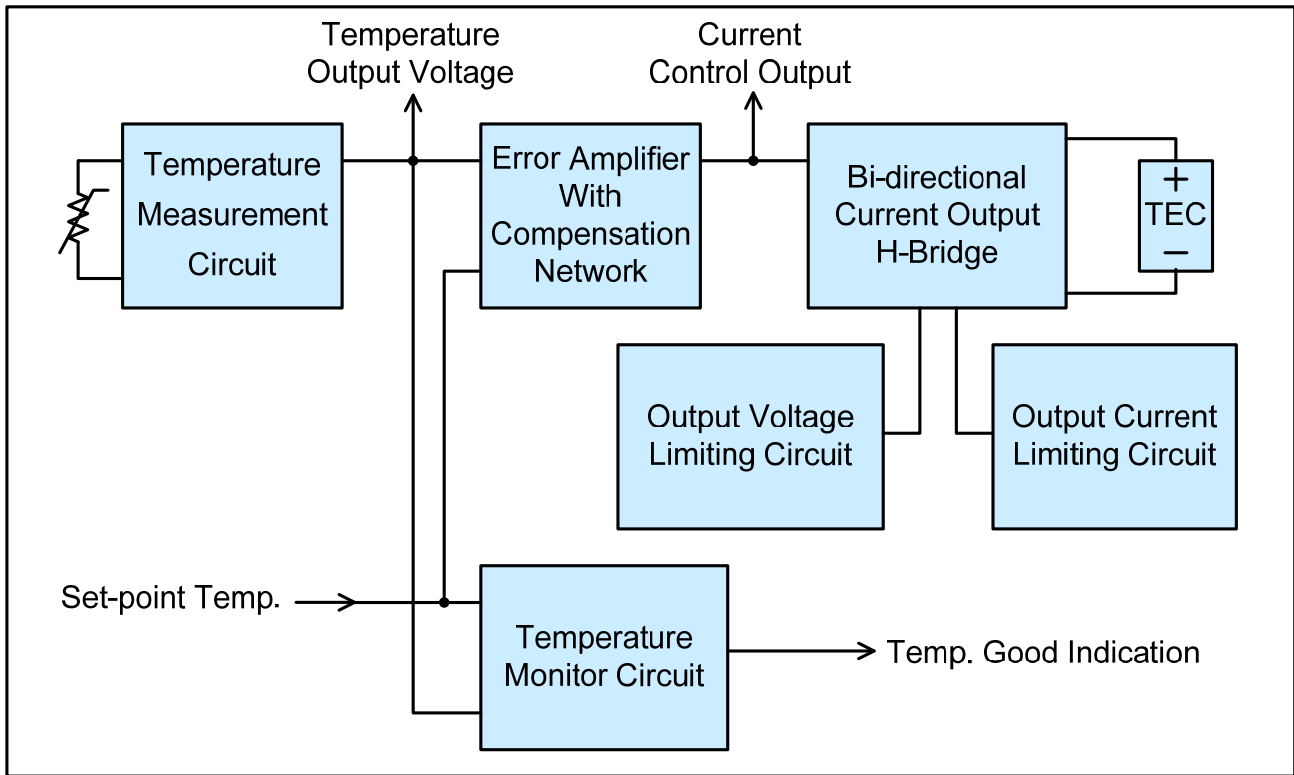

Figure 6. TEC Controller Block Diagram

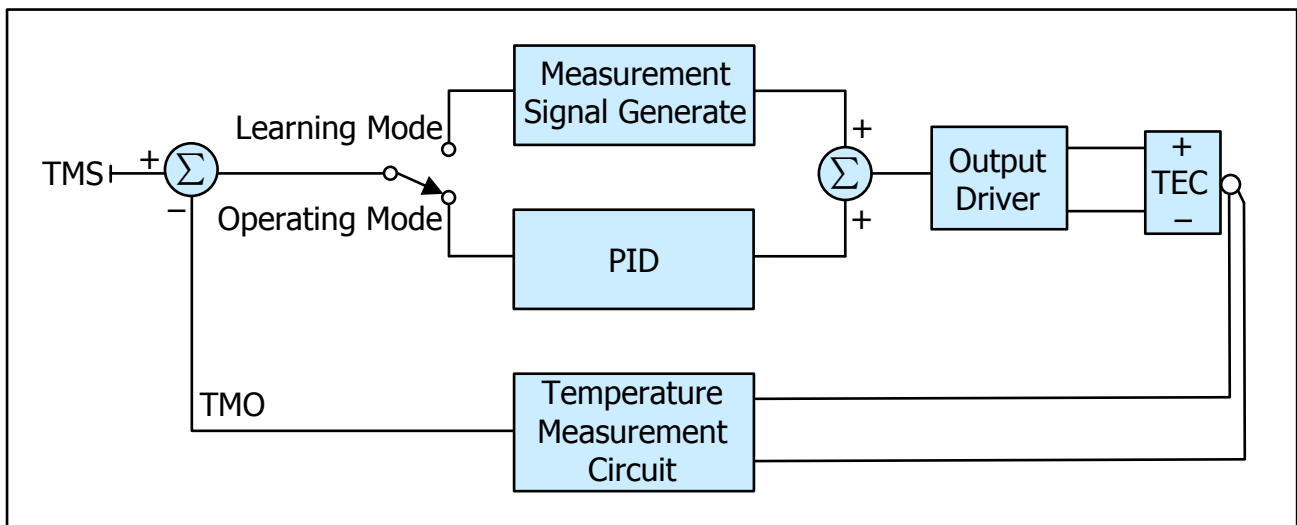

Figure 7. Auto PID System Block Diagram





APPLICATIONS

TEC controller connections are shown in Figure 8.

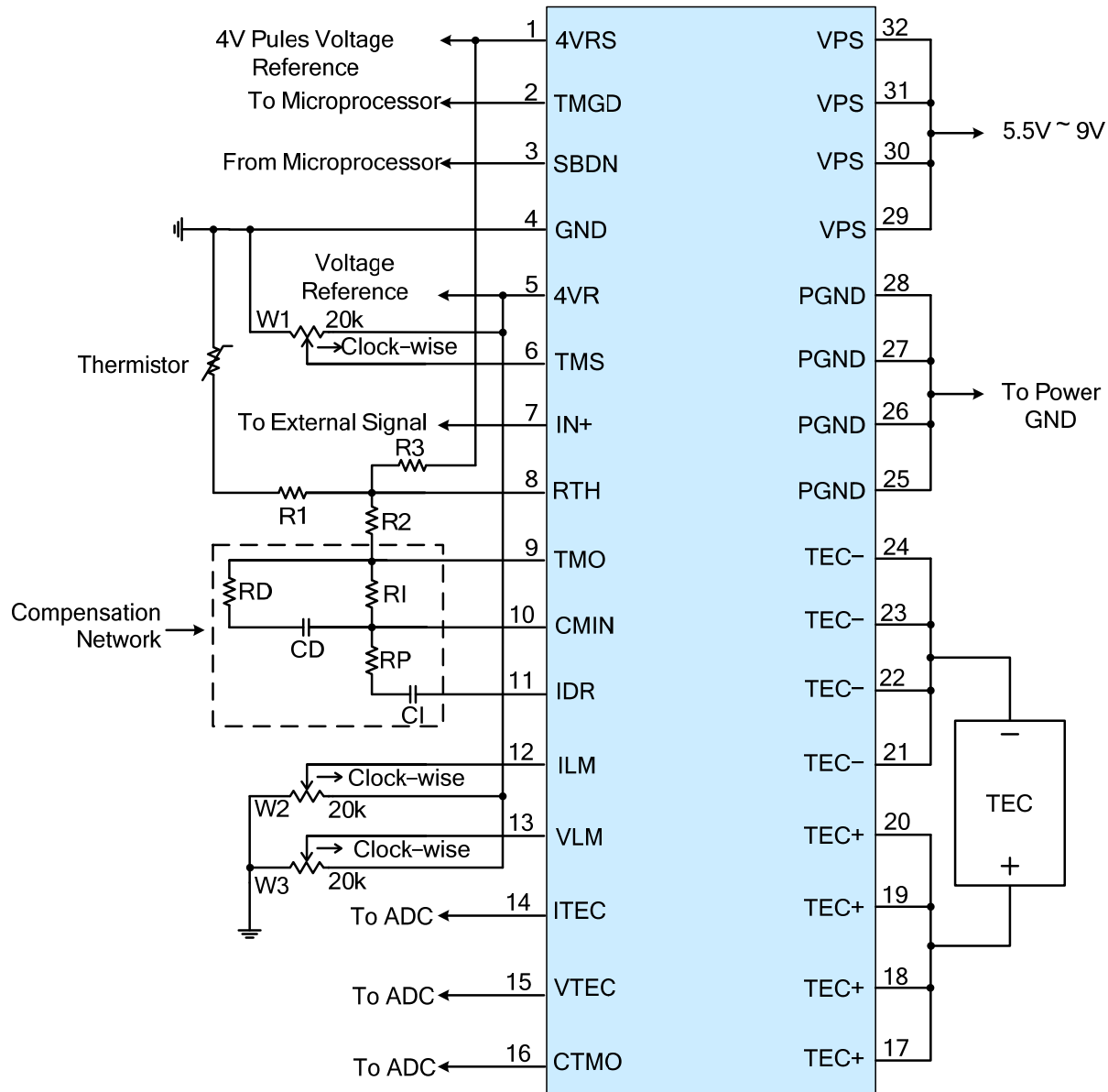

Figure 8.1. TEC Controller Connection

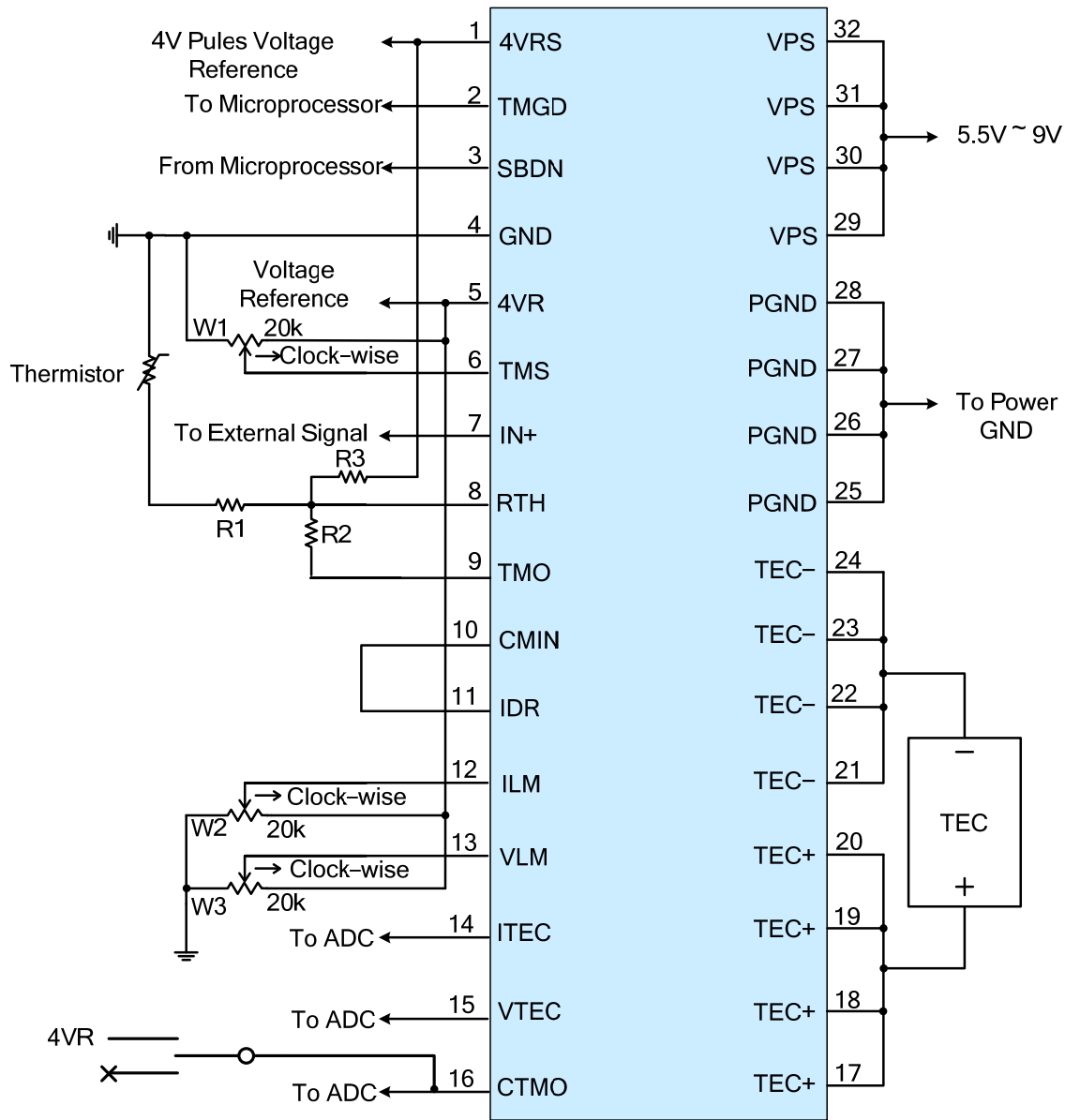

Figure 8.2. Connection for TEC9V6ADAPID & TEC9V6ASAPID



**SBDN**

Table 3. External Detector Selection.

No.	Input	Voltage	External Detector
1	SBDN	0V ~ 0.5V	SD
2	SBDN	1.5V ~ 1.9V	SB
3	SBDN	2V ~ 2.3V	Temperature sensor
4	SBDN	2.4V ~ 2.6V	RTD/RTH
5	SBDN	3.1V ~ 4.0V	RTH (pulse mode)

Note: Do not set the SBDN pin to 2.7V to 3V, otherwise the controller will lose control.

**For the controller with PID function:**

No.	Input	Voltage	External Detector	PID
1	SBDN	0V ~ 0.5V	SD	N/A
2	SBDN	1.5V ~ 1.7V	SB	N/A
3	SBDN	1.9V ~ 2.1V	For RTD Sensor or IC-Positive Temperature Coefficient	Analog PID
4	SBDN	2.3V ~ 2.5V	RTH Sample Hold Mode	
5	SBDN	2.7V ~ 2.9V	RTH CW mode or IC- Negative Temperature Coefficient	
6	SBDN	3.1V ~ 3.3V	For RTD Sensor or IC-Positive Temperature Coefficient	Auto PID
7	SBDN	3.5V ~ 3.7V	RTH Sample Hold Mode	
8	SBDN	3.8V ~ 4.0V	RTH CW mode or IC- Negative Temperature Coefficient	

**Temperature Sensor Selections**

There are usually three temperature sensors, thermistor, RTD (Resistance Temperature Detector), and IC (Integrated Circuit) temperature sensors.

1. Thermistor

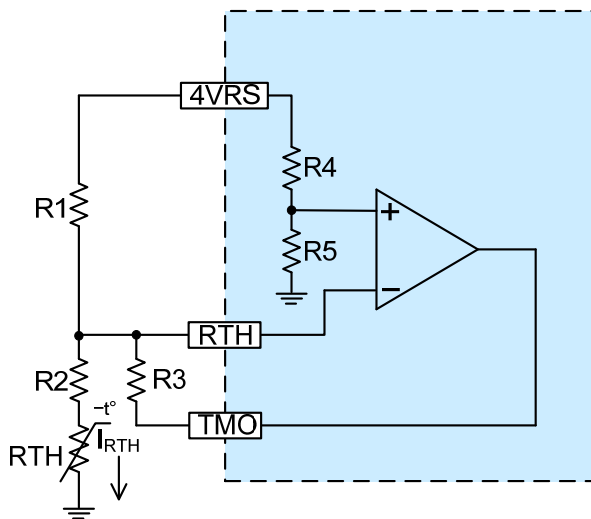
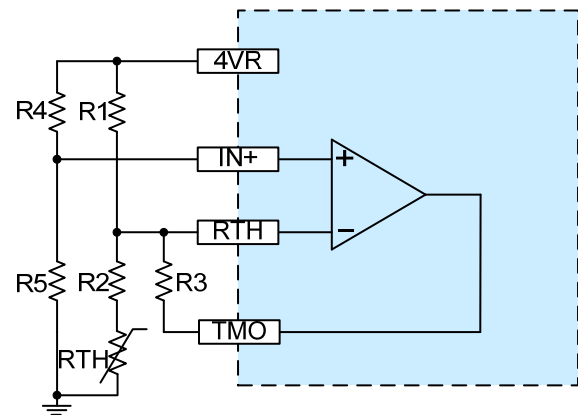

Figure 9.1. RTH (Pulse Mode)



Note: R4=R5

Figure 9.2. RTH

To achieve the required  $V_{TMO}$  outputs at the three different setting point temperatures in the Temperature Network, use the equation:

$$R1 = R_{MID} + \frac{R_{MID} \times (R_{LOW} + R_{HIGH}) - 2 \times R_{HIGH} \times R_{LOW}}{R_{HIGH} + R_{LOW} - 2 \times R_{MID}} \quad (1)$$

$$R2 = R1 - R_{MID} \quad (2)$$

$$R3 = \frac{R1 \times (R1 + R_{LOW} - R_{MID})}{R_{LOW} - R_{MID}} \quad (3)$$

For example, setting the high set-point temperature at 35°C and the low set-point temperature at 15°C results in a middle set-point temperature  $(35 + 15)/2 = 25^\circ\text{C}$ . Use the R-T table of a thermistor.

$$R_{HIGH} = 6.9\text{k}\Omega$$

$$R_{MID} = 10\text{k}\Omega$$

$$R_{LOW} = 14.8\text{k}\Omega$$

Note that Equation 1 to Equation 3 result in

$$R1 = 17.5\text{k}\Omega$$

$$R2 = 7.5\text{k}\Omega$$

$$R3 = 81.3\text{k}\Omega$$

In order to reduce the injection current to the thermistor to reduce the errors caused by the self-heating effect, the injection current is provided in pulse mode, reducing the current by 10 times as opposed to a continuous current.

It's recommended to connect R1 to 4VR, and the controller will measure temperature at intervals that will reduce the error caused by the RTH self-heating. At the same time, the SBDN pin should be between 3.1V and 4V. See Table 3.

We can also connect R1 to 4VR, but it may lead to some errors caused by RTH self-heating. At the same time, SBDN pin should be between 2.4V and 2.6V. See Table 3.

## 2. RTD

RTD is short for resistance temperature detector, which features high accuracy and low drift. It usually generates heat when the current flows through the RTD, which is called self-heating effect. Moreover, RTD has an approximate linear resistance-temperature relationship.

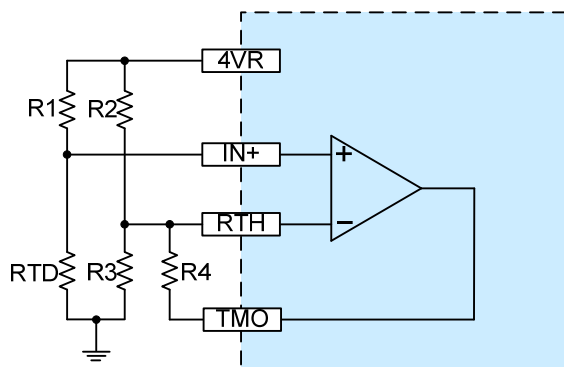

Figure 10. RTD

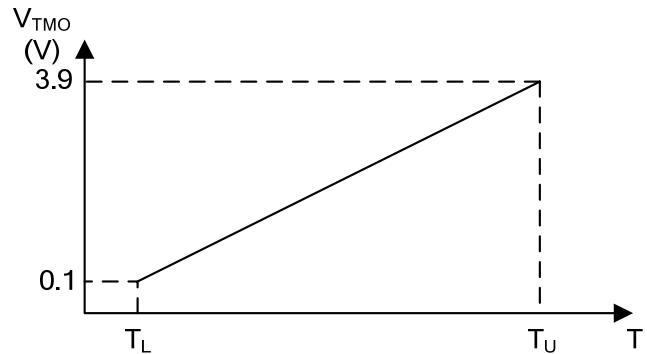

Figure 11. Linear Relationship between  $V_{TMO}$  and Temperature

$$R_{TD} = R_0 \times (1 + 0.00385T)$$

e.g.  $R_0 = 1\text{k}\Omega$

$$\text{When } T = 10^\circ\text{C}, R_{TD}(10) = 1.0385\text{k}\Omega$$

$$\text{When } T = 40^\circ\text{C}, R_{TD}(40) = 1.154\text{k}\Omega$$

Choose R1

$$\text{A. } P_{RTD} \leq 1\text{mW}, R_{TD} = 1000\Omega$$

$$P_{RTD} = (I_{RTD})^2 \times 1000\Omega = 0.001\text{W}$$

$$I_{RTD} = 1\text{mA} = \frac{4\text{VR}}{R1 + R_{TD}} = \frac{4}{R1 + 1\text{k}} \implies R1 = 3\text{k}\Omega$$

$$\text{B. } P_{RTD} \leq 1\text{mW}, R_{TD} = 100\Omega$$

$$P_{RTD} = (I_{RTD})^2 \times 100\Omega = 0.001\text{W}$$

$$I_{RTD} = 3.16\text{mA} = \frac{4\text{VR}}{R1 + R_{TD}} = \frac{4}{R1 + 0.1\text{k}} \implies$$

$$R1 = 1.15\text{k}\Omega$$

$$V_{TMO} = \frac{4 \times R_{TD}}{R1 + R_{TD}} \times \left[ 1 + \frac{R4 \times (R2 + R3)}{R2 \times R3} \right] - \frac{4 \times R4}{R2}$$

$$\text{I. When } T = 10^\circ\text{C}, R1 = 3\text{k}\Omega, R_{TD}(T_L) = 1.0385\text{k}\Omega,$$

$$0.93 = \frac{R4 \times (2.97R3 - 1.03R2)}{R2 \times R3}$$

$$\text{When } T = 40^\circ\text{C}, R1 = 3\text{k}\Omega, R_{TD}(T_U) = 1.154\text{k}\Omega,$$

$$2.79 = \frac{R4 \times (1.11R2 - 2.89R3)}{R2 \times R3}$$

$$\text{II. When } T = 10^\circ\text{C}, R1 = 1.15\text{k}\Omega, R_{TD}(T_L) = 1.0385\text{k}\Omega,$$

$$1.8 = \frac{R4 \times (2.1R3 - 1.9R2)}{R2 \times R3}$$

$$\text{When } T = 40^\circ\text{C}, R1 = 1.15\text{k}\Omega, R_{TD}(T_U) = 1.154\text{k}\Omega,$$

$$1.9 = \frac{2 \times R4 \times (R2 - R3)}{R2 \times R3}$$

To achieve the required  $V_{TMO}$  outputs at the three different setting point temperatures in the Temperature Network, use the equation:

When  $T = \text{LOW}$ ,  $RTD = RTD_L$ ,  $TMO = 0.1V$ ,  $V_1 = V_{1L}$

When  $T = \text{HIGH}$ ,  $RTD = RTD_H$ ,  $TMO = 4.0V$ ,  $V_1 = V_{1H}$

$$\Delta TMO = 4V - 0.1V = 3.9V$$

$$\Delta V_1 = V_{1H} - V_{1L}$$

$$G = \frac{\Delta TMO}{\Delta V_1} = 1 + \frac{R_4 \times (R_2 + R_3)}{R_2 \times R_3}$$

$$RTD = R_0 \times (1 + 0.00385T)$$

e.g.  $R_0 = 1k\Omega$

$$V_1 = 4.096V \times \frac{RTD}{R_1 + RTD}$$

$$V_{1L} = 0.5V$$

$$R_1 = RTD_L \times \frac{4.096V}{V_{1L}} - RTD_L$$

$$R_2 = R_1, R_3 = RTD_L$$

$$R_4 = (G - 1) \times \frac{R_2 \times R_3}{R_2 + R_3}$$

For example, setting the high set-point temperature at  $60^\circ\text{C}$  and the low set-point temperature at  $0^\circ\text{C}$ . Use  $RTD = R_0 \times (1 + 0.00385T)$ , (e.g.  $R_0 = 1k\Omega$ ).

$$RTD_L = RTD(0^\circ\text{C}) = 1.0k\Omega$$

$$RTD_H = RTD(60^\circ\text{C}) = 1.231k\Omega$$

$$R_1 = 7.192k\Omega$$

$$R_2 = R_1 = 7.192k\Omega$$

$$R_3 = RTD_L = 1.0k\Omega$$

$$R_4 = 32.308k\Omega$$

### 3. IC

#### (1). Positive Coefficient

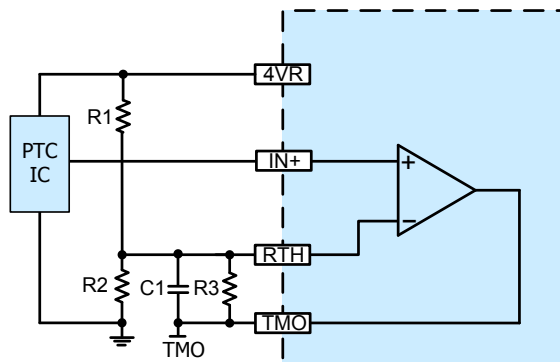

Figure 12.1. PTC IC temperature sensor

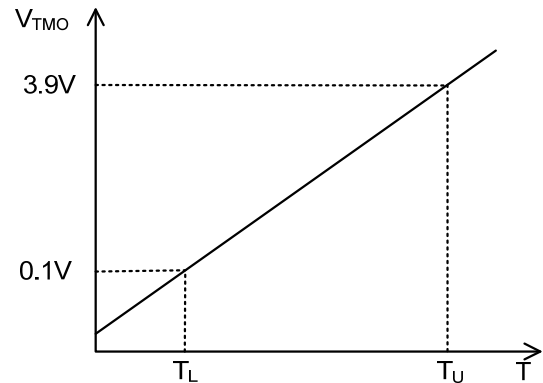

Figure 12.2. Objective

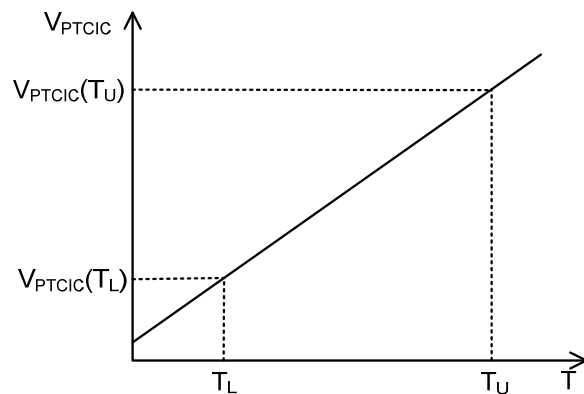

Figure 12.3. Temperature vs.  $V_{PTCIC}$

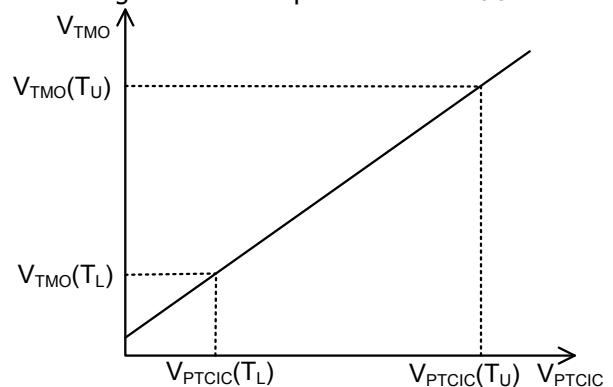

Figure 12.4.  $V_{PTCIC}$  vs.  $V_{TMO}$

$$V_{TMO}(T_L) = 0.1V, V_{TMO}(T_U) = 3.9V$$

$$G = \frac{\Delta V_{TMO}}{\Delta V_{PTCIC}} = \frac{V_{TMO}(T_U) - V_{TMO}(T_L)}{V_{PTCIC}(T_U) - V_{PTCIC}(T_L)}$$

$$G = \frac{R_3}{R_1/R_2} + 1$$

$$V_{PTCIC}(T_M) = \frac{V_{PTCIC}(T_U) + V_{PTCIC}(T_L)}{2}$$



$$V_{PTCIC} = V_{PTCIC}(T_M), V_{TMO} = \frac{3.9V + 0.1V}{2} = 2V$$

$$\frac{V_{PTCIC}(T_M)}{R2} = \frac{2V - V_{PTCIC}(T_M)}{R3} + \frac{4V - V_{PTCIC}(T_M)}{R1}$$

R3=20kΩ

$$R2 = \frac{R3}{[4V - V_{PTCIC}(T_M)] \times G - 2}$$

$$R1 = \frac{R2 \times R3}{R2 \times (G - 1) - R3}$$

2. Negative Coefficient

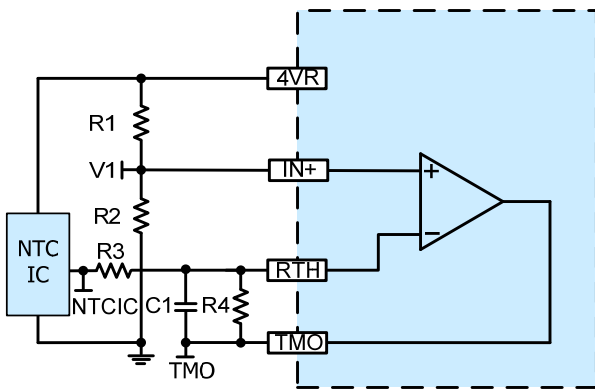

Figure 13.1. NTC IC temperature sensor

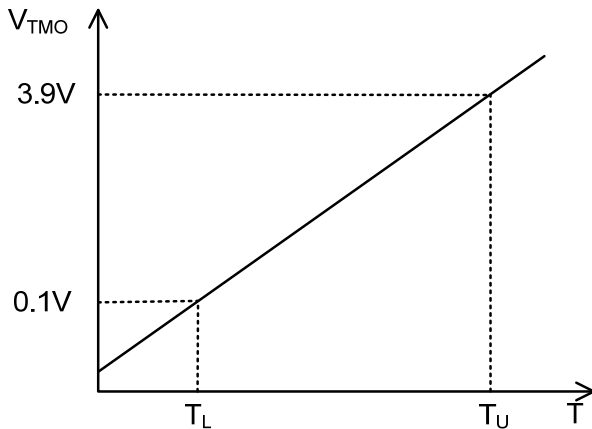

Figure 13.2. Objective

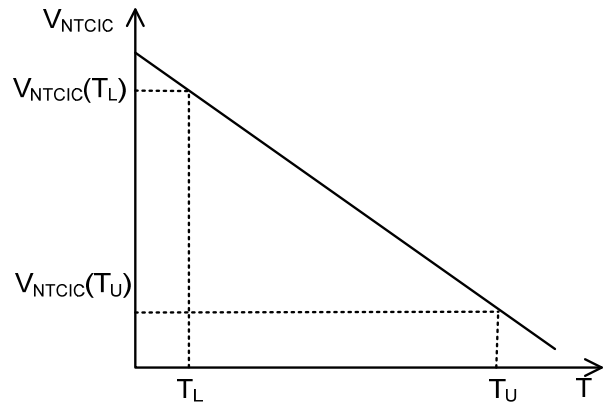

Figure13.3. Temperature vs. V<sub>NTCIC</sub>

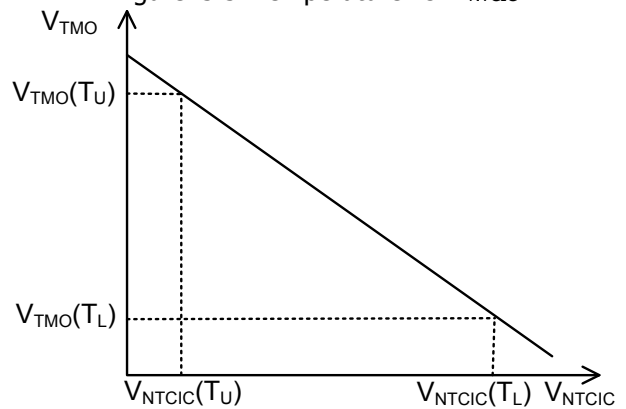

Figure 13.4. V<sub>PTCIC</sub> vs. V<sub>TMO</sub>

$$V_{TMO}(T_L) = 0.1V, V_{TMO}(T_U) = 3.9V$$

$$G = \frac{\Delta V_{TMO}}{\Delta V_{NTCIC}} = \frac{V_{TMO}(T_U) - V_{TMO}(T_L)}{V_{NTCIC}(T_U) - V_{NTCIC}(T_L)}$$

$$G = \frac{R4}{R3}$$

R4 = 20kΩ ~ 200kΩ

$$R3 = \frac{R4}{G}$$

$$V_{NTCIC}(T_M) = \frac{V_{NTCIC}(T_U) + V_{NTCIC}(T_L)}{2}$$

$$\frac{[2V - V_{NTCIC}(T_M)] \times R3}{R3 + R4} + V_{NTCIC}(T_M) = \frac{4V \times R2}{R1 + R2}$$

R2=10k

$$R1 = \frac{40 \times (1 + G)}{2 - V_{NTCIC}(T_M)} - 10$$

$$\frac{1}{2\pi \times (R3//R4) \times C} = 200\text{Hz}$$

$$C = \frac{1}{2\pi \times (R3//R4) \times 200\text{Hz}} = \frac{1 + G}{400\pi \times R4}$$

$$\text{Maximum sourcing current: } \frac{V_{\text{NTCIC}}(T_L) - V1}{R3} \leq I_{\text{SOURCEMAX}}$$

$$\text{Maximum sinking current: } \frac{V1 - V_{\text{NTCIC}}(T_L)}{R3} \leq I_{\text{SOURCEMAX}}$$

### SBDN

SBDN is suggested to be pulled up to VPS with a 10µA current and contains a 1.50V logic threshold. Drive this pin to a logic-high to enable the TEC9V6A. Drive to a logic-low to disable the TEC controller and enter micro-power shutdown mode.

### ITEC and ILM

When the voltage of the ITEC is  $V_{\text{ITEC}} = 2\text{V}$ , the current of the TEC Controller  $I_{\text{TEC}} = 0\text{A}$ . When  $V_{\text{ITEC}} = 0\text{V}$ ,  $I_{\text{TEC}}$  has the maximum reverse current,  $-6\text{A}$ . When  $V_{\text{ITEC}} = 4\text{V}$ ,  $I_{\text{TEC}}$  has the maximum forward current,  $6\text{A}$ .

TEC controller is working on the cooling region, when it has forward current. On the opposite, it works on the heating region when reversing the current, as shown in Figure 14.

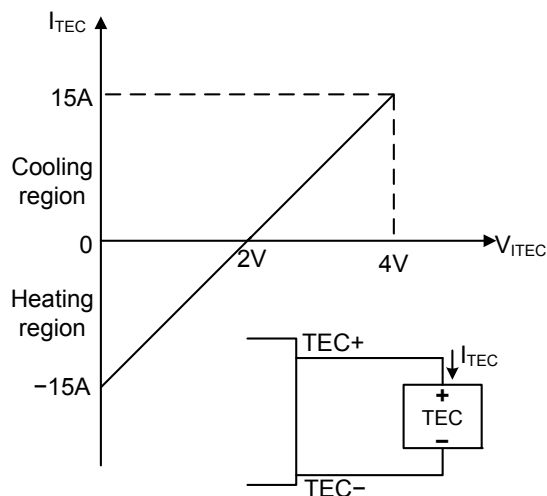

Figure 14.  $V_{\text{ITEC}}$  vs.  $I_{\text{TEC}}$

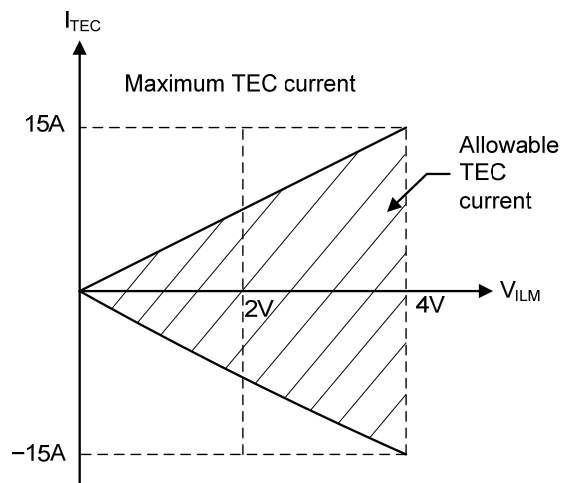

Figure 15.  $V_{\text{ILM}}$  vs.  $I_{\text{TEC}}$

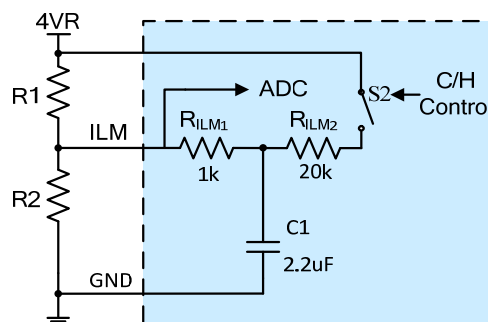

Figure 16. ILM vs. Cooling and Heating Control

The switch S1 is closed @ heating, and open @ cooling

Calculate the maximum current in cooling and heating region according to Figure 16.

#### 1. Cooling region

$I_{\text{TEC}} \geq 0\text{A}$ ,  $V_{\text{ILM}} \geq 2\text{V}$ , Cooling region => S1 = Open;

Maximum cooling current:

$$I_{\text{TEC}} \leq \frac{V_{\text{ILM}}}{4\text{V}} \times 15\text{A} = \frac{R2}{R1 + R2} \times 15\text{A}$$

#### 2. Heating region

$I_{\text{TEC}} < 0\text{A}$ ,  $V_{\text{ILM}} < 2\text{V}$ , Heating region => S1 = Close;

Maximum heating current:

$$|I_{\text{TEC}}|_{\text{MAX}} \leq \frac{V_{\text{ILM}}}{4\text{V}} \times 15\text{A} = \frac{R2//R_{\text{ILM}}}{R1 + R2//R_{\text{ILM}}} \times 15\text{A}$$

3. After deciding the heating current shrinking ratio, we can determine the value for R1 & R2.

Calculate R1 & R2 ratio

$$I_{COOLMAX} = \frac{R1}{R1 + R2} \times 15A \quad \text{-----(1)}$$

Calculate R1 & R2 value by deciding the heating current shrinking ratio:

KHC = maximum heating current / maximum cooling current

$$= \frac{I_{ITEC-(TH-MAX)}}{I_{ITEC-(CL-MAX)}} \quad \text{-----(2)}$$

$$= \frac{\frac{R2 // R_{ILM}}{R1 + R2 // R_{ILM}}}{\frac{R2}{R1 + R2}}$$

$$= \frac{200 \times (R1 + R2)}{R1 \times R2 + 200 \times (R1 + R2)}$$

### VTEC and VLM

VTEC = V<sub>TEC+</sub> - V<sub>TEC-</sub>, as shown in Figure 18.

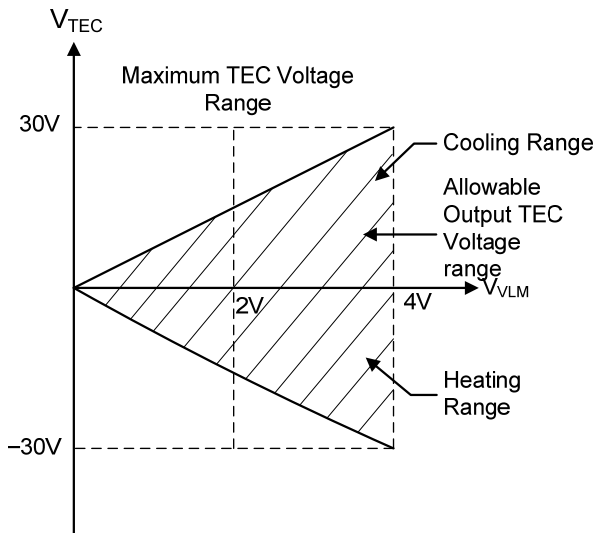

Figure 17. V<sub>TEC</sub> vs. V<sub>VLM</sub>

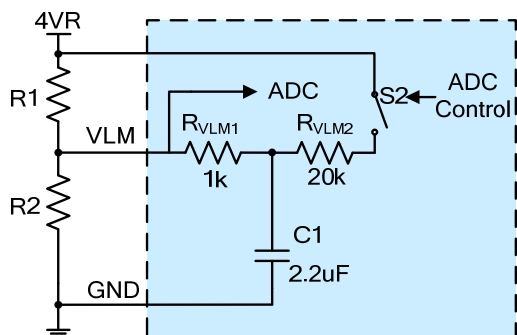

Figure 18. VLM vs. Cooling and Heating Control

The switch S2 is closed @ heating, and open @ cooling

### TMGD

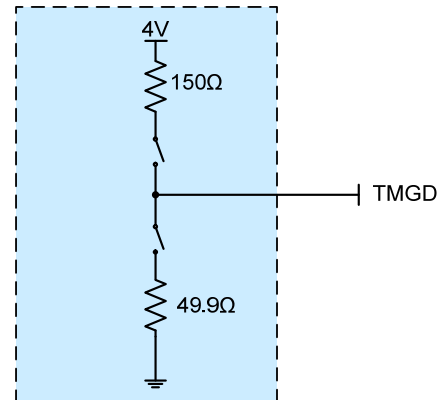

Figure 19. Output Equivalent Circuit for TMGD Pin

The TMGD pin outputs the maximum source current and sink current of 20mA. The output current will cause voltage drop, see Figure 19.

### VLM and ILM

If you want to use this TEC controller for other applications not discussed here, such as with wave locker controllers, consult with us. The same for other customizations, such as setting the ILM and VLM by using voltage source swings above 4V and/or VPS.

An external voltage connects the ILM pin through a resistor. This voltage can be used to adjust the voltage range of cooling or heating, and advice is 1.5V. The resistor can be used to adjust the difference of cooling and heating, and advice is 10kΩ. See Figure 20.

For example, the voltage midpoint of the ILM pin (V<sub>m</sub>) is 2V. Adjust the external voltage, and make the voltage range 1V, but it is only with the center of 2V (V<sub>m</sub>). If you adjust the resistor W2, you can move the limit of the cooling to be greater than the limit of the heating. It is shown in Figure 21 and Figure 22.

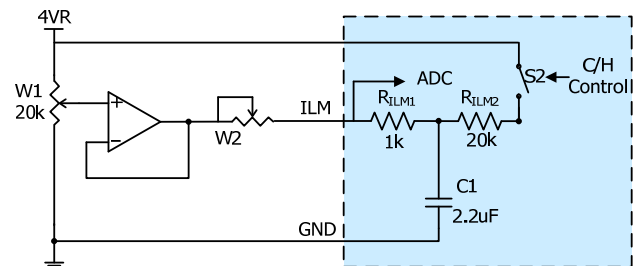

Figure 20. ILM vs. Cooling and Heating Control



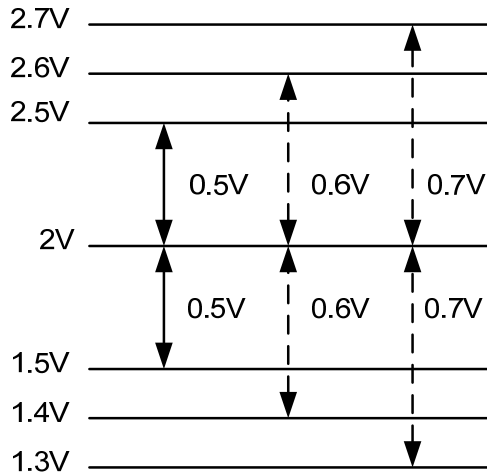

Figure 21. Adjust the External Voltage

We can tell the VLM or ILM voltage in cooling control or heating control through the waveforms on the VLM or ILM pin, see Figure 23 and Figure 24. The duty cycle in Figure 23 is 99% and 1% in Figure 25. We can also measure both voltages by a multimeter. When the controller is in the Standby State, the voltage measured by the multimeter is the VLM or ILM voltage in cooling control. When the controller is in Operation State, the voltage measured by the multimeter is the VLM or ILM voltage in heating control.

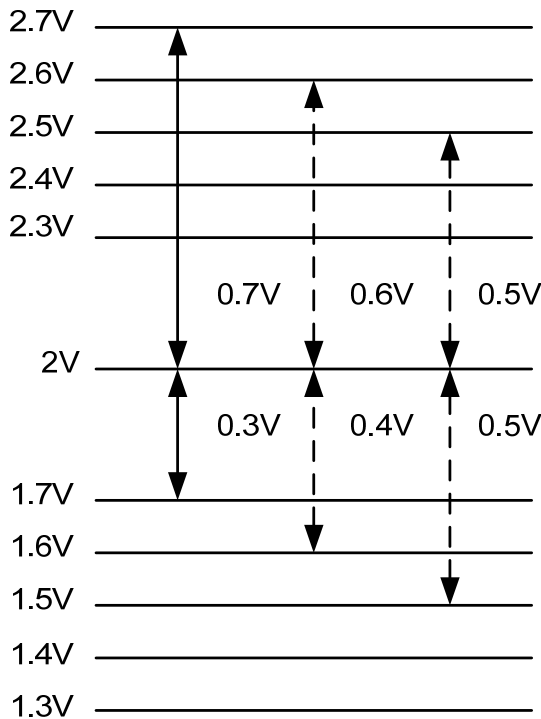

Figure 22. Adjust the Resistor

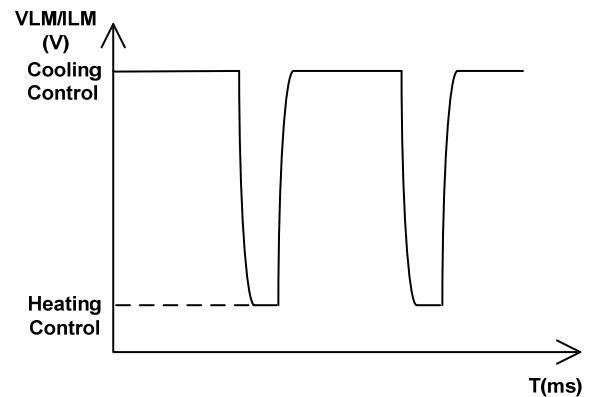

Figure 23. The Waveform on the VLM or ILM Pin @ SB State

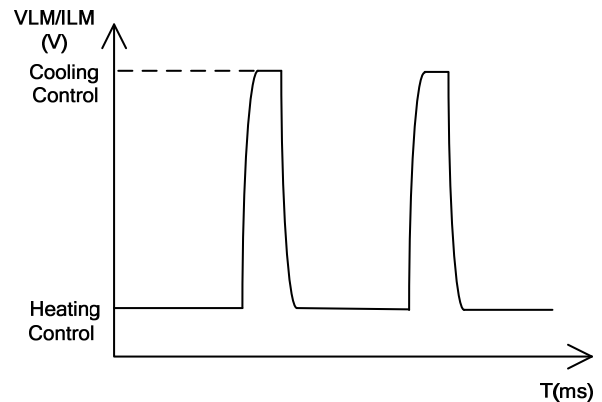

Figure 24. The Waveform on the VLM or ILM Pin @ Operation State

Temperature-Network

TEC9V6A comes with a customized internal compensational network for which the component values are specified by the customer. See Figure 8.

TEC9V6A comes with a customized Temperature network. See Figure 6 and Figure 8.



TYPICAL CHARACTERISTICS

Table 4. Measurement Data of Rth vs. Temperature

Temp. (°C)	Rth (kΩ)	TMO (V)	Ideal Linear (V)	Error (V)
15	15.7049	0.05	0.1	-0.05
16	14.9944	0.24	0.3	-0.06
17	14.3198	0.43	0.49	-0.06
18	13.6792	0.63	0.69	-0.06
19	13.0705	0.82	0.88	-0.06
20	12.4922	1.02	1.08	-0.06
21	11.9425	1.22	1.27	-0.05
22	11.4198	1.42	1.47	-0.05
23	10.9227	1.62	1.66	-0.04
24	10.4499	1.82	1.86	-0.04
25	10	2.03	2.05	-0.02

Temp. (°C)	Rth (kΩ)	TMO (V)	Ideal Linear (V)	Error
26	9.5718	2.23	2.25	-0.02
27	9.1642	2.44	2.44	0
28	8.776	2.64	2.64	0
29	8.4063	2.85	2.83	0.02
30	8.0541	3.05	3.03	0.02
31	7.7184	3.25	3.22	0.03
32	7.3985	3.46	3.42	0.04
33	7.0935	3.66	3.61	0.05
34	7.0935	3.86	3.81	0.05
35	6.5251	4.06	4.00	0.06

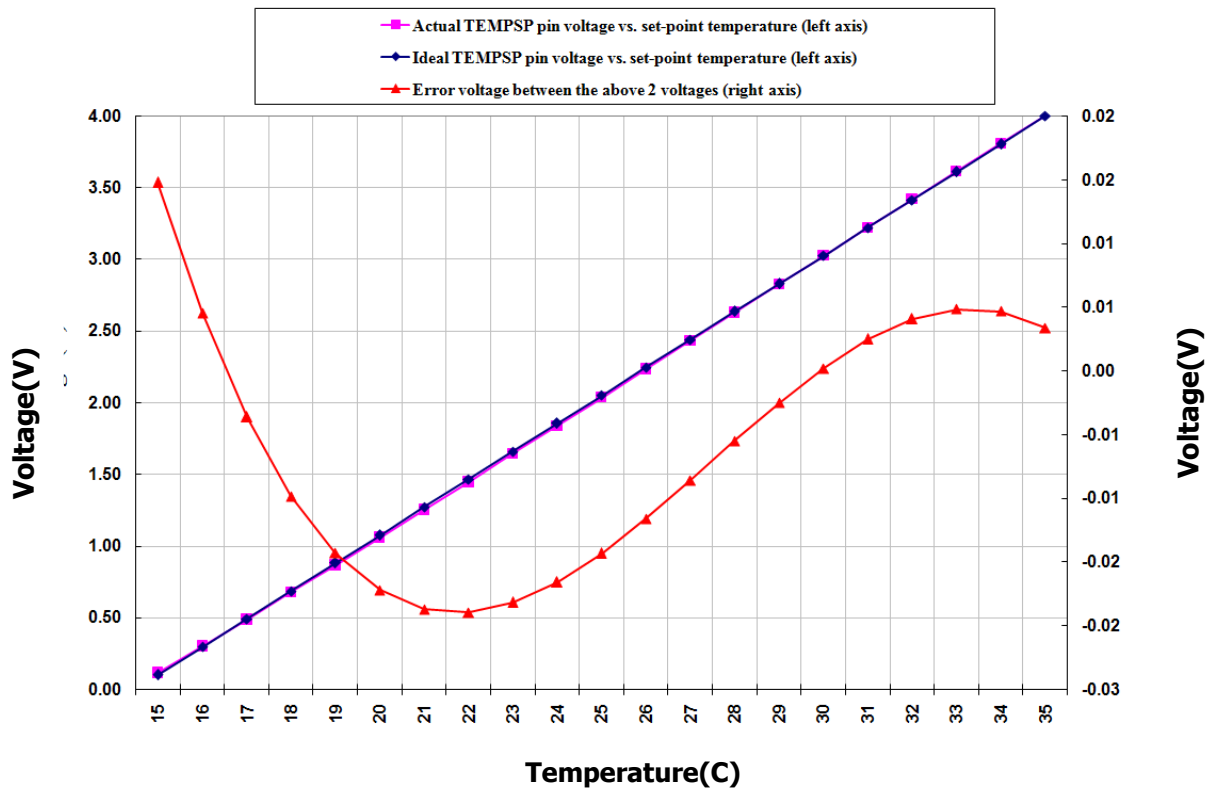

Figure 25. TMO Pin Voltage vs. Set-point Temperature



### HEAT DISSIPATION

The heating elements of the TEC9V6A TEC controller are on the top layer next to the shell, so the heat sink needs to be installed on the top of the controller shell. When the output current of

the controller is  $<8A$ , no heat sink is required. When the output current is  $>8A$ , a heat sink is needed to ensure the internal temperature of the controller is  $<85^{\circ}C$ .

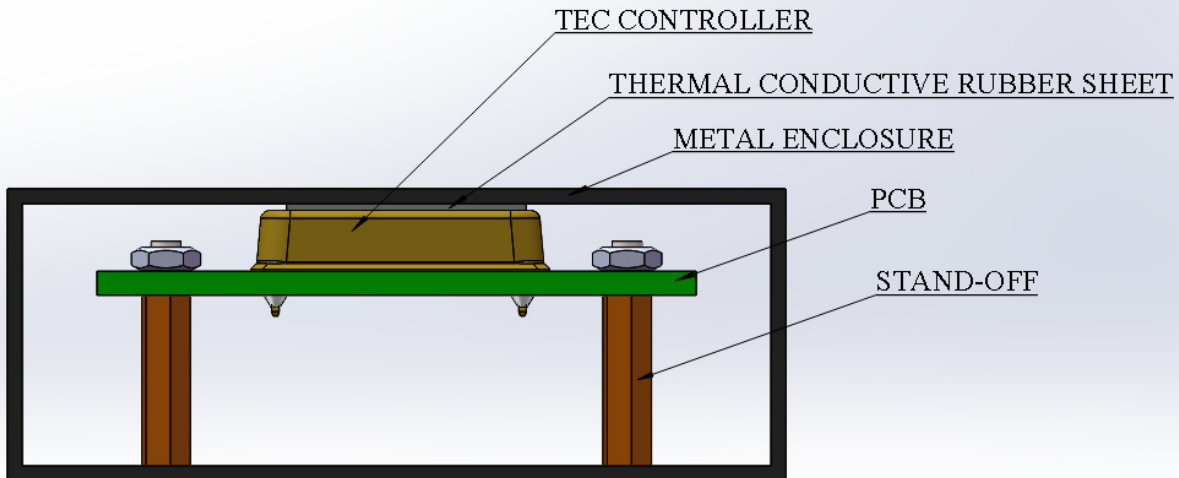

Figure 26. Transferring Heat with Metal Enclosure

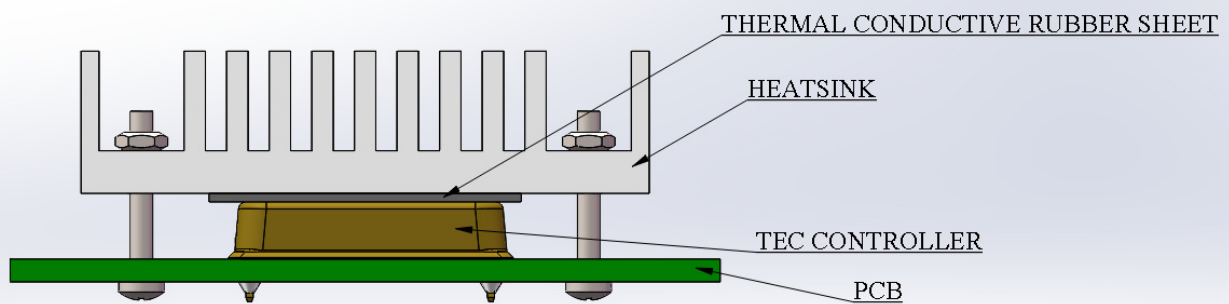

Figure 27. Transferring Heat with Heat Sink

### MECHANICAL DIMENSIONS

The controller comes in 2 packages: through-hole mount and surface mount. The former is often called DIP (Dual Inline package) or D (short for DIP) package and has a part number: TEC9V6AD, and the latter is often called SMT (Surface Mount Technology) or SMD (Surface Mount Device) package and has a part number: TEC9V6AS. Dimensions of this controller is shown in Figure 28 and Figure 29.

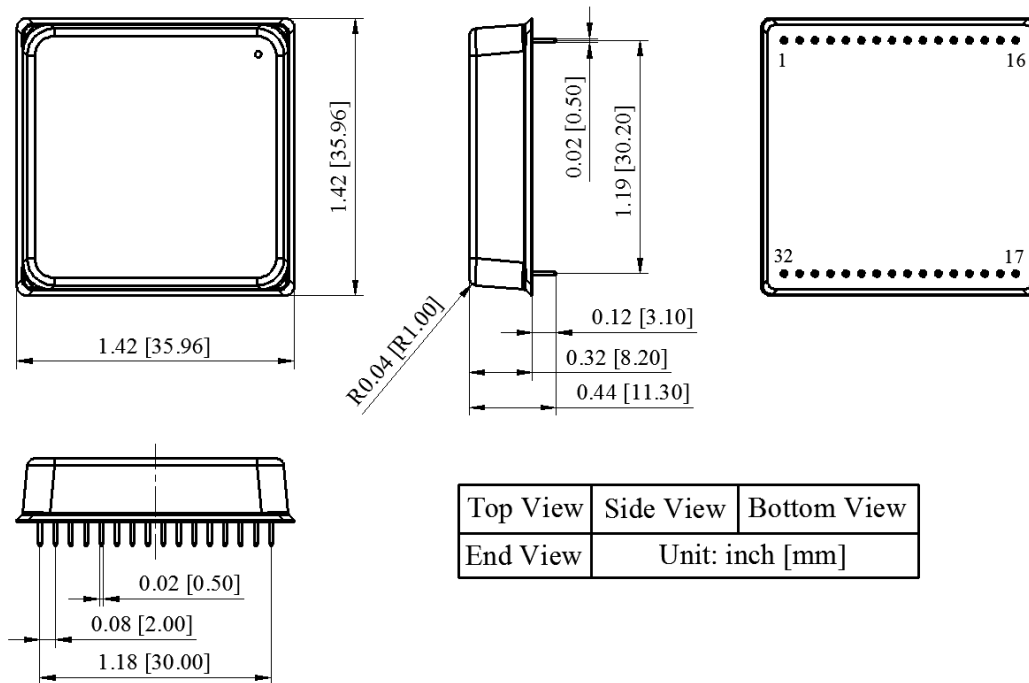

Figure 28. Dimensions of DIP Package

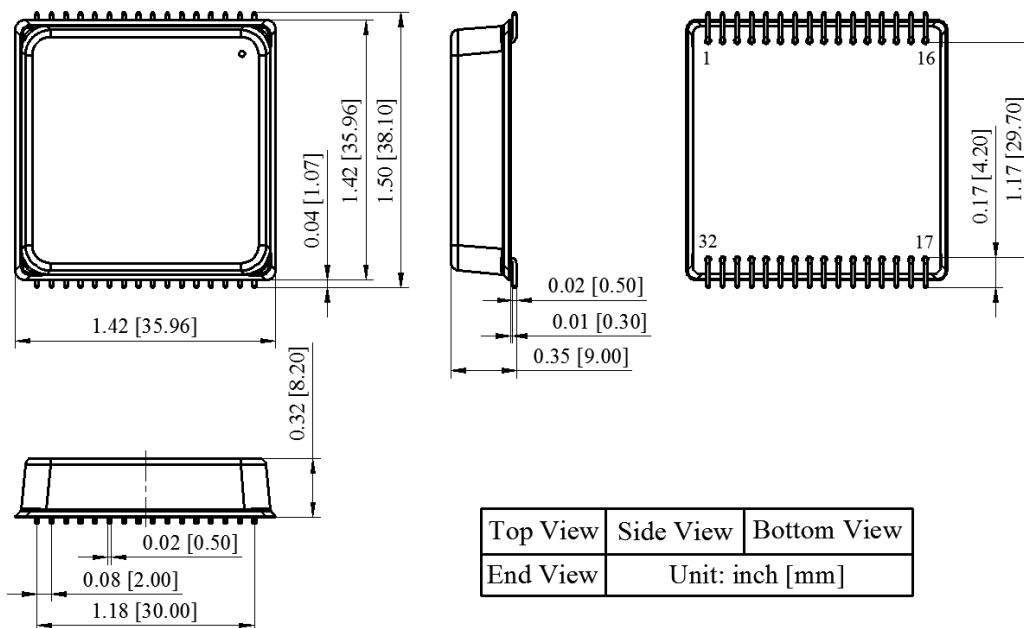

Figure 29. Dimensions of SMT Package



ORDERING INFORMATION

Table 5. Part Number

Part Number	Description
TEC9V6AD	DIP package, with Pin 1 4VRS.
TEC9V6AS	SMT package, with Pin 1 4VRS.
TEC9V6ASNCOD	DIP package, with Pin 1 SNCO.
TEC9V6ASNCOS	SMT package, with Pin 1 SNCO.
TEC9V6ADAPID	DIP package, with Pin 1 4VRS and with auto PID function.
TEC9V6ASAPID	DIP package, with Pin 1 4VRS and with auto PID function.

NOTICE

- ATI warrants performance of its products for one year to the specifications applicable at the time of sale, except for those damaged by excessive abuse. Products found not meeting the specifications within one year from the date of sale can be exchanged free of charge.
- ATI reserves the right to make changes to its products or to discontinue any product or service without notice and advise customers to obtain the latest version of relevant information to verify, before placing orders, that the information being relied on is current and complete.
- All products are sold subject to the terms and conditions of sale supplied at the time of order acknowledgment, including those pertaining to warranty, patent infringement, and limitation of liability. Testing and other quality control techniques are utilized to the extent ATI deems necessary to support this warranty. Specific testing of all parameters of each device is not necessarily performed, except those mandated by government requirements.
- Customers are responsible for their applications using ATI products. In order to minimize risks associated with the customers' applications, adequate design and operating safeguards must be provided by the customers to minimize inherent or procedural hazards. ATI assumes no liability for applications assistance or customer product design.
- ATI does not warrant or represent that any license, either expressed or implied, is granted under any patent right, copyright, mask work right, or other intellectual property right of ATI covering or relating to any combination, machine, or process in which such products or services might be or are used. ATI's publication of information regarding any third party's products or services does not constitute ATI's approval, warranty or endorsement thereof.
- IP (Intellectual Property) Ownership: ATI retains the ownership of full rights for special technologies and/or techniques embedded in its products, the designs for mechanics, optics, plus all modifications, improvements, and inventions made by ATI for its products and/or projects.