

Figure 1. Physical Photo of TEC50V20ACH

FEATURES

- **Built-in Smart Auto PID Control – the World's First**
- **Power Supply Voltage: 50V**
- **High Output Voltage: $\pm 40V$**
- **High Output Current: 20A**
- **High Efficiency: > 92%**
@ $V_{PS} = 50V$ & $V_{TEC} = 25V$ & $I_{TEC} = 20A$
- **High Temperature Stability: $< \pm 0.001^{\circ}C$**
- Low Thermistor Injection Current: $< 1\mu A$
- Continuous Bi-directional Output
- Programmable Output Current and Voltage Limits
- Real Time Temperature, Current and Voltage Signals
- Selectable Temperature Sensor Types: thermistor, RTD, or temperature sensor IC
- High Reliability and Zero EMI
- Compact Size: 63(L) \times 61(W) \times 16.7(H) (mm)
100 % Lead (Pb)-free and RoHS Compliant

APPLICATIONS

Driving high power TEC modules at high efficiency.

DESCRIPTION

TEC (Thermo-Electric Cooler) is a semiconductor device which can cool down or heat up the temperature of an object by injecting an electrical current in one or the other direction. This TEC controller, TEC50V20ACH, is designed to drive a TEC at high efficiency for regulating the object temperature precisely by controlling the direction and magnitude of the current going through the TEC. It is powered by a DC voltage between 10V to 50V and the output current can go up to 20A without using a heat sink. Figure 1 is the photo of the TEC controller TEC50V20ACH, Pin 1 to pin 18 shows the signal pins, and the others are power pins. See Figure 2.

The controller TEC50V20ACH allows setting the set-point temperature, maximum output voltage magnitude, and the maximum output current magnitude respectively. These three settings are the input parameters for the three control loops: constant temperature, constant current, and constant voltage. Before hitting the maximum output voltage magnitude or the maximum output current magnitude, the temperature loop is in control. When hitting the maximum output voltage magnitude, either outputting a positive or negative value across the TEC, the voltage loop takes over the control, the controller will be outputting a constant voltage to the TEC; when hitting the maximum output current magnitude, the current loop takes over the control, the controller will be outputting a constant output current to the TEC. The highest output voltage magnitude is limited by the maximum power supply voltage, and the maximum output current magnitude is 20A.

The temperature signal can be obtained by using one of these 3 temperature sensors: thermistor, RTD or temperature sensor IC. When using a thermistor, the set-point temperature range is determined by an external temperature network formed by 3 resistors. In order to reduce the injection current to the thermistor to reduce the errors caused by the self-heating effect, the injection current is provided in pulse mode, reducing the current by 10 times as opposed to a continuous current.

One advanced feature of this TEC controller is that it comes with a smart auto PID control micro-processor, it continuously senses and compensates for the thermal load automatically. No need to use any external components for forming a compensation network, nor requires tuning.*

*Firmware PID control – currently not available.

Conservative users can still select the conventional analog compensation network. The same as in the past, it requires a onetime pre-tuning network to match the



thermal load, but provides reliable and high accuracy control. For fixed thermal load applications, conventional analog compensation can be selected; while for applications with variable or multiple different thermal loads – one type at a time, the automatic PID control is more suitable.

Figure 2 is the top view of the controller, showing the pin names and the locations. There are a total of 22 pins. Pins No.1 to No.18 are control input or indicator output signals; the rest of the pins are power inputs or outputs. The pin function details are given in Table 1.

At the thermistor input, there is a linearization circuit for the thermistor, to make the temperature output voltage be more linearly proportional to the actual thermistor temperature. There is a voltage inverter circuit, and it makes the temperature output voltage be positively proportional to the temperature, since the thermistor has a negative temperature coefficient. These 2 circuits together are called temperature measurement circuit. See Figure 6.

The set-point temperature voltage and the voltage representing the actual temperature are sent to an error amplifier. There is a compensation network inserted in the loop, to stop the oscillation of the controller caused by phase delay effects of the thermal load. Therefore, the compensation network must match the need for driving a particular thermal load. To simplify the tuning, a tunable compensation network is provided by the evaluation board for this TEC controller. Of course, users can also use an external compensation network

if they need it. A detailed guidance about how to tune the compensation network with a thermal load is given in the evaluation board application note.

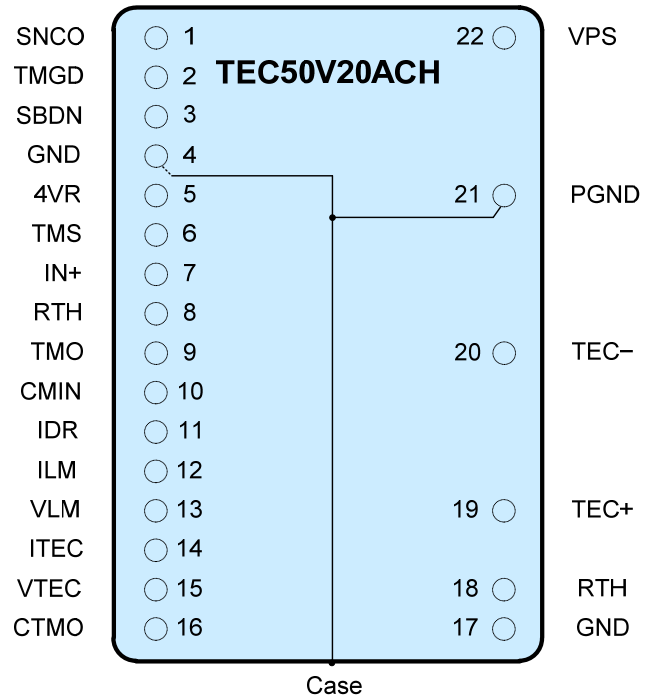

Figure 2. Pin Names and Location



SPECIFICATIONS

Table 1. Pin Function Descriptions

Pin #	Name	Note	Description
1	SNCO	Digital output	Synchronization output. This pin outputs a switching pulse signal, from 0V to 5V, 600kHz. It can be sent to the synchronization input of another SM (Switch Mode) controller or power supply, to eliminate the beating interference between this TEC controller and the other SM device.
2	TMGD	Digital output	Temperature good indication. Active high. Indicates when actual temperature equals to the set-point temperature of the target object. That is, the target object temperature is within 0.001°C away from the set-point temperature, provided the set-point temperature range is 40°C. Or $ V_{TMO}-V_{TMS} < 0.5mV$.
3	SBDN	Analog /Digital input	Standby and shut down control. This SBDN pin is internally floated and series with 1k resistor. It's suggested to pull this pin up to VPS power supply by a 4.99MΩ resistor. If pulled to ground, it shuts down the entire controller. This pin has 2 threshold voltages: 1.5V and 2.0V. See Figure 5. SHUT DOWN: $V_{SBDN} < 0.3V$, the controller is set to non-working state. STANDBY: $1.9V > V_{SBDN} > 1.5V$, all components are set to working state except the output stages for TEC+ and TEC-. OPERATION: $V_{SBDN} > 2.0V$, the whole controller is set to working state.
4	GND	Ground	Signal ground. Connect this pin to the signal ground of ADCs, DACs, and the signal sources. It can also be used as analog output pin ground.
5	4VR	Analog output	Reference voltage output, 4.096V. It can be used as the voltage reference by the potentiometers or DACs for setting the analog ports, such as TMS, ILM, VLM, etc. It can also be used by ADCs for sensing the analog output ports: TMO, CTMO, ITEC and VTEC. The initial accuracy is 0.1%, and the temperature coefficient is <50ppm/°C max.
6	TMS	Analog input	Analog Input port for setting the set-point temperature for the target object. It is internally tied a 1MΩ resistor to the half value of the reference voltage, 2V. The open circuit voltage of this pin is thus 2V, corresponding to a set-point temperature of 25°C by using the default temperature network (with the set-point temperature range being from 15°C to 35°C). It is highly recommended to set this pin's voltage by using the controller's 4V voltage reference. This pin can be set by using a POT or DAC. When the set-point temperature needs to be at 25°C, leave this pin unconnected.
7	IN+	Analog input	Receive external temperature signal (thermistor and temperature sensor, etc.)



Pin #	Name	Note	Description
8	RTH	Analog input	Thermistor connection port. Connect to the thermistor which is mounted on the target object for sensing its temperature. By using the default internal temperature network, a 10kΩ @ 25°C thermistor can be used. Other type of thermistors or temperature sensors can also be used, see the application section for details.
9	TMO	Analog output	Actual target object temperature indication. It swings from 0V to 4V. By using a default internal temperature network, it represents 15°C to 35°C when this pin's voltage swings 0.1V to 3.9V linearly, provided a standard 10kΩ thermistor is used as the temperature sensor device.
10	CMIN	Analog input	Compensation input pin for the thermal control loop.
11	IDR	Analog input and output	This voltage is derived from the temperature error detection circuit and used as the input control signal of the current loop for the TEC. Its internal impedance is 10kΩ and can be over-driven by an external analog signal which is able to over-ride the 10kΩ resistor. The voltage range is from 0V to 4V, corresponding to -20A to +20A output current. Setting this pin voltage to 2V forces the output current to zero.
12	ILM	Analog input	This pin sets the TEC Current Limit. The maximum limit current is 20A. Setting this pin's voltage from 0V to 4V corresponds to setting the current magnitude limit from 0A to 20A: $V_{ILM} = \frac{ I_{OUT}(A) _{MAX}}{3.75}$
13	VLM	Analog input	This pin sets the TEC voltage Limit. The maximum limit voltage is 50V. Setting this pin's voltage from 0V to 4V corresponds to the TEC voltage magnitude limit being from 0 to 50V: $V_{VLM} = \frac{ V_{TEC+} - V_{TEC-} _{MAX}}{7.5}$
14	ITEC	Analog output	TEC current indication. ITEC is an analog voltage output pin with a voltage proportional to the actual current through the TEC. ITEC's center voltage is 2V, corresponding to zero current through the TEC. $V_{ITEC} = \frac{I_{OUT}(A)}{7.5} + 2V$, where I_{OUT} is the actual output current of the controller, flowing out from TEC+ port and flowing in to TEC- pin.
15	VTEC	Analog output	TEC voltage indication. VTEC is an analog voltage output pin with a voltage proportional to the actual voltage across the TEC. It swings from 0V to 4V to indicate the output voltage being from -50V to 50V, so the center voltage is 2V. $V_{VTEC} = \frac{V_{TEC+} - V_{TEC-}}{15} + 2V$



Pin #	Name	Note	Description
16	CTMO	Analog output	The controller internal temperature indication output. It can be used for sensing the actual temperature of the controller, to avoid over-heating.
17	GND	Ground	Signal ground. Connect this pin to the signal ground of ADCs, DACs, and the signal sources. It can also be used as analog output pin ground.
18	RTH	Analog input	Thermistor connection port. Connect to the thermistor which is mounted on the target object for sensing its temperature. By using the default internal temperature network, a 10kΩ @ 25°C thermistor can be used. Other type of thermistors or temperature sensors can also be used, see the application section for details.
19	TEC+	Analog power output	This pin is used to connect to the front end of the TEC module to improve the current capability.
20	TEC-	Analog power output	This pin is for connecting to the negative terminal of the TEC module.
21	PGND	Power ground	Power ground for connecting to the power supply 0V return node.
22	VPS	Power input	Power supply voltage positive node. The normal operating voltage range is 10V to 50V, the maximum value is 50V.
	S1	Dial the code switch	Set the controller to different states and choose different types of temperature sensors to use.
	S4,S5, S6,S7, S8	Dial the code switch	Adjustment approach for resistors (Rd, Ri and Rp) and capacitors (Cd and Ci). See Table 4 for switch function details.



ELECTRICAL CHARACTERISTICS

Parameter	Symbol	Conditions	Min.	Typ.	Max.	Units
Reference Voltage	V _{4VRSOUT}	T _A = 25°C	4.0925	4.096	4.0995	V
Initial Error	V _E	T _A = 25°C	-0.05		0.05	%
Temperature Coefficient	T _C			±3	±8	ppm/°C
Maximum Load Current	I _{4VRMAX}	T _A = 25°C	-20		+20	mA
Switch frequency	F _{4VRS}		83	85	87	Hz
Output Voltage (Open circuit)	V _{SNCOOUT}	Open circuit voltage = 0V ~ 4V PWM	0		4	V
Voltage Range (with load)	V _{SNCOOUT}	Open circuit voltage = 0V ~ 4V PWM	0.1		3.9	V
Frequency	F _{SNCO}	Open circuit voltage = 0V ~ 4V PWM		600		kHz
Temperature Good Indication: TMGD pin, pin 1						
Voltage Range (Open circuit)	V _{TMGDOUT}	Open circuit voltage = 4V	0		4	V
Voltage Range (with load)	V _{TMGDOUT}	Open circuit voltage = 4V	0		4	V
Maximum Sourcing Current	I _{TMGDSC}	Open circuit voltage = 4V	1		15	mA
Maximum Sourcing Voltage	V _{TMGDSC}	Open circuit voltage = 4V	3.7		4	V
Maximum Sinking Current	I _{TMGD SK}	Open circuit voltage = 4V	3		20	mA
Maximum Sinking Voltage	V _{TMGD SK}	Open circuit voltage = 4V	0		0.6	V
Standby Shutdown Control: SBDN pin, pin 3						
Input Current	I _{SBDNIN}	V _{SBDN} = 0V	0.1		0.3	µA
		V _{SBDN} = 4V	4		6	
		V _{SBDN} = 50V	50		50	
Input Voltage Range	V _{SBDNIN}	Open circuit voltage = 5V	0		50	V
Shutdown Logic Low	V _{SBDNSDL}	Open circuit voltage = 5V	0			V
Shutdown Logic High	V _{SBDNSDH}	Open circuit voltage = 5V			0.7	V
Standby Logic Low	V _{SBDNSBL}	Open circuit voltage = 5V	1.4			V
Standby Logic High	V _{SBDNSBH}	Open circuit voltage = 5V			1.9	V
Operation Logic Low	V _{SBDNOPL}	Open circuit voltage = 5V	2.0			V
Operation Logic High	V _{SBDNOPH}	Open circuit voltage = 5V			5	V



Parameter	Symbol	Conditions	Min.	Typ.	Max.	Units
Reference Voltage Output: 4VR pin, pin 5						
Output Voltage Range	V _{4VROUT}	T _A = 25°C	4.0925	4.096	4.0995	V
Initial Error	V _E	T _A = 25°C		0.05		%
Temperature Coefficient	T _C	T _A = -40°C ~ 125°C		3	8	ppm/°C
Maximum Load Current	I _{4VRMAX}	T _A = 25°C	-20		+20	mA
Maximum Load Capacitance	C _{4VRMAX}		0.1		1	uF
Temperature Set: TMS pin, pin 6						
Input Impedance (See Figure 3 in Page 8 for input equivalent circuit)	Z _{TMSIN}			5		MΩ
Input Voltage Range	V _{TMSIN}		0		4	V
Open Circuit Voltage	V _{TMSOP}			2		V
Temperature Signal Input: IN+ pin, pin 7						
Input Voltage Range	V _{IN+}		0		4	V
Thermistor Connection Port: RTH pin, pin 8, pin 18						
Input Voltage Range	V _{RTHIN}		0		4	V
Actual Target Object Temperature Indication: TMO pin, pin 9						
Output Voltage Range	V _{TMOOUT}	R _{LOAD} = 10kΩ to 2V -40°C ≤ T _A ≤ +125°C	0		4	V
Output Current	I _{TMOOUT}	V _{SS} = 0V T _A = 25°C	-12		12	mA
Compensation Input: CMIN pin, pin 10						
Input Voltage Range	V _{CMIN}	R _{LOAD} = 10kΩ to 2V -40°C ≤ T _A ≤ +125°C	0		4	V
Input Current	I _{CMIN}	-40°C ≤ T _A ≤ +125°C		90	200	pA
Compensation Output: IDR pin, pin 11						
Output Voltage Range	V _{IDROUT}	R _{LOAD} = 10kΩ to 2V -40°C ≤ T _A ≤ +125°C	0		4	V
TEC Current Limit: ILM pin, pin 12						
Input Impedance	Z _{ILM}			21		kΩ
Input Voltage Range	V _{ILMIN}		0		4	V



Parameter	Symbol	Conditions	Min.	Typ.	Max.	Units
TEC Voltage Limit: VLM pin, pin 13						
Input Impedance (See Figure 4 in Page 8 for input equivalent circuit)	Z _{VLM}			10		kΩ
Input Voltage Range	V _{VLMIN}		0		4	V
TEC Current Indication: ITEC pin, pin 14						
TEC Voltage Indication: VTEC pin, pin 15						
Controller Temperature Indication: CTMO pin, pin 16						
Output Voltage Range	V _{CTMO}	T _A = 25°C	0		4	V
Maximum Load Current	I _{CTMOOUT}	T _A = 25°C	-12		12	mA
TEC+/TEC- pin, pin 19/pin 20						
Maximum Output Current	I _{MAXTEC+} I _{MAXTEC-}	V _{PS} = 50V T _A = 25°C	0		20	A
Maximum Output Voltage	V _{OUTMAX}	V _{VPS} = 50V	0		40	V
Power Supply Input: VPS pin, pin 22						
Input Voltage Range	V _{VPS}		5		50	V
Input Current	I _{VPS}	Operation mode	0.05		16	A
	I _{VPS} SB	Standby mode	5		20	mA
	I _{VPS} SD	Shutdown mode			50	μA
Temperature Stability						
Temperature Error Voltage	V _{TMO} -V _{TMS}		-0.47	0.02	0.47	mV
Efficiency	η	V _{VPS} = 50V V _{TEC+} - V _{TEC-} = 14V I _{TEC+} - I _{TEC-} = 20A		≥92		%
Case Operating Temperature Range	T _{CS}		-40		110	°C
Ambient Operating Temperature Range	T _A		-40		65	°C
Storage Temp. Range	T _{STG}		-40		125	°C
Controller Case Thermal Resistance	R _{TH}			9		°C/W



This TEC controller can only drive the TECs having >1Ω impedance, which equals V_{MAX} / I_{MAX} .

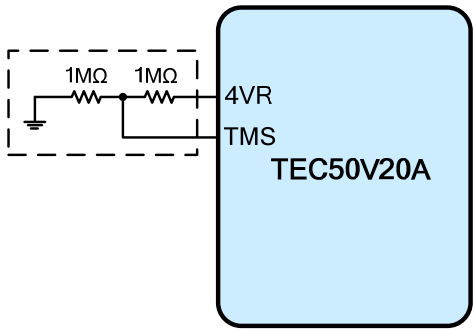

Figure 3. TMS Input Equivalent Circuit

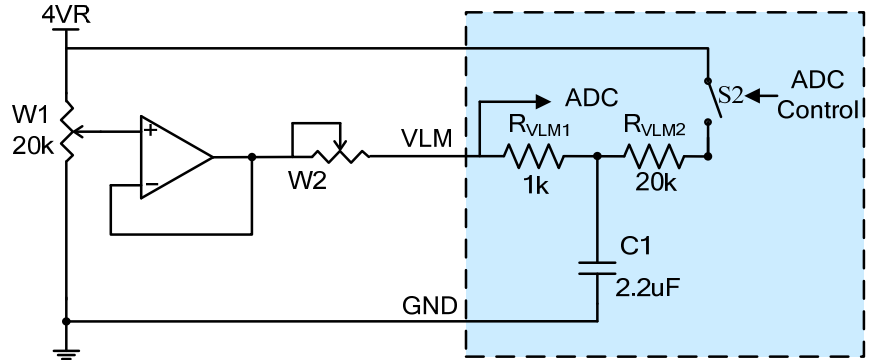

Figure 4. VLM Input Equivalent Circuit
The switch S2 is closed @ heating, and open @ cooling

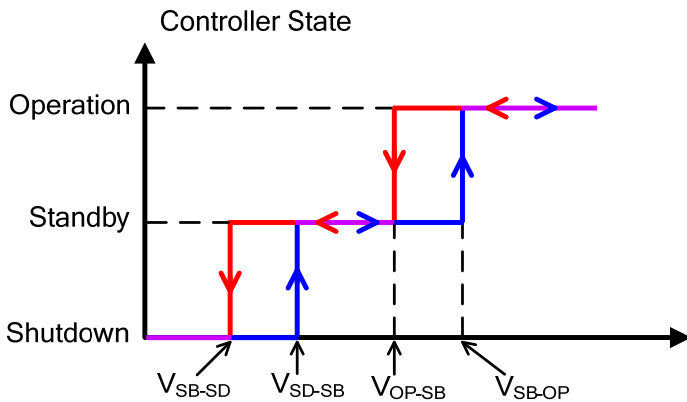

Figure 5. Controller States

- V_{SB-SD} : Going down logic low from standby to shutdown
- V_{SD-SB} : Going up logic high from shutdown to standby
- V_{OP-SB} : Going down logic low from operation to standby
- V_{SB-OP} : Going up logic high from standby to operation



BLOCK DIAGRAM

The block diagram of the controller is shown in Figure 6.

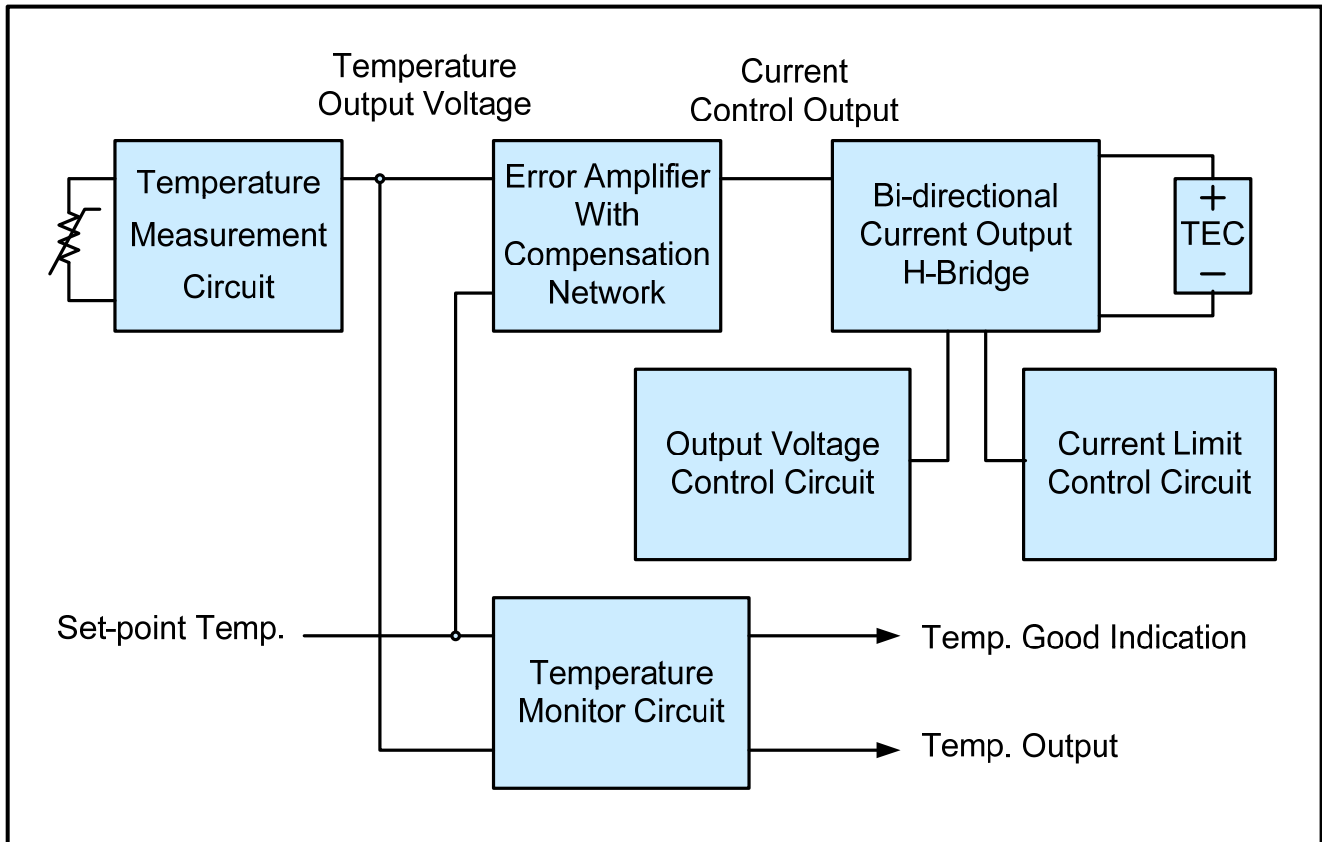

Figure 6. TEC Controller Block Diagram



APPLICATIONS

TEC controller connections are shown in Figure 7.

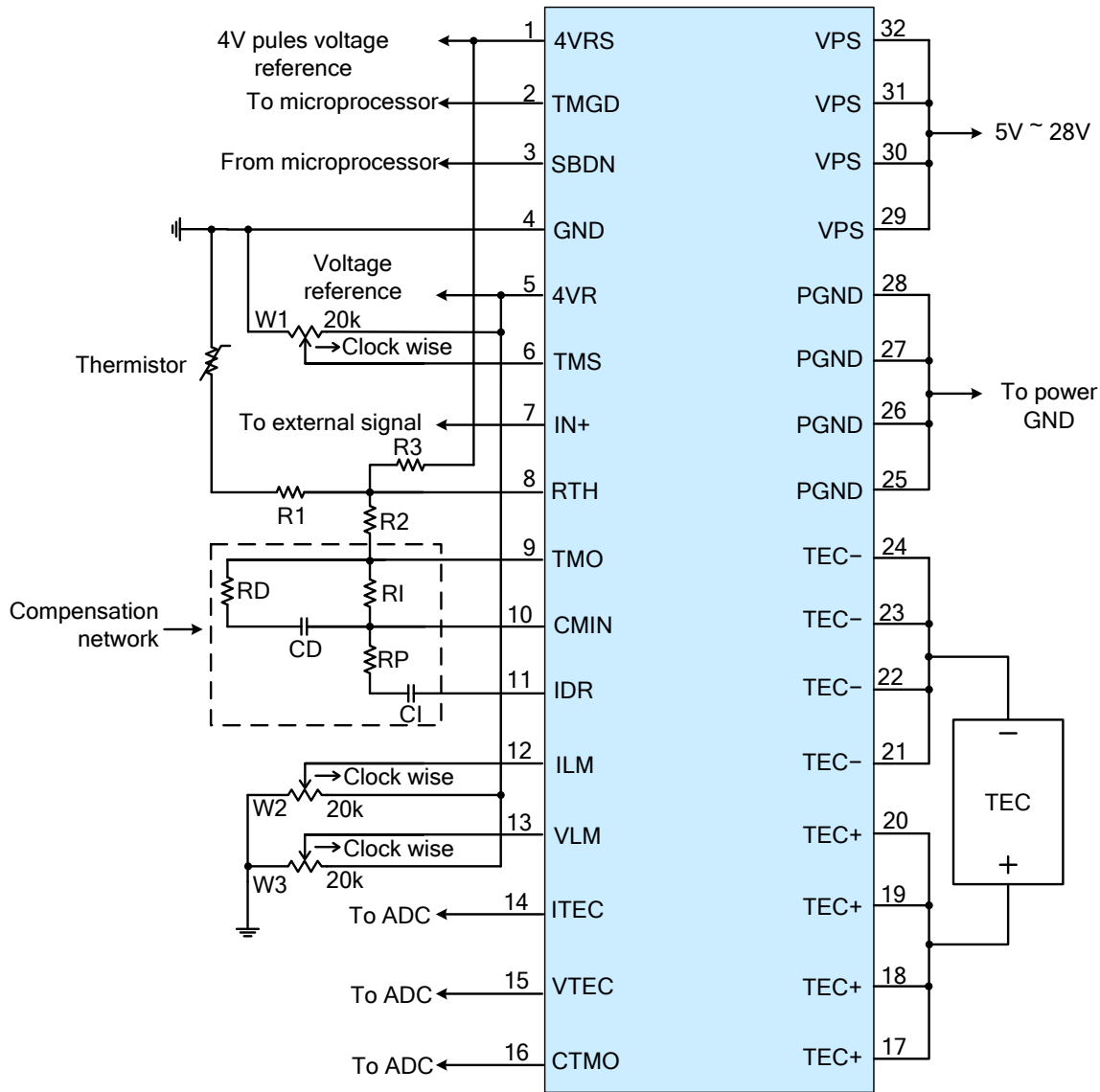

Figure 7. TEC Controller Connection



Temperature Sensor Selections

There are usually three temperature sensors, thermistor, RTD (Resistance Temperature Detector), and IC (Integrated Circuit) temperature sensors.

1. Thermistor

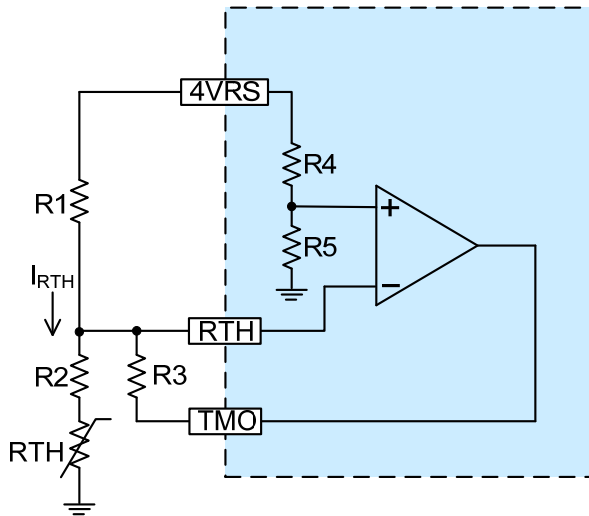

Figure 8. Thermistor

To achieve the required V_{TMO} outputs at the three different setting point temperatures in the Temperature Network, use the equation:

$$R1 = R_{MID} + \frac{R_{MID} \times (R_{LOW} + R_{HIGH}) - 2 \times R_{HIGH} \times R_{LOW}}{R_{HIGH} + R_{LOW} - 2 \times R_{MID}}$$

(1)

$$R2 = R1 - R_{MID}$$

(2)

$$R3 = \frac{R1 \times (R1 + R_{LOW} - R_{MID})}{R_{LOW} - R_{MID}}$$

(3)

For example, setting the high set-point temperature at 35°C and the low set-point temperature at 15°C results in a middle set-point temperature $(35 + 15)/2 = 25^\circ\text{C}$. Use the R-T table of a thermistor.

$$R_{HIGH} = 6.9\text{k}\Omega$$

$$R_{MID} = 10\text{k}\Omega$$

$$R_{LOW} = 14.8\text{k}\Omega$$

Note that Equation 1 to Equation 3 result in

$$R1 = 17.5\text{k}\Omega$$

$$R2 = 7.5\text{k}\Omega$$

$$R3 = 81.3\text{k}\Omega$$

In order to reduce the injection current to the thermistor to reduce the errors caused by the self-heating effect, the injection current is provided in pulse mode, reducing the current by 10 times as opposed to a continuous current.

It's recommended to connect R1 to SNCO, and the controller will measure temperature at intervals that will reduce the error caused by the RTH self-heating. At the same time, the SBDN pin should be between 2.8V and 4V. See Table 3.

We can also connect R1 to 4VR, but it may lead to some errors caused by RTH self-heating. At the same time, SBDN pin should be between 2.4V and 2.7V. See Table 3.

Table 3. External Detector Selection.

No.	Input	Voltage	External Detector
1	SBDN	0V ~ 0.5V	SD
2	SBDN	1.5V ~ 1.9V	SB
3	SBDN	2V ~ 2.3V	Temperature sensor
4	SBDN	2.4V ~ 2.7V	RTD/RTH
5	SBDN	2.8V ~ 4V	RTH (pulse mode)

2. RTD

RTD is short for resistance temperature detector, which features high accuracy and low drift. It usually generates heat when the current flows through the RTD, which is called self-heating effect. Moreover, RTD has an approximate linear resistance-temperature relationship.

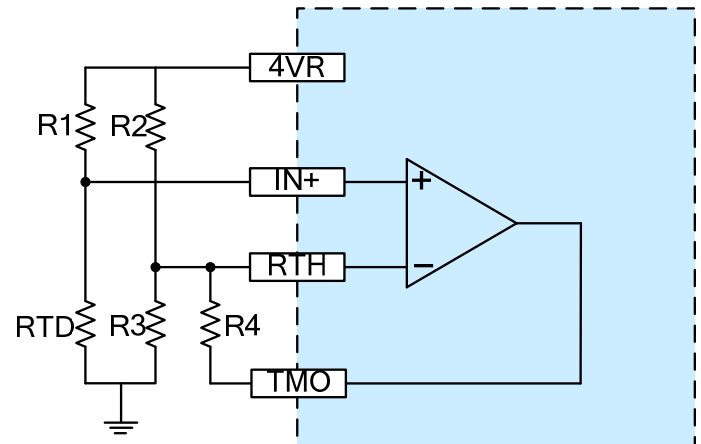

Figure 9. RTD

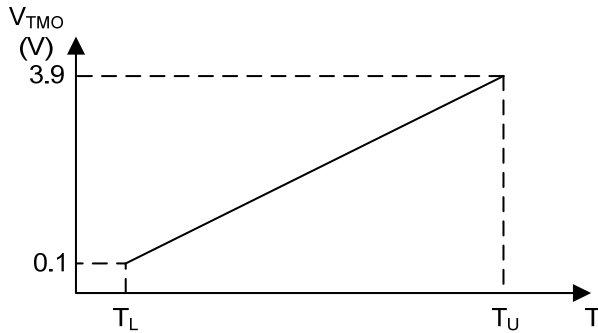

Figure 10. Linear Relationship between V_{TMO} and Temperature

$$R_{TD} = R_0 \times (1 + 0.00385T)$$

e.g. $R_0 = 1k\Omega$

When $T = 10^\circ\text{C}$, $R_{TD}(10) = 1.0385k\Omega$

When $T = 40^\circ\text{C}$, $R_{TD}(40) = 1.154k\Omega$

Choose R_1

A. $P_{RTD} \leq 1\text{mW}$, $R_{TD} = 1000\Omega$

$$P_{RTD} = (I_{RTD})^2 \times 1000\Omega = 0.001\text{W}$$

$$I_{RTD} = 1\text{mA} = \frac{4\text{VR}}{R_1 + R_{TD}} = \frac{4}{R_1 + 1k} \Rightarrow R_1 = 3k\Omega$$

B. $P_{RTD} \leq 1\text{mW}$, $R_{TD} = 100\Omega$

$$P_{RTD} = (I_{RTD})^2 \times 100\Omega = 0.001\text{W}$$

$$I_{RTD} = 3.16\text{mA} = \frac{4\text{VR}}{R_1 + R_{TD}} = \frac{4}{R_1 + 0.1k} \Rightarrow R_1 = 1.15k\Omega$$

$R_1 = 1.15k\Omega$

$$V_{TMO} = \frac{4 \times R_{TD}}{R_1 + R_{TD}} \times \left[1 + \frac{R_4 \times (R_2 + R_3)}{R_2 \times R_3} \right] - \frac{4 \times R_4}{R_2}$$

I. When $T = 10^\circ\text{C}$, $R_1 = 3k\Omega$, $R_{TD}(T_L) = 1.0385k\Omega$,

$$0.93 = \frac{R_4 \times (2.97R_3 - 1.03R_2)}{R_2 \times R_3}$$

When $T = 40^\circ\text{C}$, $R_1 = 3k\Omega$, $R_{TD}(T_U) = 1.154k\Omega$,

$$2.79 = \frac{R_4 \times (1.11R_2 - 2.89R_3)}{R_2 \times R_3}$$

II. When $T = 10^\circ\text{C}$, $R_1 = 1.15k\Omega$, $R_{TD}(T_L) = 1.0385k\Omega$,

$$1.8 = \frac{R_4 \times (2.1R_3 - 1.9R_2)}{R_2 \times R_3}$$

When $T = 40^\circ\text{C}$, $R_1 = 1.15k\Omega$, $R_{TD}(T_U) = 1.154k\Omega$,

$$1.9 = \frac{2 \times R_4 \times (R_2 - R_3)}{R_2 \times R_3}$$

3. IC

IC temperature sensor has lower self-heating effect. We use LM62BIM temperature sensor. The temperature range is from 10°C to 50°C , corresponding to $T_L = 0.636\text{V}$, and $T_U = 1.260\text{V}$. $R_1 = 16.4k$, $C_1 = 4.7\mu\text{F}$, $R_2 = 100k$, $R_3 = 97.8k$, $R_4 = 19.7k$, $R_5 = 100k$. See Figure 11.

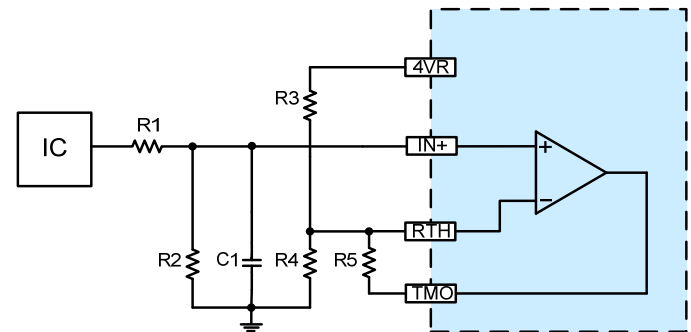

Figure 11. IC temperature sensor

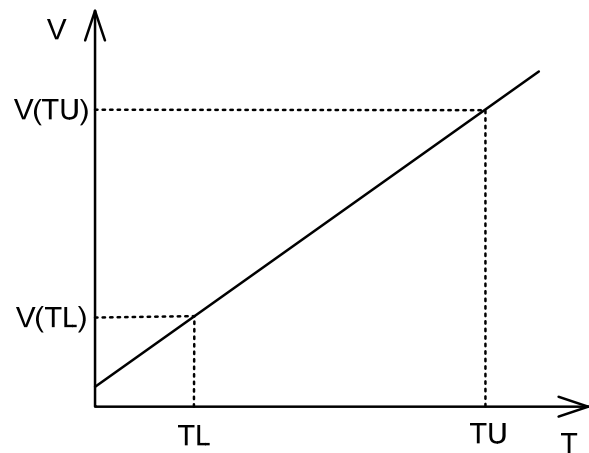

Figure 12. Temperature sensor IC characteristics

$$V_{TMO}(T_L) = 0.1\text{V}, V_{TMO}(T_U) = 3.9\text{V}$$

$$G = \frac{\Delta V_O}{\Delta V_i} = \frac{V_{(TMO)}(T_U) - V_{(TMO)}(T_L)}{V(T_U) - V(T_L)}$$

$$G = \frac{R_2}{R_1} = \frac{R_5}{R_3 // R_4}$$

$$V_{IM} = \frac{V(T_U) + V(T_L)}{2}, V_{OM} = \frac{3.9\text{V} + 0.1\text{V}}{2} = 2\text{V}$$

$$V_i = V_{IM}, V_{OM} = 2\text{V}$$

V_i is the output voltage of IC, and V_o is the voltage of TMO pin.

$$V_{IN+} = \frac{R_2}{R_1 + R_2} V_{im}, V_{RTH} = V_{IN+}$$



$$\frac{4V - V_{IN+}}{R3} + \frac{V_{om} - V_{IN+}}{R5} = \frac{V_{IN+}}{R4}$$

R5=100k, R1=R3//R4, R2=R5.

$$R4 = \frac{400}{4G - V_{IN+} - V_{IN+}G + 2}$$

$$R3 = \frac{400}{V_{IN+} + V_{IN+}G - 2}$$

SBDN

SBDN is suggested to be pulled up to VPS with a 10µA current and contains a 1.50V logic threshold. Drive this pin to a logic-high to enable the TEC50V20ACH. Drive to a logic-low to disable the TEC controller and enter micro-power shutdown mode.

ITEC and ILM

When the voltage of the ITEC is $V_{ITEC} = 2V$, the current of the TEC Controller $I_{TEC}=0A$. When $V_{ITEC} = 0V$, I_{TEC} has the maximum reverse current, $-20A$. When $V_{ITEC} = 4V$, I_{TEC} has the maximum forward current, $20A$. TEC controller is working on the cooling region, when it has forward current. On the opposite, it works on the heating region when reversing the current, as shown in Figure 13.

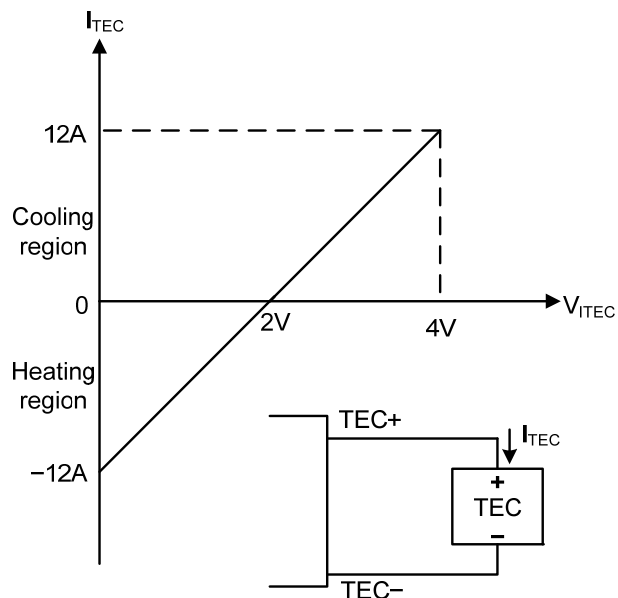

Figure 13. V_{ITEC} vs. I_{TEC}

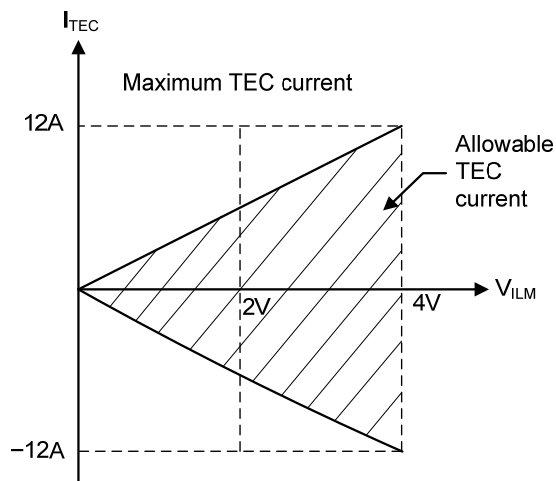

Figure 14. V_{ILM} vs. I_{TEC}

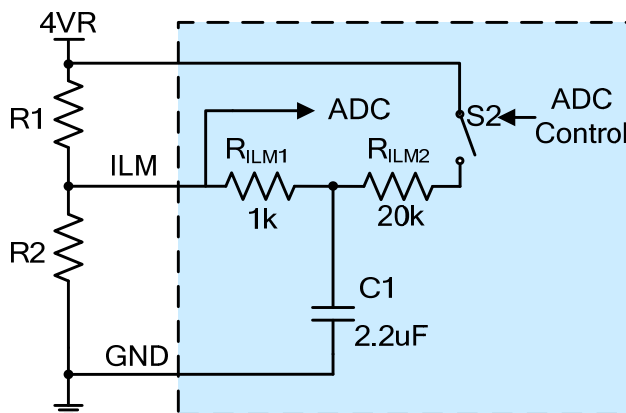

Figure 15. ILM vs. Cooling and Heating Control
The switch S1 is closed @ heating, and open @ cooling

Calculate the maximum current in cooling and heating region according to Figure 15.

1. Cooling region

$I_{TEC} \geq 0A$, $V_{ILM} \geq 2V$, Cooling region => S1 = Open;

Maximum cooling current:

$$I_{TEC} \leq \frac{V_{ILM}}{4V} \times 20A = \frac{R2}{R1 + R2} \times 20A$$

2. Heating region

$I_{TEC} < 0A$, $V_{ILM} < 2V$, Heating region => S1 = Close;

Maximum heating current:

$$|I_{TEC}|_{MAX} \leq \frac{V_{ILM}}{4V} \times 20A = \frac{R2/R_{ILM}}{R1 + R2/R_{ILM}} \times 20A$$



3. After deciding the heating current shrinking ratio, we can determine the value for R1 & R2.

Calculate R1 & R2 ratio

$$I_{COOLMAX} = \frac{R1}{R1+R2} \times 20A \quad \text{-----(1)}$$

Calculate R1 & R2 value by deciding the heating current shrinking ratio:

KHC = maximum heating current / maximum cooling current

$$= \frac{I_{TEC-(TH-MAX)}}{I_{TEC-(CL-MAX)}} \quad \text{-----(2)}$$

$$= \frac{R2//R_{ILM}}{R1 + R2//R_{ILM}}$$

$$= \frac{R2}{R1 + R2}$$

$$= \frac{200 \times (R1 + R2)}{R1 \times R2 + 200 \times (R1 + R2)}$$

VTEC and VLM

VTEC = VTEC+ - VTEC-, as shown in Figure 17.

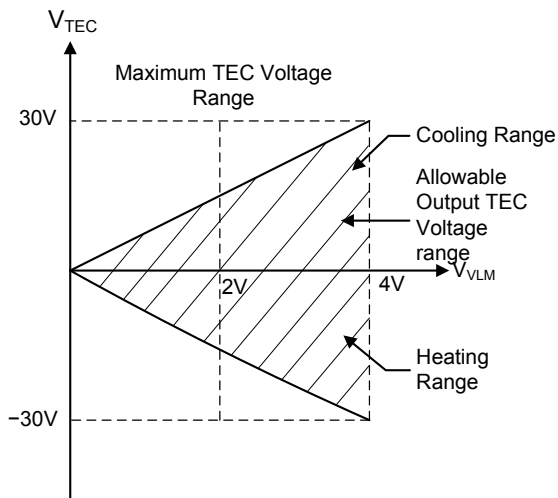

Figure 16. VTEC vs. VVLM

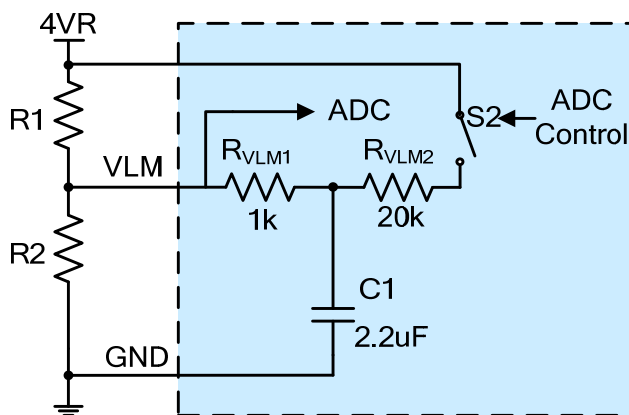

Figure 17. VLM vs. Cooling and Heating Control

The switch S2 is closed @ heating, and open @ cooling

TMGD

The TMGD pin outputs the maximum source current and sink current of 20mA. The output current will cause voltage drop, see Figure 18.

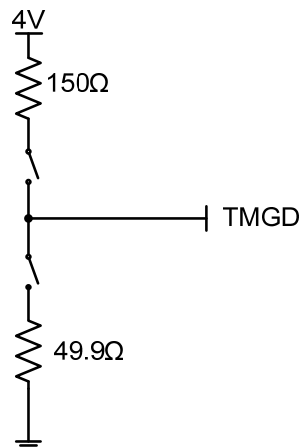

Figure 18. TMGD Output Voltage Range

VLM and ILM

If you want to use this TEC controller for other applications not discussed here, such as with wave locker controllers, consult with us. The same for other customizations, such as setting the ILM and VLM by using voltage source swings above 4V and/or VPS.

An external voltage connects the ILM pin through a resistor. This voltage can be used to adjust the voltage range of cooling or heating, and advice is 1.5V. The resistor can be used to adjust the difference of cooling and heating, and advice is 10kΩ. See Figure 19.

For example, the voltage midpoint of the ILM pin (Vm) is 2V. Adjust the external voltage, and make the



voltage range 1V, but it is only with the center of 2V (V_m). If you adjust the resistor W2, you can move the limit of the cooling to be greater than the limit of the heating. It is shown in Figure 20 and Figure 21.

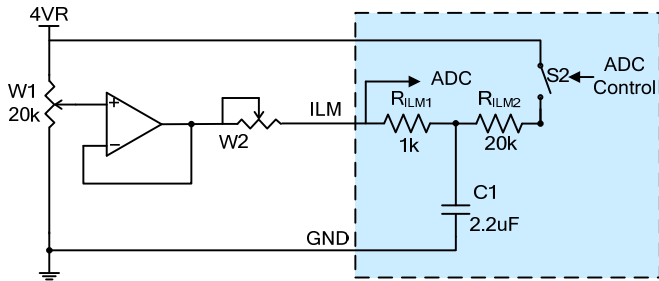

Figure 19. ILM vs. Cooling and Heating Control 2

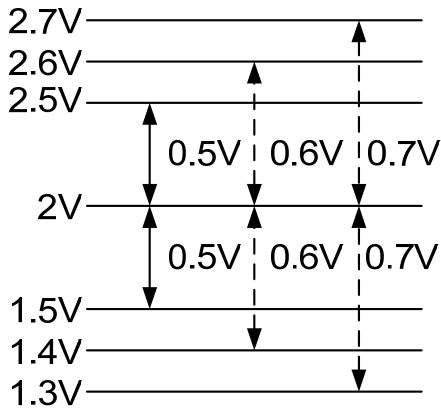

Figure 20. Adjust the External Voltage

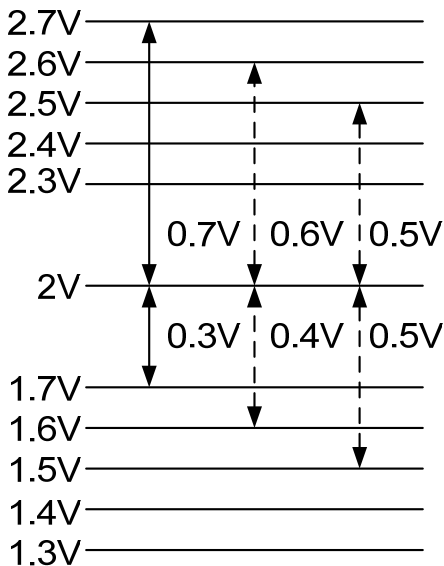

Figure 21. Adjust the Resistor

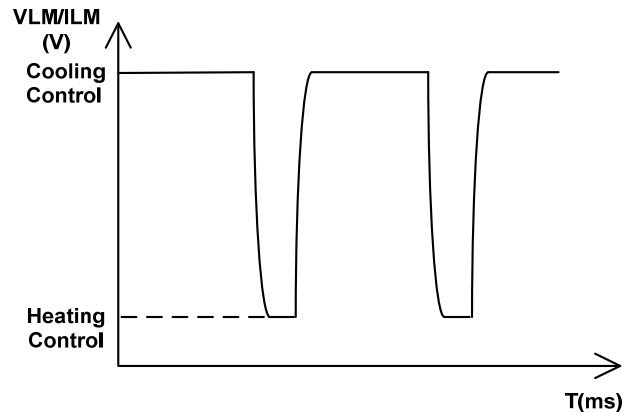

Figure 22. The Waveform on the VLM or ILM Pin @ SB State

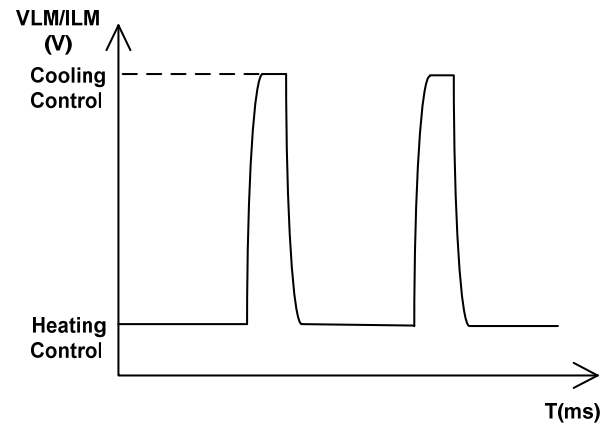

Figure 23. The Waveform on the VLM or ILM Pin @ Operation State

We can tell the VLM or ILM voltage in cooling control or heating control through the waveforms on the VLM or ILM pin, see Figure 22 and Figure 23. The duty cycle in Figure 22 is 99% and 1% in Figure 24. We can also measure both voltages by a multimeter. When the controller is in the Standby State, the voltage measured by the multimeter is the VLM or ILM voltage in cooling control. When the controller is in Operation State, the voltage measured by the multimeter is the VLM or ILM voltage in heating control.

Temperature-Network

TEC50V20ACH comes with a customized internal compensational network for which the component values are specified by the customer. See Figure 7.

TEC50V20ACH comes with a customized Temperature network. See Figure 7 and Figure 8.

The resistors and capacitors controlled by the dial switch are used to adjust the compensation network. The default values of resistors and capacitors are shown in Table 4



Table 4. Pin Function Descriptions

Parameter	Value	Note
R _P	10MΩ	
R _I	2MΩ	
R _D	24.9kΩ	
C _I	100nF	
C _D	1μF	

Table 5 is printed on the actual TEC50V20ACH, which shows the values of V_{SBDN}.

State	D1	D2	D3	V _{SBDN}	
ON=1 ↑	0	0	0	0V	OFF
	0	0	1	1.8V	SB
OFF=0 ↓	0	1	0	2.2V	IC
	1	0	0	2.6V	RTD
	1	1	1	3.6V	RTH

GETTING STARTED

Hook up the power supply, TEC and thermistor. There are 2 solder pads in the upper right area on the edge for connecting the DC power supply voltages. The connection can be done by clipping or soldering on the pads. Usually the power supply is set from 12V to 50V, a power supply of about having higher voltage than the maximum output voltage. There are also 2 solder pads in the upper right area on the edge for connecting the TEC terminals in the right polarity as indicated onto the board. Connect the thermistor terminals to the board, there is no polarity requirement. On the top of the board, there is the switch bank S1, which is used for adjusting D1, D2 and D3 to achieve different functions, in Table 5. At the same time, adjust the position of S2

1. Turn on and off the controller. This can be done by either turning off the power supply or turning off the shut-down pin of the controller. To do the latter, turn off the switch D1, D2, D3 in S1 to power off the controller.
2. Check the voltage reference. Use a voltmeter to check the voltage reference pin SNCO having an accurate 4.096V.

Tune the compensation network. The purpose for this step is to match the controller compensation network with the

with S1. There is an IC port on the bottom left of the edge for IC temperature sensor input. The switch of S3 is used to adjust the compensation network of temperature control loop by inputting a square wave disturbing signal in temperature input point, which enables the system to generate corresponding response waveform. At this time, observe the waveform change by oscilloscope, and adjust and optimize the compensation network of the temperature control loop so as to achieve the best waveform at the same time. Response waveform is achieved by measuring IDR with oscilloscope, as shown in Figure 24 and Figure 25. The compensation network components consist of R_I, R_D, R_P, C_D and C_I, which will be adjusted by S4, S5, S6, S7 and S8. These connections can be done by clipping or soldering on the pads. Check the evaluation board connections, making sure that they are all correctly connected.

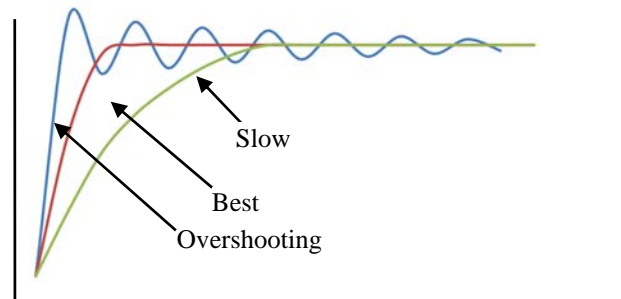

Figure 24. Rise Waveforms of IDR

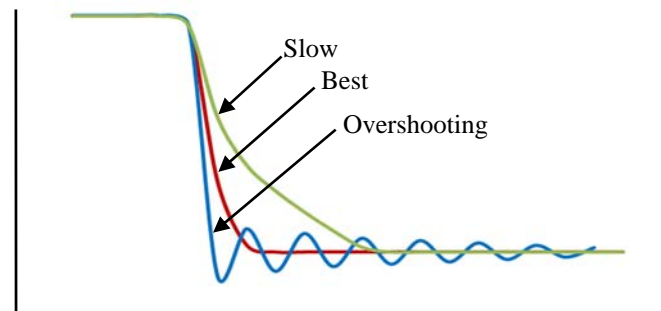

Figure 25. Fall Waveforms of IDR

thermal load characteristics thus that the response time and temperature tracking error are minimized. Adjust the potentiometer W1 to change the set-point temperature TMS just a small amount, simulating a step function, or press S3 to simulate a step function. At the same time, connect an oscilloscope at the IDR test pin (on the left side of the evaluation board), set it to a scrolling mode (0.2 Second/Division or slower) and monitor the waveform of IDR as TMS is fed by a step function signal. The circuit in the compensation network is shown in Figure 26 below.

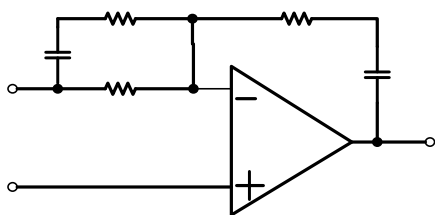

Figure 26. Compensation Network

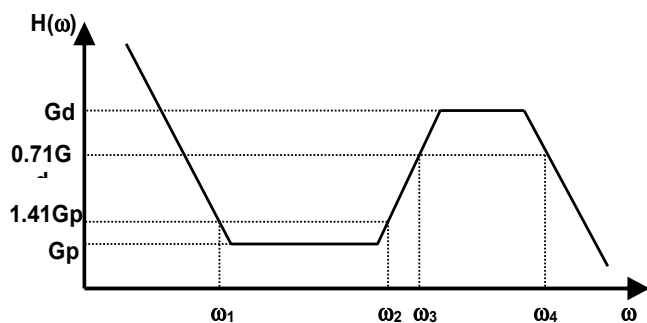

Figure 27. Transfer Function of the Compensation Network

The transfer function of the compensation network, defined as $H(\omega) = \text{IDR}(\omega) / \text{TMS}(\omega)$, is shown in Figure 27.

In principle, these are the impacts of the components to the tuning results:

- R_P/R_I determines the gain for the proportional component of the feedback signal which is from the thermistor, $G_p = R_P/R_I$, in the control loop, the higher the gain, the smaller the short term error in the target temperature (which is of the cold side of the TEC) compared with the set-point temperature, but the higher the tendency of the loop's instability.
- R_P/R_D determines the gain for the differential component, $G_d = R_P/(R_D//R_I) \approx R_P/R_D$, where symbol "//" stands for two resistors in parallel, since $R_I \gg R_D$, $R_D//R_I \approx R_D$. The higher the gain, the shorter the rise time of the response, the more the overshoot and/or the undershoot will be.
- $C_I \times R_P$ determines the corner frequency, $\omega_1 = 1/(C_I \times R_P)$, where the integral component starts picking up, as the frequency goes down. It determines the cut-off frequency below which the TEC controller will start having a large open loop gain. The higher the open loop gain, the smaller the tracking error will be.
- $C_D \times R_I$ determines the corner frequency, $\omega_2 = 1/(C_D \times R_I)$, where the differential component starts picking up (see Figure 27), as the frequency goes up.

- $C_D \times R_D$ determines the corner frequency, $\omega_3 = 1/(C_D \times R_D)$, where the differential component starts getting flat. It determines the cut-off frequency above which the TEC controller will give extra weight or gain in response.
- $1nF \times R_P$ determines the corner frequency, $\omega_4 = 1/(1nF \times R_P)$, where the differential component starts rolling down. Since this frequency is way higher than being needed for controlling the TEC, ω_4 does not need to be tuned. The capacitor is built into the TEC controller module, not the evaluation board.

To start the tuning, turn off the differential circuit by setting C_D Open. Turn $W1$ quickly by a small angle, back and forth, approximately 5 seconds per change. Set C_I to 1uF, set R_I to 1M, and increase the ratio of R_P/R_I as much as possible, provided the loop is stable, i.e. there are no oscillations seen in IDR. Then, minimize C_I as much as possible, provided the loop is stable. The next step is to minimize R_d and maximize C_D while maintaining about 10% overshoot found in IDR. Optimum result can be obtained after diligent and patient tuning. The tuning is fun and important.

When the TEC controller is used for driving a TEC to stabilize the temperature of a diode laser, there is no need to turn on the laser diode while tuning the TEC controller. To simulate the active thermal load given by the laser diode, setting the set-point temperature lower than the room temperature is enough.

For a typical laser head used in EDFA's or laser transmitters (found in DWDM applications, for instance), $R_I = 1M\Omega$, $R_P = 1M\Omega$, $C_I = 470nF$, $C_D = 2.2\mu F$, and $R_D = 200k\Omega$. These values may vary, depending on the characteristics of a particular thermal load.

To be conservative in stability, use larger C_I and larger R_I ; to have quicker response, use smaller R_d and larger C_D .

The closer to the TEC the thermistor is mounted, the easier to have the loop stabilized; the shorter the rise time, the settling time of the response will be.

- After tuning, the values of the capacitors for C_D and C_I can be read off the capacitor selection switches. The values of the resistors, R_I , R_d and R_P , can be measured by an Ohm-meter by connecting to the resistor pins. R_I can be read off between TMS and CMIN test points; R_D can be read off between CMIN and CDRD test points; R_P can be read off between CMIN and CIRP test points; C_D can be read off between TMS and CDRD test points; C_I can be read off between CIRP and IDR test points.
- After the compensation network is tuned properly, we can now adjust set-point temperature to see if the TEC controller can drive the target temperature to a certain

range and with high stability. Turn the temperature set-point TMS potentiometer W1 while monitoring its output voltage at TMS test point (2nd row on left side of the board), watch the LED: when it turns to green, the target temperature is locked to the set-point temperature within 0.1°C or less. The relationship between the set-point voltage vs. the set-point temperature is given in the datasheet. After seeing the LED lock into the set-point temperature, IDR should be a constant voltage as shown in the oscilloscope and the voltage between TMS and TMO should be very small, less than 10mV. When a standard TEC controller is used, the 10mV represent a 0.07° temperature error.

3. Set output voltage limit. Adjust the potentiometer W4 to set the voltage limit. TP VLIM is the test point for W4. After the VLM is tuned properly, adjust W5 to achieve different voltage limit for heating and cooling. TP VLIMO is the test point for W5. As is shown in Figure 28 and Figure 29.
4. Set output current limit. Adjust the potentiometer W2 to set the current limit. TP ILIM is the test point for W2. After the current limit is tuned properly, adjust W3 to achieve different ILM for heating and cooling. TP ILIMO is the test point for W3. As is shown in Figure 28 and Figure 29.

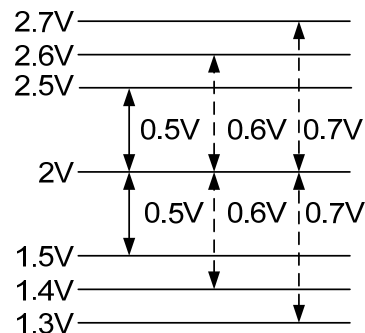

Figure 28. Adjust W2 or W4

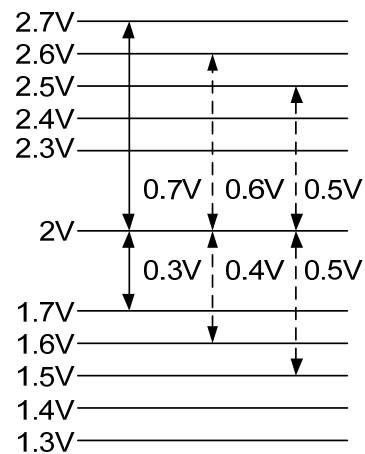

Figure 29. Adjust W3 or W5

TYPICAL CHARACTERISTICS

Table 6. Measurement Data of Rth vs. Temperature

Temp. (°C)	Rth (kΩ)	TMO (V)	Ideal Linear (V)	Error
15	15.7049	0.05	0.1	-0.05
16	14.9944	0.24	0.3	-0.06
17	14.3198	0.43	0.49	-0.06
18	13.6792	0.63	0.69	-0.06
19	13.0705	0.82	0.88	-0.06
20	12.4922	1.02	1.08	-0.06
21	11.9425	1.22	1.27	-0.05
22	11.4198	1.42	1.47	-0.05
23	10.9227	1.62	1.66	-0.04
24	10.4499	1.82	1.86	-0.04
25	10	2.03	2.05	-0.02

Temp. (°C)	Rth (kΩ)	TMO (V)	Ideal Linear (V)	Error
26	9.5718	2.23	2.25	-0.02
27	9.1642	2.44	2.44	0
28	8.776	2.64	2.64	0
29	8.4063	2.85	2.83	0.02
30	8.0541	3.05	3.03	0.02
31	7.7184	3.25	3.22	0.03
32	7.3985	3.46	3.42	0.04
33	7.0935	3.66	3.61	0.05
34	7.0935	3.86	3.81	0.05
35	6.5251	4.06	4.00	0.06

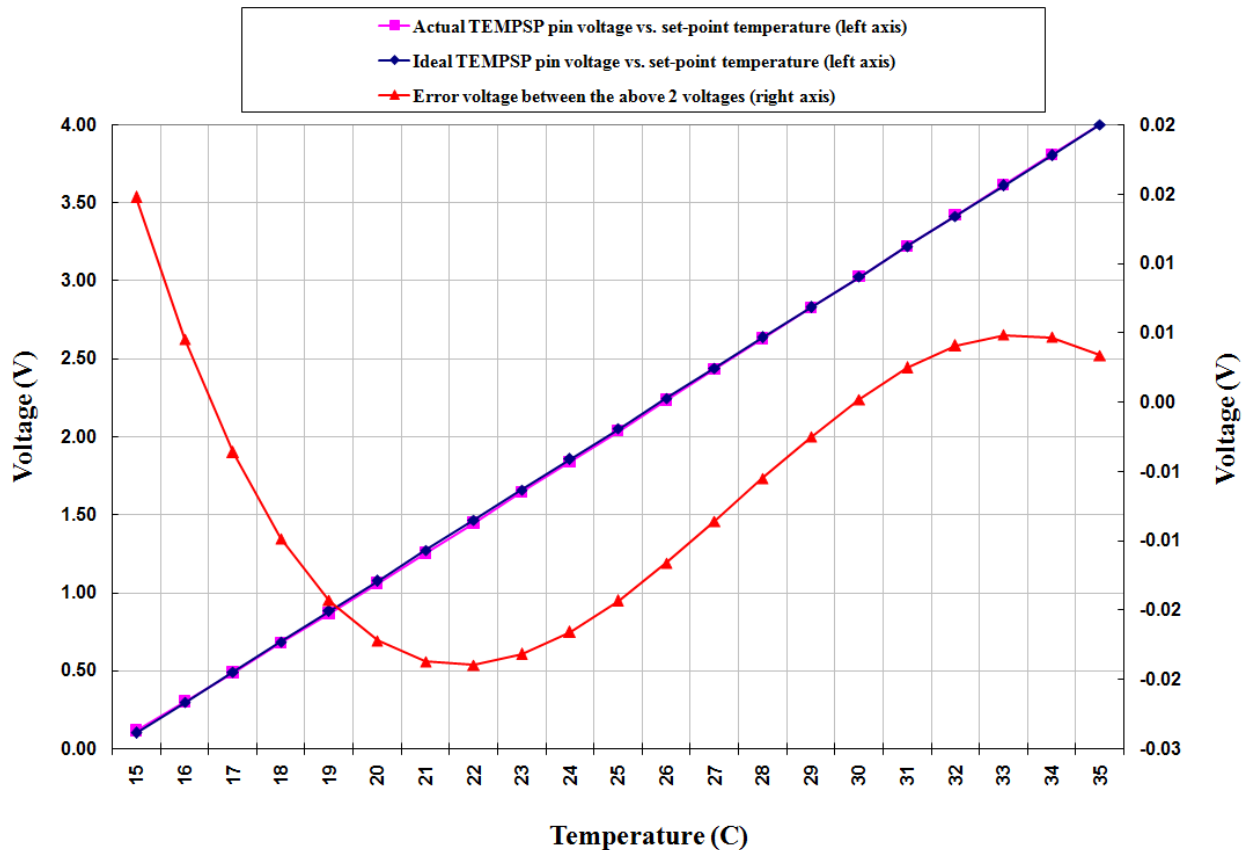

Figure 30. TMO Pin Voltage vs. Set-point Temperature

To know more parameters of the TEC controller:

a. To know the actual target temperature, use a voltage meter to measure the voltage between the TMO and the GND pins, the reading result is:

target temperature (°C) = $25^{\circ}\text{C} + V_{\text{TMO}} (\text{V}) \times 7.89^{\circ}\text{C}$ for approximation (see the curve in the TEC controller data sheet).

b. To know how hard the TEC is working, measure the voltage V_{TEC} by a voltage meter or an ADC,

$$V_{\text{TEC}} (\text{V}) = 25 \times V_{\text{VTEC}} (\text{V}) - 50\text{V}.$$

When the TEC voltage (from the calculation) is positive, it is in cooling mode; when the TEC voltage is negative, it is in heating mode.

c. To try other values of capacitors not provided by the evaluation board for the capacitors in the compensation network, turn down the capacitor switches, to the “OUT” position, connect the component to the corresponding soldering pads as marked on the evaluation board.

d. To shut down the TEC controller, turn the Shutdown

Control switch D1, D2, D3 in S1 to “Off”.

e. To control the set-point temperature directly by using a DAC, set the set-point temperature POT W1 to the middle point (25°C), on which the TMS is about 1.5V, the half value of the reference voltage, connect TMS test point to the output of the DAC and use this formula for approximation when the input voltage is between 0.1V and 3.9V:

set-point temperature (°C) = $25^{\circ}\text{C} + V_{\text{TMO}} (\text{V}) \times 7.89^{\circ}\text{C}$. The maximum voltage allowed is V_{VPS} (power supply). See the curve in the TEC controller data sheet.

f. To control the TEC voltage directly by using a DAC, connect V_{TEC} to the output of the DAC and use this formula: $V_{\text{TEC}} (\text{V}) = 25 \times V_{\text{VTEC}} (\text{V}) - 50\text{V}$.

g. To shut down the TEC controller by using a microprocessor, turn off the Shutdown Control switch, connect SBDN test point (3rd row from the left side, on top side of the board) to one of its digital outputs. When pulling low, the TEC controller is shut off. When pulling high SBDN, the TEC controller is turned on.

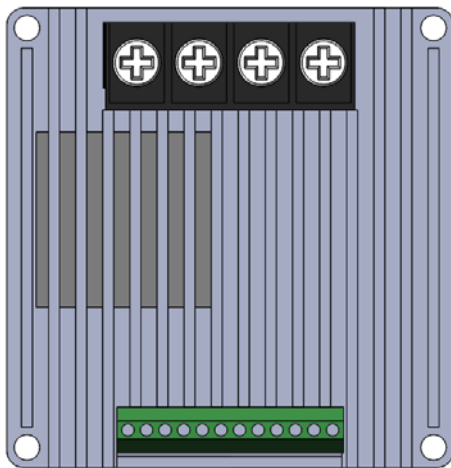

Figure 31. Top View of TEC50V20ACH

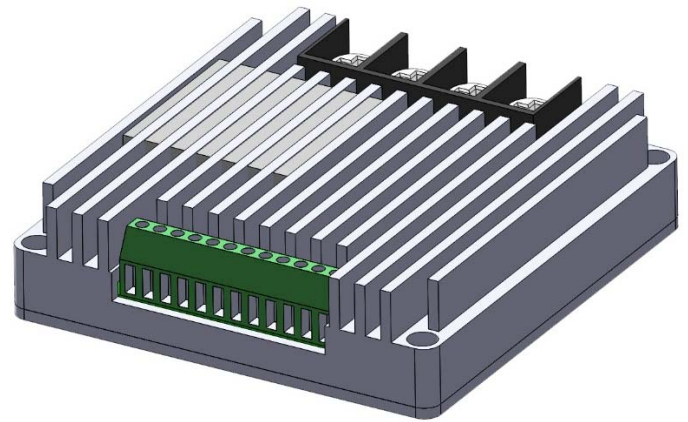

Figure 32. The 3D view of TEC50V20ACH

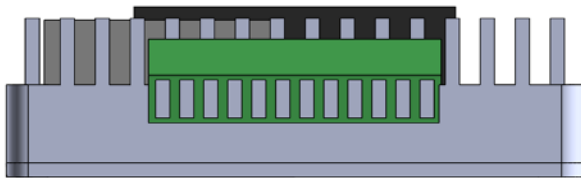

Figure 33. Side View



Figure 34. Side View

MECHANICAL DIMENSIONS

The controller comes in BLOCK package, with good heat dissipation performance, and can work under high power without adding heat sink. The part number: TEC50V20ACH. Dimensions of this controller is shown in Figure 31.

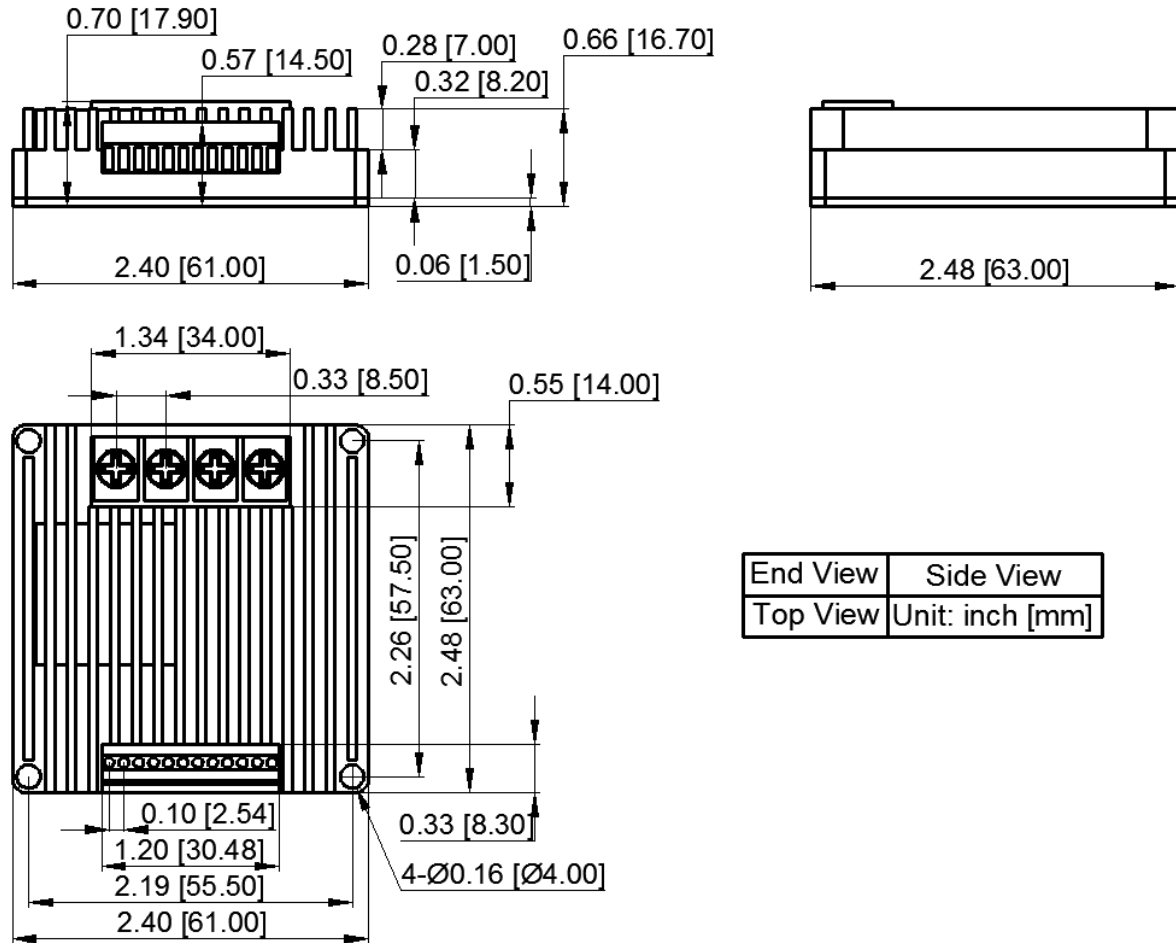

Figure 35. Dimensions of BLOCK Package

NOTICE

1. ATI warrants performance of its products for one year to the specifications applicable at the time of sale, except for those damaged by excessive abuse. Products found not meeting the specifications within one year from the date of sale can be exchanged free of charge.
2. ATI reserves the right to make changes to its products or to discontinue any product or service without notice and advise customers to obtain the latest version of relevant information to verify, before placing orders, that information being relied on is current and complete.
3. All products are sold subject to the terms and conditions of sale supplied at the time of order acknowledgment, including those pertaining to warranty, patent infringement, and limitation of liability. Testing and other quality control techniques are utilized to the extent ATI deems necessary to support this warranty. Specific testing of all parameters of each device is not necessarily performed, except those mandated by government requirements.
4. Customers are responsible for their applications using ATI components. In order to minimize risks associated with the customers' applications, adequate design and operating safeguards must be provided by the customers to minimize inherent or procedural hazards. ATI assumes no liability for applications assistance or customer product design.
5. ATI does not warrant or represent that any license, either expressed or implied, is granted under any patent right, copyright, mask work right, or other intellectual property right of ATI covering or relating to any combination, machine, or process in which such products or services might be or are used. ATI's publication of information regarding any third party's products or services does not constitute ATI's approval, warranty or endorsement thereof.
6. IP (Intellectual Property) Ownership: ATI retains the ownership of full rights for special technologies and/or techniques embedded in its products, the designs for mechanics, optics, plus all modifications, improvements, and inventions made by ATI for its products and/or projects.