

FEATURES

- High Efficiency: $\pm 90\%$
- Maximum Output Current: 2A
- No Heat Sink Required
- Current and Power Programming, Modulation & Monitoring Capabilities.
- Current Output Noise: 0.05%
- High Stability: 100ppm/ $^{\circ}\text{C}$
- Zero EMI
- Compact Size
- 100 % Lead (Pb)-free and RoHS Compliant
- DIP Package Available

APPLICATIONS

DPSSL, EDFA, and instrumentation diode lasers.

DESCRIPTION

The LDA1-CP2 is an electronic module designed for driving diode lasers (N type) with well controlled and monitored driving current and output laser power. Its PWM (Pulse Width Modulation) output stage achieves $\pm 90\%$ high power efficiency, eliminating the need for a heat sink. The output current and laser power can be set linearly by two separate input voltages and monitored linearly at the same time by two output voltages respectively. It comes with a high stability low noise 2.5V reference voltage which can be used for setting the output current and as voltage references for external ADCs and DACs.

The rise and fall time of this driver is about 15 μs .

LDA1-CP2 is packaged in a 6 sided metal enclosure, which blocks EMIs (Electro-Magnetic Interferences) to prevent the controller and other electronics from interfering each other.

The LDA1-CP2 physical photo is shown in Figure 1. Figure 2 is the actual size top view of the LDA1-CP2, which shows the pin names and locations. Its thickness is 4.6mm. The LDA1-CP2 pin functions are shown in table 1.

Table 1. Pin Function Descriptions

Pin #	Pin Name	Pin Type	Description
1	SDNG	Digital input	Shut down control. Negative logic, at the internal chip control input: $>2.3\text{V}$ = enable, $<0.5\text{V}$ = shut down, normal threshold voltage = 1.2V. Its internal circuit is shown in Figure 3 above. The diode is for shortening the shut down time.
2	CLPGD	Digital output	Control loop good indication. A HI level indicates control loop locked. This pin is an open drain output and pulled up by a 20K resistor to VPS.
3	P/CM	Analog output	Power/current mode indication. HI = power mode, LO = current mode. Low output impedance, capable of driving 20mA load.
4	GND	Signal ground	Signal ground pin. Connect ADC and DAC grounds to here.
5	2.5VREF	Analog output	Reference voltage. It is used by the internal DACs as the reference voltage. It can source

Warning: This module can only be soldered manually on the board by a solder iron at $< 310^{\circ}\text{C}$ (590°F), it cannot go through a reflow oven process.



Figure 1. Physical Photo

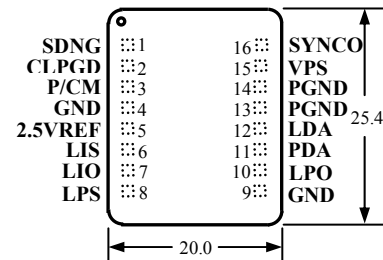

Figure 2. Pin Names and Locations

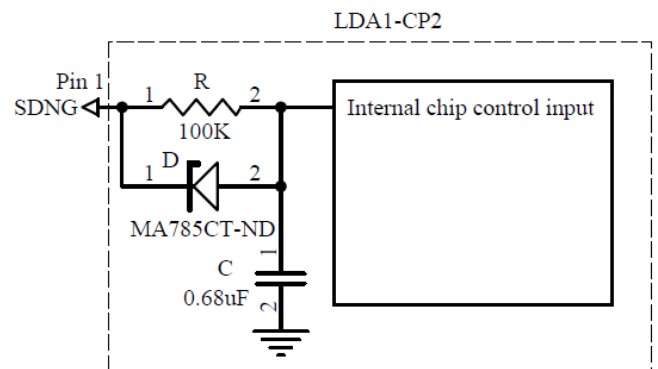

Figure 3. Internal Shut down Circuit



			3mA max, with 5mVp-p noise @ 0.1 to 10 Hz and 25ppm/ C stability max.
6	LIS	Analog input	Laser current set-point voltage. 0V to 2.5V sets the output current from 0 to 2A linearly. The input impedance of this pin is 100K Ω . This pin can be set by an external analog signal source, such as the output of a closed-looped op-amp, POT, or DAC.
7	LIO	Analog output	Laser current output indication. 0V to 2.5V indicates the laser current of from 0A to 2A linearly.
8	LPS	Analog input	Laser power set-point voltage. 0V to 2.5V sets the laser output power from 0 to the maximum value linearly. The input impedance of this pin is 100K Ω . This pin can be set by an external analog signal source, such as the output of a closed-looped op-amp, POT, or DAC.
9	GND	Signal ground	The same as Pin 4
10	LPO	Analog output	Laser power output voltage. Low impedance output. This is the output of the TIA (Trans-Impedance Amplifier) for the photodiode in the laser. The trans-impedance is set by an external resistor R1 between PDA (pin 11) pin and GND (pin 9). See the schematic in Figure 4 or Figure 5 below. Please note: $V_{LPO} = 2.5V - V_{PDA}$ ($V_{PDA} \leq 1V$).
11	PDA	Analog input	Photodiode anode. This is the negative input of the TIA. See Pin 10 description and Figure 4 or Figure 5 for the usage of this pin. If the PD's capacitance exceeds 10pF, put a capacitor of about the same value in parallel with R1 for compensation.
12	LDA	Analog output	Laser diode anode. Connect it to the anode of the laser diode. This pin is used to drive a laser of which the cathode is connected to the case and the case is connected to the ground. See Figure 4 or Figure 5.
13	PGND	Power ground	Power ground pin. Connect it directly to the laser's cathode which is also the case of the laser. See Figure 4 or Figure 5.
14	PGND	Power ground	Power ground pin. Connect it directly to power supply return rail.
15	VPS	Power input	Power supply voltage. The driver works from 3.0V to 5.5V.
16	SYNCO	Digital output	Synchronization output. This pin can be used to synchronize another switch mode driver such as for a TEC (Thermo-Electric Cooler) or a power supply so that the other drivers will not interfere with this laser driver. The switching frequency is set at 700 KHz. There is a 10K resistor between this pin and the switcher output. This pin can also be used to see the switcher's output voltage, see measure its duty cycle and magnitude.

SPECIFICATIONS

Table 2. Characteristics ($T_{ambient} = 25\text{ C}$)

Parameter	Value	Unit/Note
Maximum output current	2	A
Maximum output voltage on LDA	$0.9 \cdot V_{ps}$	V
Laser current and power indication voltage	0 ~ 2.5	V
Laser current indication absolute accuracy	-0.5%	-
Laser current set-point voltage	0 ~ 2.5	V
Laser power set-point voltage	0 ~ 2.5	V
Laser driver efficiency	+90%	-
Current output noise	0.05%	RMS@2A
Rise time of current mode	2	ms
Rise time of power mode	100	μ s
PWM frequency	500	KHz
Power supply input voltage	3.0 ~ 5.5	V
Output reference voltage	2.5	V

Operating temperature	0 ~ 85	C
-----------------------	--------	---

CALIBRATE THE TIA TRANS-IMPEDANCE

Since the relationship between the output current of the PD (Photo Diode) inside the laser and the output laser power varies greatly from different laser diodes, the trans-impedance of the TIA needs to be calibrated to match the laser diode's need.

The calibration procedure is as follows:

Read the laser diode datasheet carefully. According to the laser power needed, find the corresponding current at room temperature. Let's call it Normal Operating Current, NOC.

Set the laser driver to output 1.2 times the NOC (See the description about LIS (pin 6)). For example, if 200mA NOC is needed for outputting a desired laser power of 100mW, set the laser driver to output 240mA current, i.e., set

$$LIS = 2.5V \cdot 0.24A/2A = 0.3V.$$

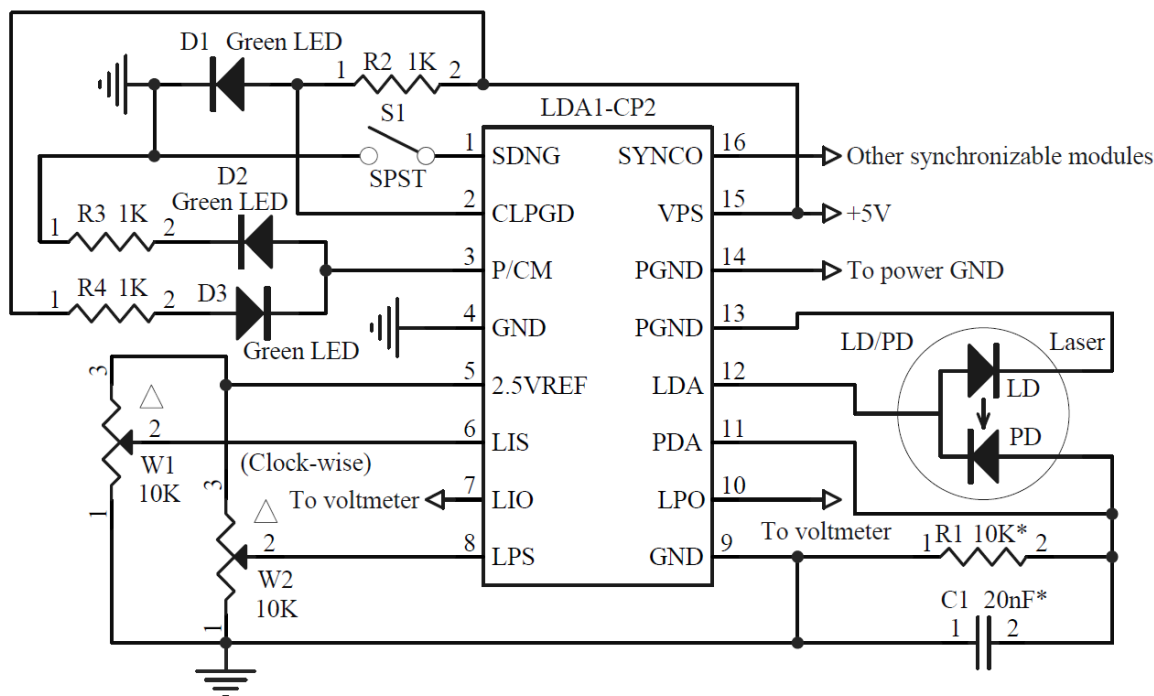

Figure 4. A Typical Self-contained Application Schematic

LDA1-CP2

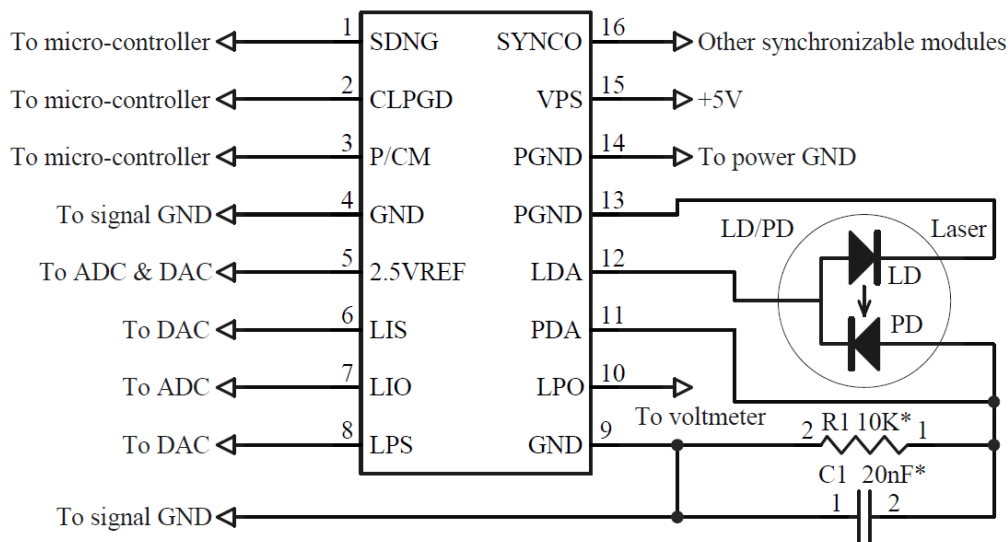

Figure 5. A Typical Micro-processor Based Application

Connect LPS to the 2.5V reference (pin 5), or turn the POT W2 all way up.

Place a main pole to stabilize the power control loop by adding the capacitor C1 in parallel with the resistor R1, see Figure 4 and 5. The relationship between R1 and C1 is:

$$\tau = R1 \cdot C1 = 200\mu s,$$

where, τ is constant, 200 μs . This pole needs to be of much lower in frequency than all the poles within the power control loop. The value of C1 is up to adjust R1 slowly till

the mode monitor pin is pulled up, indicating a constant power mode, and the LIO pin indicating the output current equals the normal operating current, i.e.:

$$LIO = 2.5V \cdot 0.2A/2A = 0.25V.$$

If you have an optical power meter, check the output power if see if it matches the desired the power. If not, adjust R1 till the output laser power equals the desired value. Measure of the output current after this step, set the protection current to 1.2 times of this current, i.e., set

$$LIS = 1.2 \cdot LIO$$



when the laser is outputting the desired power. The laser is now operating at a constant power mode. When the temperature changes for too much, after years' operation, or by some fault, the laser may be turned to current mode. Even at that time, the laser will at most be receiving 1.2 times the NOC, which will not damage the laser.

MODE SETTING

A. Set the driver to constant current mode without over power protection

In this mode, the laser is always operating at constant current mode.

1. Set

$$LIS = 2.5V \cdot I_{laser}/2.0A,$$

where I_{laser} is the set-point laser current.

2. Make sure that LPS is higher than LPO. This can be done by connecting LPS (pin 8) to the voltage reference 2.5V, pin 5, and PDA (pin 11) to LPO (pin 10).

B. Set the driver to constant current mode with over power protection

In this mode, the laser is operating at the constant current mode until the laser output power reaches the preset maximum power, the protection power, when this happens, the laser will be operating in a constant power mode.

1. Set

$$LIS = 2.5V \cdot I_{laser}/2.0A,$$

where I_{laser} is the set-point laser current.

2. Set LPS to the voltage generated at the LPO pin by the internal TIA when the laser is outputting the protection power level. The TIA converts the current of the power-sensing PD (Photo Diode) into a voltage, with the gain set by an external resistor connected between the PDA and GND pins. Make sure that the set-point laser current is at least 5%

less than the current needed to generate the protection laser power level.

C. Set the driver to constant power mode without over current protection

In this mode, the laser is always operating in the constant power mode (up to the maximum rated current of 2.0A).

1. Connect LIS to 2.5V reference pin.
2. Set LPS to the voltage value which is generated at the LPO pin by the internal TIA (Trans-Impedance Amplifier) when the laser is outputting the set-point power. The TIA converts the current of the power-sensing PD (Photo Diode) into a voltage, with the gain set by an external resistor connected between the PDA and GND pins. Make sure that the laser can output the set-point power by a current of less than 1.90A.

D. Set the driver to constant power mode with over current protection

In this mode, the laser is operating in the constant power mode unless the laser current reaches a predetermined protection current. When the laser reaches the protection current, the laser will be operating in constant current mode.

1. Set

$$LIS = 2.5V \cdot I_{protect}/2.0A,$$

where $I_{protect}$ is the predetermined protection current.

2. Set LPS to the voltage value which is generated at the LPO pin by the internal TIA (Trans-Impedance Amplifier) when the laser is outputting the set-point power. The TIA converts the current of the power-sensing PD (Photo Diode) into a voltage, with the gain set by an external resistor connected between the PDA and GND pins. Make sure that the laser can output the set-point power by a current of less than 95% of the protection current.

MECHANICAL DIMENSIONS

The driver comes in only one package: through hole mount. It is often called DIP (Dual In-line Package) or D (short for DIP) package and has a part number: LDA1-CP2-D. The through hole package can be mounted in a socket, soldered manually, or soldered through the wave soldering process.

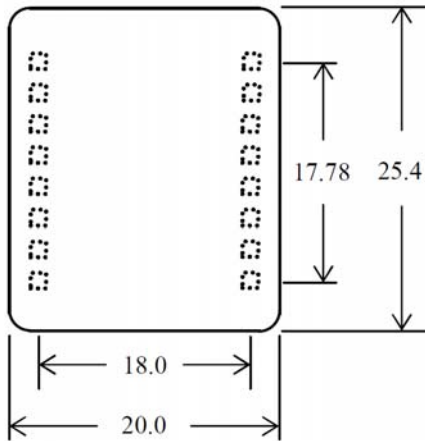

Figure 6. Top View of LDA1-CP2-D

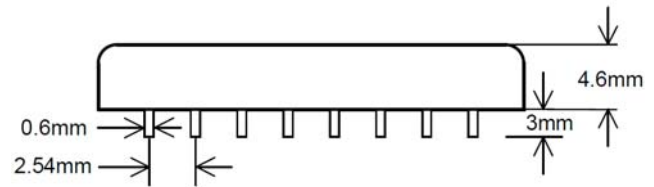

Figure 7. Side View of LDA1-CP2-D

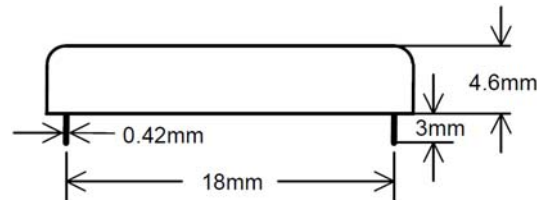

Figure 8. End View of LDA1-CP2-D

Figure 6 shows top view of LDA1-CP2-D, therefore, it is a “see through” view.

Figure 7 shows side view of LDA1-CP2-D.

Figure 8 shows end view of LDA1-CP2-D.

WARNING: This module can only be soldered manually on the board by a solder iron at $< 310^{\circ}\text{C}$ (590°F), it cannot go through a reflow oven process.

NOTE: The power supply may have overshoot, when happens, it may exceed the maximum allowed input voltage, 6V, of the controller and damage the controller permanently. To avoid this from happening, do the following:

1. Connect the controller solid well with the power supply before turning on the power.
2. Make sure that the power supply has sufficient output current. It is suggested that the power supply can supply 1.2 to 1.5 times the maximum current the controller requires.
3. When using a bench top power supply, set the current limit to >1.5 times higher than the maximum current the controller requires.

ORDERING INFORMATION

Table 3. Part Number

Part #	Description
LDA1-CP2-D	The 2A dual mode laser controller in DIP package is designed for driving N type diode lasers

Table 4. Prices

Quantity	1 ~ 9 PCs	10 ~ 49 PCs	50 ~ 199 PCs	200 ~ 499 PCs	≥ 500 PCs
LDA1-CP2-D	\$92.0	\$89.0	\$86.0	\$83.0	\$79.0

NOTICE

1. ATI warrants performance of its products for one year to the specifications applicable at the time of sale, except for those being damaged by excessive abuse. Products found not meeting the specifications within one year from the date of sale can be exchanged free of charge.
2. ATI reserves the right to make changes to its products or to discontinue any product or service without notice, and advise customers to obtain the latest version of relevant information to verify, before placing orders, that information being relied on is current and complete.



3. All products are sold subject to the terms and conditions of sale supplied at the time of order acknowledgment, including those pertaining to warranty, patent infringement, and limitation of liability. Testing and other quality control techniques are utilized to the extent ATI deems necessary to support this warranty. Specific testing of all parameters of each device is not necessarily performed, except those mandated by government requirements.
4. Customers are responsible for their applications using ATI components. In order to minimize risks associated with the customers' applications, adequate design and operating safeguards must be provided by the customers to minimize inherent or procedural hazards. ATI assumes no liability for applications assistance or customer product design.
5. ATI does not warrant or represent that any license, either express or implied, is granted under any patent right, copyright, mask work right, or other intellectual property right of ATI covering or relating to any combination, machine, or process in which such products or services might be or are used. ATI's publication of information regarding any third party's products or services does not constitute ATI's approval, warranty or endorsement thereof.
6. IP (Intellectual Property) Ownership: ATI retains the ownership of full rights for special technologies and/or techniques embedded in its products, the designs for mechanics, optics, plus all modifications, improvements, and inventions made by ATI for its products and/or projects.