



Figure 1. Top View ATMV24VPN100V125MA2



Figure 2. Side View



Figure 3. Side View



Figure 4. Bottom View

### FEATURES

- Wide Input Power Voltage Range: 20V to 36V
- Output Voltage:  $\pm 200V$
- Max. Output Current:  $\pm 62.5mA$
- High Efficiency: 82%  
@ $V_{IN} = 24V$  &  $V_{OUT} = \pm 200V$  &  $I_{OUT} = \pm 62.5mA$
- Output Ripple Voltage:  $\pm 1\%$  @20MHz
- Isolation Voltage: 1500VDC
- Output Short-Circuit Protection: Automatic Recovery
- Full Aluminum Housing for Complete Shielding
- Industry Standard DIP Package
- Operating Temperature Range:  $-40^{\circ}C \sim +85^{\circ}C$
- 100 % Lead (Pb)-free and RoHS Compliant

### APPLICATIONS

This power module, ATMV24V200V62R5MA2, is designed for achieving DC-DC conversion from low voltage to high voltage as a power supply source. It is widely used in scientific research and other fields including:

- Sustaining Ion Pumps
- Spectral Analysis
- Electrophoresis
- Particle Accelerator
- Capillary Electrophoresis
- Piezo Devices
- Photo Multiplier Tubes
- Avalanche Photo Diodes

### DESCRIPTION

This power module is a medium voltage, isolated DC–DC converter with 2:1 input voltage range. With a wide operating temperature range, built in short-circuit protection, providing this unit with high reliability and long life.

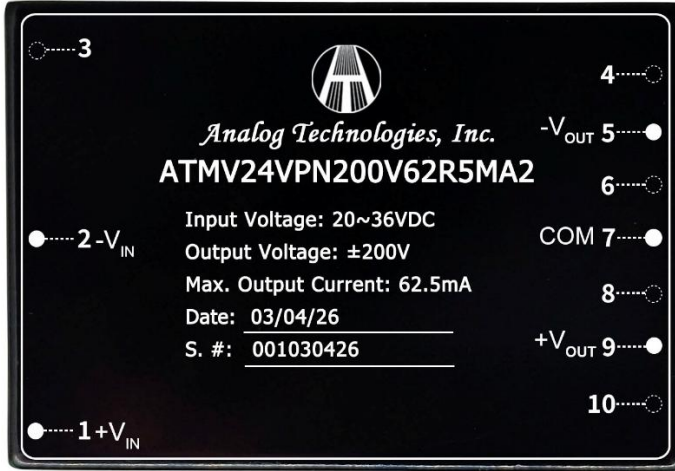

Figure 5. Top View

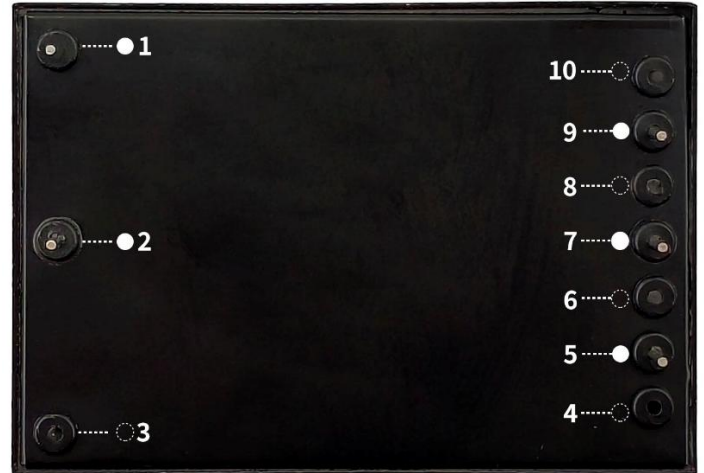

Figure 6. Bottom View

**Table 1. Pin Names, Functions and Specifications.**

| No. | Name              | Type   | Description             | Min. | Typ. | Max.  |
|-----|-------------------|--------|-------------------------|------|------|-------|
| 1   | V <sub>IN+</sub>  | Input  | Positive Input Voltage  | 20V  | 24V  | 36V   |
| 2   | V <sub>IN-</sub>  | Input  | Negative Input Voltage  |      | 0V   |       |
| 3   | NP                | -      | No Pin                  | -    | -    | -     |
| 4   | NP                | -      | No Pin                  | -    | -    | -     |
| 5   | V <sub>OUT-</sub> | Output | Negative Output Voltage |      |      | -200V |
| 6   | NP                | -      | No Pin                  | -    | -    | -     |
| 7   | COM               | -      | Serial port             | -    | -    | -     |
| 8   | NP                | -      | No Pin                  | -    | -    | -     |
| 9   | V <sub>OUT+</sub> | Output | Positive Output Voltage |      |      | +200V |
| 10  | NP                | -      | No Pin                  | -    | -    | -     |



**SPECIFICATIONS**

**Table 2.**

| Parameter  | Symbol                          | Test Conditions  | Min.                                | Typ.    | Max.  | Unit/Note     |
|--|---------------------------------|--|-------------------------------------|---------|-------|---------------|
| Input Voltage                                    | $V_{IN}$                        |  | 20                                  | 24      | 36    | V             |
| Input Quiescent Current                          | $I_{IN\_QC}$                    | $V_{IN} = 24V$<br>$I_{OUT} = 0mA$                        |                                     | 64      |       | mA            |
| Input Current                                    | $I_{IN}$                        | $I_{OUT} = 62.5mA$                                       |                                     | 1280    |       | mA            |
| Leakage Current                                  | $I_L$                           |  |                                     | 2       |       | mA            |
| Output Voltage                                   | $V_{OUT}$                       | $V_{IN} = 20V \sim 36V$<br>$I_{OUT} = -62.5 \sim 62.5mA$ | -200                                |         | +200  | V             |
| Output Voltage Accuracy                          |                                 | $V_{IN} = 20V \sim 36V$                                  |                                     | $\pm 2$ |       | %             |
| Output Current Range                             | $I_{OUTMAX}$                    | $V_{IN} = 20V \sim 36V$                                  | -62.5                               |         | +62.5 | mA            |
| Output Voltage Ripple                            | $V_{OUT\_RP}$                   | Bandwidth = 20MHz  |                                     | $\pm 1$ |       | %             |
| Output Short-Circuit Protection Time             | $t_{SC}$                        |  | Sustainable short-circuit operation |         |       |               |
| Switching Frequency                              | $f_{SW}$                        | $V_{VPS} = 24V$<br>Full Load                             |                                     | 125     |       | kHz           |
| Line Regulation                                  | $\Delta V_{OUT}/\Delta V_{VPS}$ | $V_{VPS} = 24V$<br>Full Load                             |                                     | $\pm 1$ |       | %             |
| Load Regulation                                  | $\Delta V_{OUT}/\Delta I_{OUT}$ | $V_{VPS} = 24V$<br>Load change from 10% to 100%          |                                     | $\pm 1$ |       | %             |
| Isolation Voltage                                | $V_{IS}$                        |  |                                     | 1500    |       | VDC           |
| Isolation Resistance                             |                                 | Input to Output, 500VDC,<br>$T_A = 25^\circ C, 70\%RH$   |                                     | 1000    |       | M $\Omega$    |
| Output Voltage Temperature Coefficient           | $TCV_{OUT}$                     | $V_{VPS} = 24V$<br>Full Load                             |                                     |         | 0.03  | %/ $^\circ C$ |
| Cooling Method                                   |                                 |  | Air Cooling                         |         |       |               |
| Mean Time Between Failure                        | MTBF                            | MIL-HDBK-217F@25 $^\circ C$                              |                                     | 1000    |       | Kh            |
| Operating Temperature Range                      | $T_{opr}$                       |  | -40                                 |         | 85    | $^\circ C$    |
| Storage Temperature Range                        | $T_{stg}$                       |  | -40                                 |         | 105   | $^\circ C$    |
| Maximum Soldering Temperature on Connection Pins | $T_{sld}$                       | Soldering Time:10s                                       |                                     |         | 300   | $^\circ C$    |
| Case Temperature Rise                            | $T_{CS}$                        | $V_{VPS} = 24V, T_A = 25^\circ C$<br>Full Load           |                                     | 35      |       | $^\circ C$    |
| Storage Relative Humidity Range                  | RH                              |  |                                     |         | 95    | %             |
| Case Material                                    |                                 |  | Aluminum                            |         |       |               |
| External Dimensions (Exclude Connection Pins)    |                                 |  | 72.00×40.00×24.00                   |         |       | mm            |
|  |                                 |  | 2.835×1.575×0.945                   |         |       | inch          |
| Weight   |                                 |  |                                     | 120     |       | g             |
|  |                                 |  |                                     | 0.110   |       | lbs           |
|  |                                 |  |                                     | 1.764   |       | Oz            |

## TYPICAL PERFORMANCE CHARACTERISTICS

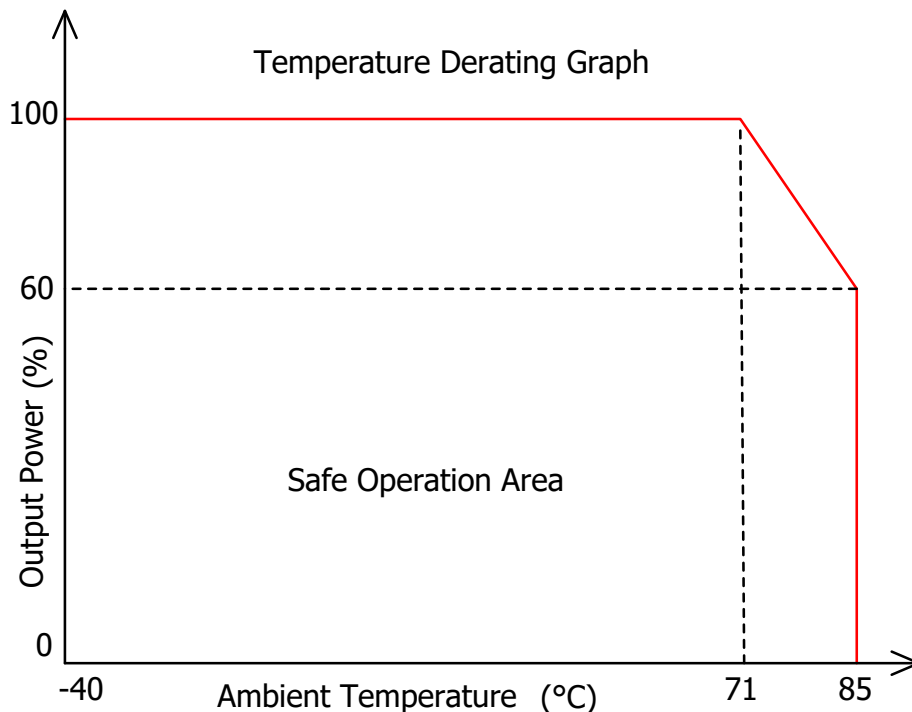

Figure 7. Derating Curve

## TYPICAL APPLICATIONS

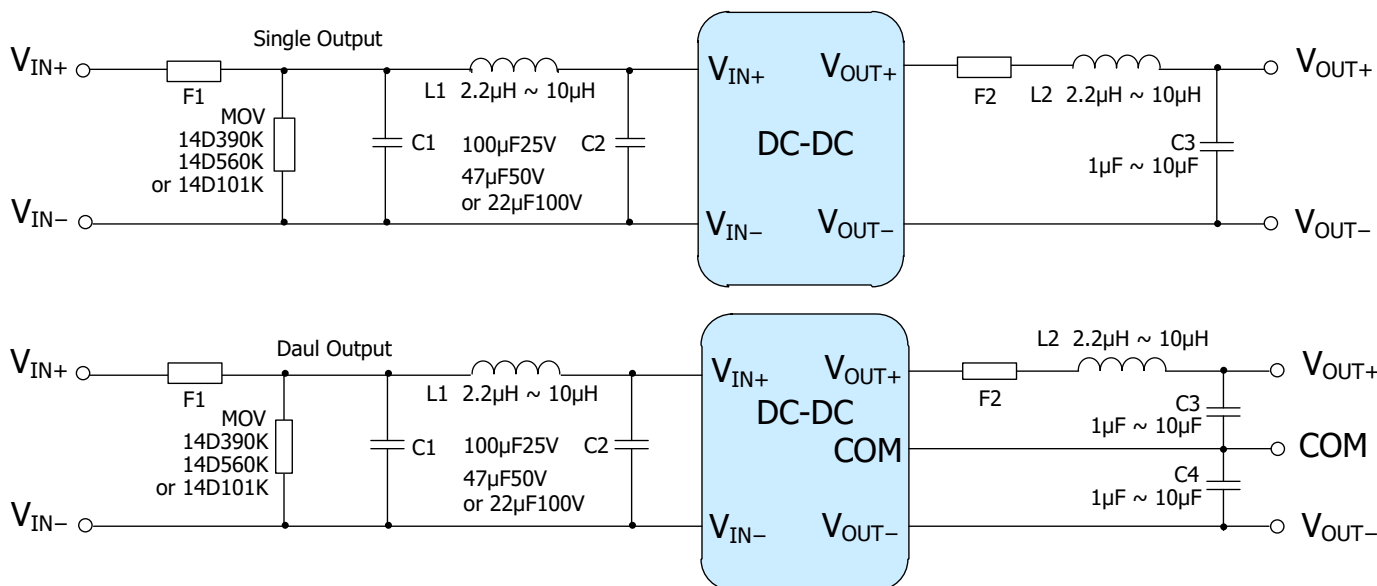

Figure 8. Typical Applications

**Table 3. Recommended Values**

|             |  |                      |
|-------------|--|----------------------|
| F1          | Input Time-delay Fuse                            |                      |
| F2 & F3     | Output Time-delay Fuse, or Resettable Fuse (PTC) |                      |
| MOV         | 14D390K  | Input Voltage: 12VDC |
|             | 14D560K  | Input Voltage: 24VDC |
|             | 14D101K  | Input Voltage: 48VDC |
| C1 & C2     | 100 $\mu$ F/25V                                  | Input Voltage: 2VDC  |
|             | 47 $\mu$ F/50V                                   | Input Voltage: 24VDC |
|             | 22 $\mu$ F/100V                                  | Input Voltage: 48VDC |
| C3 & C4     | 1.0 $\mu$ F ~ 10 $\mu$ F (High Frequency ESR)    |                      |
| L1, L2 & L3 | 2.2 $\mu$ H ~ 10 $\mu$ H                         |                      |

To further reduce the input and output ripple, the parameters of the LC filter can be appropriately increased, but it should be noted that the external capacitor at the output end should not be too large, and should be lower than the maximum capacitive load of the product.

## NAMING PRINCIPLE

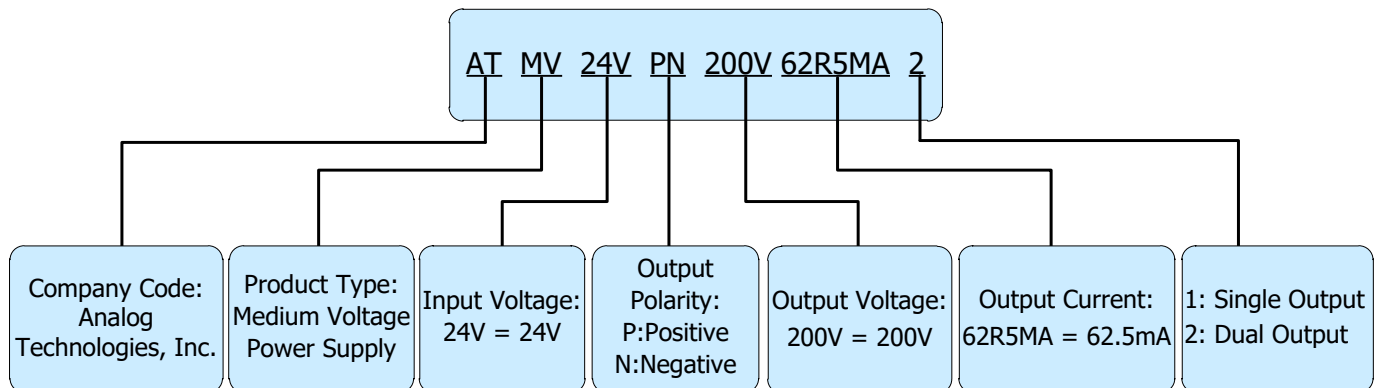
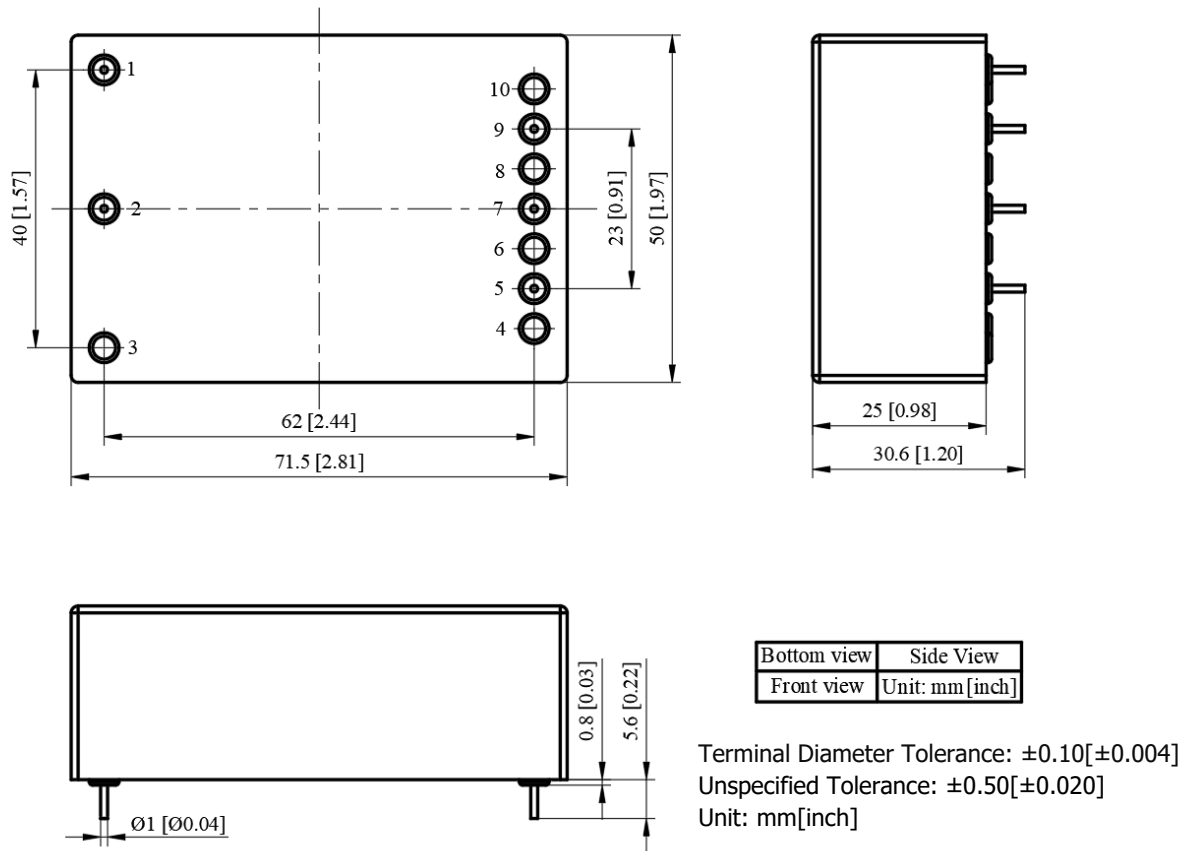



Figure 9. Naming Convention of ATMV24VPN200V62R5MA2

**OUTLINE DIMENSIONS**

| Pin            | 1         | 2         | 3  | 4  | 5          | 6  | 7   | 8  | 9          | 10 |
|----------------|-----------|-----------|----|----|------------|----|-----|----|------------|----|
| Single channel | $V_{IN+}$ | $V_{IN-}$ | NP | NP | $V_{OUT-}$ | NP | NP  | NP | $V_{OUT+}$ | NP |
| Dual channel   | $V_{IN+}$ | $V_{IN-}$ | NP | NP | $V_{OUT-}$ | NP | COM | NP | $V_{OUT+}$ | NP |

Figure 10. Outline Dimensions

**ORDERING INFORMATION**

| Part Number          | Buy Now   |
|----------------------|---|
| ATMV24VPN200V62R5MA2 |  *  * |



\*: both  and  are our online store icons. Our products can be ordered from either one of them with the same pricing and delivery time.



Table 4. ATMV24V200V62R5MA2 and Its Families

| Product Model     | Input Voltage |         | Output Voltage | Output Current | Efficiency | MAX. Capacitive Load |
|-------------------|---------------|---------|----------------|----------------|------------|----------------------|
|                   | Typ.          | Range   | V              | mA             | %          | µF                   |
| ATMV12V50V160MA1  | 12            | 9 ~ 18  | 50             | 160            | 78         | 100                  |
| ATMV12V100V80MA1  |               |         | 100            | 80             | 76         | 100                  |
| ATMV12V200V40MA1  |               |         | 200            | 40             | 75         | 68                   |
| ATMV12V300V20MA1  |               |         | 300            | 20             | 74         | 47                   |
| ATMV12V400V10MA1  |               |         | 400            | 10             | 73         | 33                   |
| ATMV12V500V8MA1   |               |         | 500            | 8              | 72         | 22                   |
| ATMV12V600V6.7MA1 |               |         | 600            | 6.7            | 70         | 10                   |
| ATMV12V700V4.3MA1 |               |         | 700            | 4.3            | 68         | 4.7                  |
| ATMV24V50V160MA1  | 24            | 18 ~ 36 | 100            | 80             | 78         | 100                  |
| ATMV24V200V40MA1  |               |         | 200            | 40             | 77         | 68                   |
| ATMV24V300V20MA1  |               |         | 300            | 20             | 75         | 47                   |
| ATMV24V400V10MA1  |               |         | 400            | 10             | 74         | 33                   |
| ATMV24V500V8MA1   |               |         | 500            | 8              | 73         | 22                   |
| ATMV24V600V6.7MA1 |               |         | 600            | 6.7            | 71         | 10                   |
| ATMV24V700V4.3MA1 |               |         | 700            | 4.3            | 70         | 4.7                  |
| ATMV12V50V80MA2   | 12            | 9 ~ 18  | ±50            | ±80            | 76         | 68                   |
| ATMV12V100V40MA2  |               |         | ±100           | ±40            | 75         | 68                   |
| ATMV12V150V20MA2  |               |         | ±150           | ±20            | 74         | 47                   |
| ATMV12V200V10MA2  |               |         | ±200           | ±10            | 73         | 33                   |
| ATMV12V250V8MA2   |               |         | ±250           | ±8.0           | 72         | 22                   |
| ATMV12V300V6.6MA2 |               |         | ±300           | ±6.6           | 70         | 10                   |
| ATMV24V50V80MA2   | 24            | 18 ~ 36 | ±50            | ±80            | 78         | 68                   |
| ATMV24V100V40MA2  |               |         | ±100           | ±40            | 77         | 68                   |
| ATMV24V150V20MA2  |               |         | ±150           | ±20            | 75         | 47                   |
| ATMV24V200V10MA2  |               |         | ±200           | ±10            | 74         | 33                   |
| ATMV24V250V8MA2   |               |         | ±250           | ±8.0           | 73         | 22                   |
| ATMV24V300V6.6MA2 |               |         | ±300           | ±6.6           | 71         | 10                   |



## NOTICE

1. ATI warrants performance of its products for one year to the specifications applicable at the time of sale, except for those being damaged by excessive abuse. Products found not meeting the specifications within one year from the date of sale can be exchanged free of charge.
2. ATI reserves the right to make changes to its products or to discontinue any product or service without notice, and advise customers to obtain the latest version of relevant information to verify, before placing orders, that the information being relied on is current and complete.
3. All products are sold subject to the terms and conditions of sale supplied at the time of order acknowledgment, including those pertaining to warranty, patent infringement, and limitation of liability. Testing and other quality control techniques are utilized to the extent ATI deems necessary to support this warranty. Specific testing of all parameters of each device is not necessarily performed, except those mandated by government requirements.
4. Customers are responsible for their applications using ATI products. In order to minimize risks associated with the customers' applications, adequate design and operating safeguards must be provided by the customers to minimize inherent or procedural hazards. ATI assumes no liability for applications assistance or customer product design.
5. ATI does not warrant or represent that any license, either express or implied, is granted under any patent right, copyright, mask work right, or other intellectual property right of ATI covering or relating to any combination, machine, or process in which such products or services might be or are used. ATI's publication of information regarding any third party's products or services does not constitute ATI's approval, warranty or endorsement thereof.
6. IP (Intellectual Property) Ownership: ATI retains the ownership of full rights for special technologies and/or techniques embedded in its products, the designs for mechanics, optics, plus all modifications, improvements, and inventions made by ATI for its products and/or projects.