



Figure 1. Physical Photo of ATLS5A212D

FEATURES

- Power Supply Voltage VPS Range: 4.5V ~15V
- Full Swing Output Voltage: **0.2V_{VPS} to 0.8V_{VPS}** (input voltage)
- Maximum Output Current: 5A
- High Efficiency: $\geq 90\%$ - no heat sink is needed
- ($I_{OUT}=5A @ V_{LDA}=11V \& V_{VPS}=15V$)
- Wide Modulation Bandwidth: DC ~ 10kHz
- Dual Independent Current Set Ports
- Direct Digital Modulation Control
- Three Control States: Shutdown, Standby and Operation
- Low Output Current Noise: $< 5.21 \mu A_{P-P} @ 0.1Hz \sim 10Hz$
- High Current Stability: $< \pm 300 \mu A @ 5A \& -20^{\circ}C \sim 80^{\circ}C$
- Low Output Ripple Voltage: $< 4mV @ 500kHz$
- Fully Shielded
- Compact Size: 25.4×20×5 (mm)
- 100 % Lead (Pb)-free and RoHS Compliant

APPLICATIONS

Driver for one or multiple laser diodes for DPSSL, EDFA, or fiber lasers with low noise and high efficiency.

DESCRIPTION

This laser driver, ATLS5A212, is an electronic module that has all the valuable and important, but often contradict features, simultaneously: Wide input and output voltage range, high output current capability, high efficiency, low

output noise (but it has a 4mV_{P-P} ripple voltage at 500kHz), wide modulation bandwidth, and small size. The wide output voltage range, 0.2V_{VPS} to 0.8V_{VPS}, allows driving one or multiple serial laser diodes at the same time, for up to 5A well controlled current at high efficiency. The extremely low noise between DC ~10kHz and low DC current drift make it ideal for driving diode pumped single mode laser diodes to achieve mode-hop-free and narrow optical wavelength drift, thus, long coherent length. Because of the high efficiency, the laser driver generates small amount of heat, thus, no heat sink is necessary for normal operation. The fully shielded case blocks all the incoming and outgoing EMIs (Electro-Magnet Interferences). Therefore, this laser will not interfere with other surrounding electronics, nor will be interfered by them. The small package saves valuable PCB space in laser systems. Figure 1 shows physical photo of the ATLS5A212.

This laser driver has two current set ports digitally controlled to switch between them for setting the output current. This feature allows modulating the laser digitally with 2 preset current values.

The actual laser current and laser driver temperature are monitored by dedicated ports. In case the laser driver temperature exceeds the limit, 120°C, the laser driver will shut down the output stage by itself and force the laser drive into Standby Mode. There is a loop good indication output to tell if the laser driver works ok.

The laser driver has 3 states: Operation, Standby and Shutdown. Under Standby mode, all the laser driver components work except the output stage, see Figure 4. Under Shutdown mode, all the components of the laser driver stop working and the power supply current is reduced to $< 3 \mu A$.

This laser driver generates a high accuracy high stability low noise, 5 μV_{P-P} , 3 μV_{RMS} , $< 8ppm/^{\circ}C$, 2.5V $\pm 2mV$, voltage reference output which can be used for setting the output current and also be used as the reference voltage for the ADCs (Analog to Digital Converters) and/or DACs (Digital to Analog Converters).

The ATLS5A212 uses a constant frequency high efficiency PWM output stage. Its switching signal is taken out through a buffer at the SYNO port, pin 14, which can be used by other switch mode electronics as the trigger signal to avoid frequency beating interference, if the free-run frequency is near to 500kHz.

Warning:

1. The output voltage must be within 20% to 80% of VPS.
2. Both the surface mount and the through hole types of packages can only be soldered manually on the board by a solder iron of $< 310^{\circ}C$ (590°F), do not use a reflow oven to solder this laser driver.



For noise sensitive applications, please be aware that this laser driver has very low noise between DC to 10kHz, but a little high ripple output voltage, sine-wave, 4mV_{P-P}, at the switching frequency, 500kHz.

Figure 2 is the top view of the ATLS5A212, which also shows the pin names and locations. Its thickness is 4.5mm. The pin functions and specifications are described in Table 1 below.

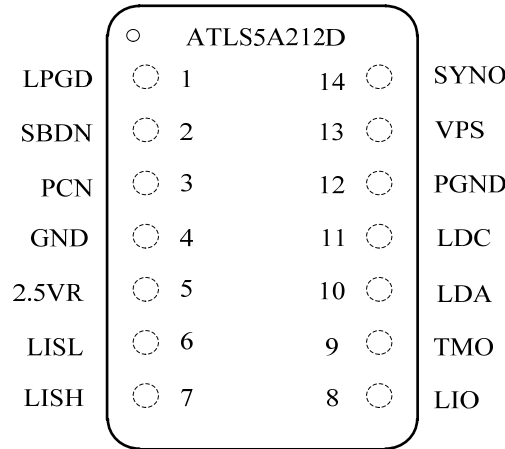

Figure 2. Pin Names and Locations

Table 1. Pin Function Descriptions

Pin #	Name	Type	Description
1	LPGD	Digital Output	Loop Good indication. When the laser driver's output current equals to the set-point current value, and there is no short nor open circuit at the output, this pin is pulled up high by an internal 3kΩ resistor to an internal 4V power supply as shown in Figure 3; when the output current is not equal to the set-point current, such as there is an open circuit at the output, or the load has too high a resistance that even the output voltage reaches the power supply voltage, the output current is still lower than the set-point value, this pin is pulled low by an open drain MOSFET of which R _{dson} < 500Ω. When outputting the low value, the sinking capability is < 0.5V at 1mA.
2	SBDN	Analog/Digital Input	Standby and Shutdown Control. This pin has 3 states: between 0V ~ 0.4V, it shuts down the entire laser driver; between 2.1V ~ 2.4V, it sets the laser driver to standby mode; between 2.6V ~ 15V, it sets the laser driver to operation mode. The input current on this pin is < 2μA.
3	PCN	Digital Input	Pulse Control input. This pin toggles the laser output current to change between two pre-set values: a low value set by the LISL pin @ PCN = 0V ~ 0.4V and a high value set by the LISH pin @ PCN = 1.4V ~ 4V. This PCN pin is pulled high to an internal 4V rail by a 1MΩ resistor and there is a serial 20kΩ resistor between PCN and the electronic switch, see Figure 3. Between 0V ~ 4V, the pull up resistor causes most of the current on this pin, the electronic switch input current is < ±1μA. The maximum voltage on this pin is 16V, at which the pull down current will be caused by the serial 20kΩ clamped by an over voltage protector of 5V, the current will be (16V - 5V)/20kΩ = 110μA. The rise and fall time of the output is 28μs when PCN pin is switched.
4	GND	Signal Ground	Signal Ground pin. Connect ADC and DAC grounds here. When using POTs (potentiometer) to set the output currents, connect the ground terminal of the POTs here. See Figure 7.



5	2.5VR	Analog Output	Voltage Reference, 2.5V, output. It can source and sink up to 10mA output current, with a very low $5\mu\text{V}_{\text{P-P}}$ noise between 0.1Hz to 10Hz and 6ppm/°C stability. Under Standby Mode, this pin is still working.
6	LISL	Analog Input	Laser current low value setting voltage. There is a $10\text{M}\Omega$ input resistor tied to GND. Setting it from 0V to 2.5V will set the laser lower current from 0 to 5A linearly. The current set by this pin can be higher than the current set by the LISH port on pin 7, the reason calling it "low" is because when PCN, pin 3, is low, the laser driver will output the current set by this pin. The input bias current of this pin is $< 0.1\mu\text{A}$, in addition to the $10\text{M}\Omega$ resistor tied to GND. The maximum input voltage on this pin is 4V. It is recommended to use the 2.5VR port, pin 5, as the voltage source for setting the output current.
7	LISH	Analog Input	Laser current high value setting voltage. For this pin, everything is the same as above except that this pin sets the output current when PCN, pin 3 is high.
8	LIO	Analog Output	Laser Current Output indication. 0V to 2.5V indicates the laser current being from 0 to 5A linearly.
9	TMO	Analog Output	Temperature Output pin. This pin indicates the controller temperature. The relationship between the output voltage and the temperature is: $2.55\text{V} (-40^\circ\text{C}) \sim 1.2\text{V} (85^\circ\text{C})$.
10	LDA	Analog Output	Laser Diode Anode. Connect it to the laser diode anode terminal. The maximum current of this pin can go up to 5A. When designing layout, do not use a thin and long PCB track, otherwise, the inductance might be too high and oscillation may occur.
11	LDC	Analog Output	Laser Diode Cathode. Connect it to the laser diode cathode terminal. The current on this pin can go up to 5A. Use thick and short PCB track for this pin to minimize the inductance to avoid oscillation or ringing. This pin has a low voltage potential, when the output current is 5A, the potential is 75mV above PGND.
12	PGND	Power Ground	Power ground pin. Connect this pin directly to power supply return path line, 0V. The maximum current on this pin can go up to 5A.
13	VPS	Power Input	Power supply voltage. The driver works from $V_{\text{VPS}} = 4.5\text{V} \sim 15\text{V}$. The maximum current can go up to 5A.
14	SYNO	Digital Output	Synchronization Output. This is a digital output signal with internal impedance of 100Ω by passed by 1.5MHz low pass filter. This output is triggered by the PWM output stage of this laser driver and can be used to synchronize other switch mode electronics to avoid the beating interference with their free-run frequencies if their free-run frequencies are close to 500kHz. If the free-run frequency of the other electronics is far away from 500kHz, this pin may be left unconnected.

SPECIFICATIONS

Table 2. Characteristics ($T_{\text{Ambient}} = 25^\circ\text{C}$)

Parameter	Value	Unit
Power efficiency $I_{\text{OUT}} = 5\text{A}$, $V_{\text{LDA}} = 8\text{V}$ & $V_{\text{VPS}} = 15\text{V}$.	90	%
Maximum output current	3	A
Low frequency output current noise peak-to-peak value, 0.1Hz to 10Hz $V_{\text{VPS}} = 12\text{V}$, $V_{\text{OUT}} = 6\text{V}$	5.21	$\mu\text{A}_{\text{P-P}}$
Stability @ 5A & $-20^\circ\text{C} \sim 80^\circ\text{C}$	$< \pm 0.01$	%
	$< \pm 300$	μA



Laser current control signal at LISL and LISH	0~2.5	V
LISL and LISH control accuracy	±0.1	%
Laser current indication signal at LIO	0~2.5	V
LIO indication accuracy	±0.2	%
Reference output voltage	2.5±0.004	V
Output voltage range at LDA	0.2V _{VPS} ~ 0.8V _{VPS}	V
Output voltage at LDC	0.025×I _{OUT}	V
Power supply voltage range	4.5~15	V
Maximum power supply voltage	16	V
Start-up time upon releasing the SBDN pin above 2.6V	20	ms
Shutdown time upon pulling the SBDN pin down	20	μs
Standby current	8	mA
Shutdown current	<2	μA
Operating case temperature	-40 ~ 110	°C
Operating ambient temperature	-40 ~ 85	°C

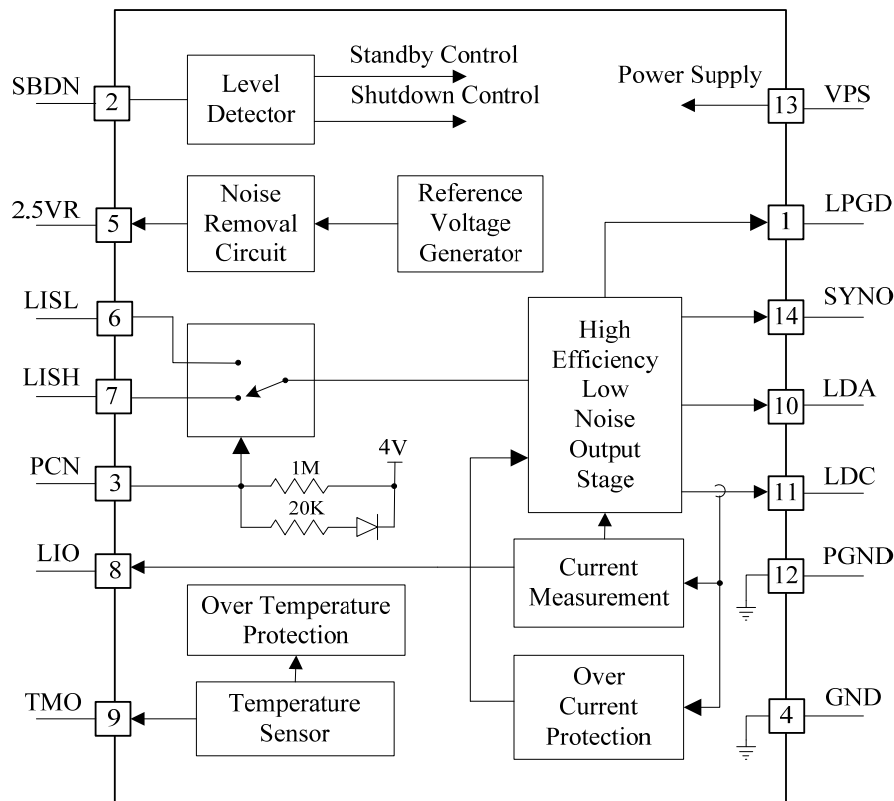

Figure 3. Internal Block Diagram of ATLS5A212



OPERATION PRINCIPLE

The block diagram of the driver is shown in Figure 3. The signal from pin 2, SBDN, is sent to a level detector circuit. As shown in Figure 4, upon detecting signal level between 0V to 0.4V, the shutdown output is activated, it shuts down the whole laser driver and drive the laser driver into Shutdown Mode; upon detecting the level to be between 2.1V and 2.4V, the standby signal is activated, it puts the controller into Standby Mode; when the signal is between 2.6V and above, the controller is driven to Operation Mode.

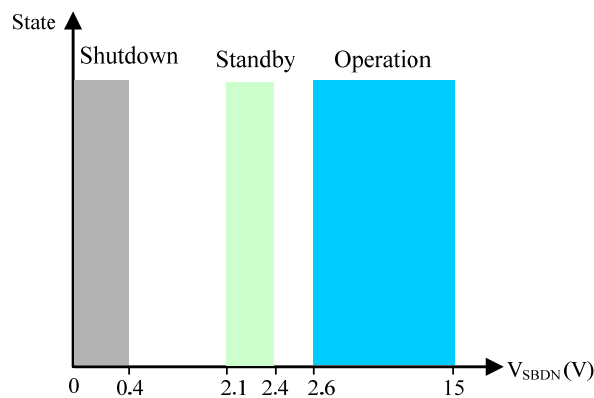

Figure 4. Input Control

At pin 9, TMO, its value comes from a temperature sensor. The voltage at this pin reflects the internal temperature of this driver. The relationship between the output voltage and the temperature is shown in Figure 5.

There is a temperature protection circuit, upon detecting the temperature to be >120°C, it will force the laser driver into Standby Mode. The laser driver reinitiates the power up sequence when the junction temperature drops below 110°C.

The voltage reference circuit provides internal voltage reference for the driver, its output is taken out after a noise removal circuit at 2.5VR port, pin 5.

At pin 6 and pin 7, there are 2 ports for controlling the output current: LISL and LISH. First one sets the output current when PCN, Pulse Control, pin 3, is at low level, 0V to 0.4V; second sets the output current when PCN pin is at high level, 1.4V to 4V.

On PCN, pin 3, there is a 10M resistor tied to 4V. Therefore, if leaving this pin open, it is set to 4V, a high logic level,

thus, LISH is in control. There is a 20kΩ resistor in series with a diode, connected between PCN pin and the 4V internal voltage. When the PCN pin voltage is above 4V, the 20k resistor pulls down the current on PCN pin. The circuit is shown at Figure 3. The waveforms of LISH, LISL, PCN and LIO are shown in Figure 6.

Both LISH and LISL pin set the output current without any offset voltage, i.e., when LISH or LISL pin voltage is 0V, it sets the output current to be 0A; when the LISH or LISL voltage is 2.5V, it sets the output current is 1A. The relationship between the voltage and the output current is:

$$I_{OUT} (A) = V_{LISH} (V) / 2.5 (V) \times 3 (A), \text{ or}$$

$$I_{OUT} (A) = V_{LISL} (V) / 2.5 (V) \times 3 (A);$$

$$V_{LISH} (V) = I_{OUT} (A) / 3 (A) \times 2.5 (V), \text{ or}$$

$$V_{LISL} (V) = I_{OUT} (A) / 3 (A) \times 2.5 (V),$$

Where I_{OUT} is the output current of the laser driver, V_{LISH} or V_{LISL} represents the voltage on the LISH or LISL pin respectively, in Volts.

The LIO port, pin 8, outputs an analog voltage that is proportional to the actual output current. When the output current is 0A, the LIO voltage is 0V; when output current is 5A, the LIO voltage is 2.5V. The relationship is:

$$V_{LIO} (V) = I_{OUT} (A) / 3 (A) \times 2.5 (V);$$

$$I_{OUT} (A) = V_{LIO} (V) / 2.5 (V) \times 3 (A);$$

where V_{LIO} is the voltage on the LIO pin.

The waveforms of LIO vs. LISH, LISL and PCN are shown in Figure 6.

The output stage is designed to achieve low noise, high efficiency, and relatively high modulation speed. It has an over current protection circuit. There is a soft start circuit which increases the output current slowly at the start up time and shuts down the current quickly.

The LPGD pin indicates the control loop status. When this pin goes high, >2V, the control loop is working properly, i.e., the output current equals to the desired value, V_{LISH} or $V_{LISL} = V_{LIO}$; when this pin goes low, <0.3V, the laser driver is not working properly, there might be a short or open circuit at the output, or the laser driver is protected by the over temperature protection circuit.

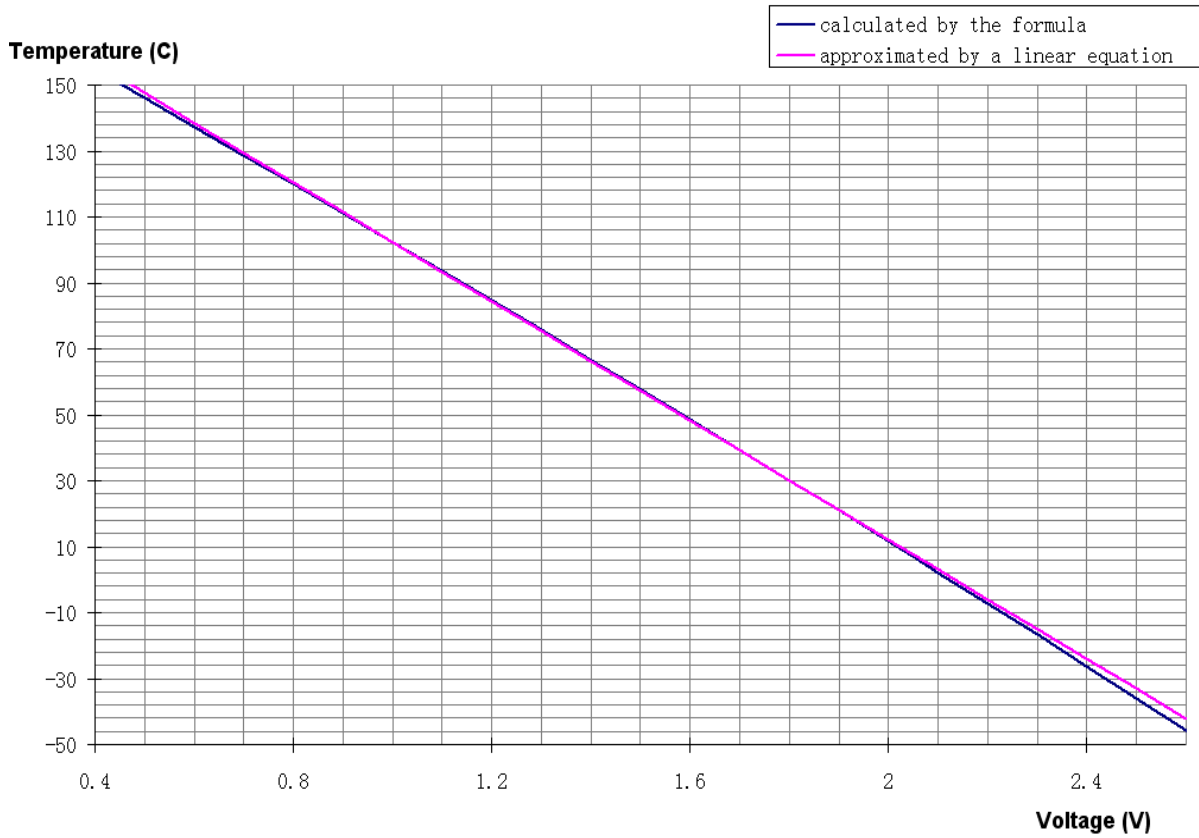

Figure 5. Controller Internal Temperature vs. TMPO Voltage

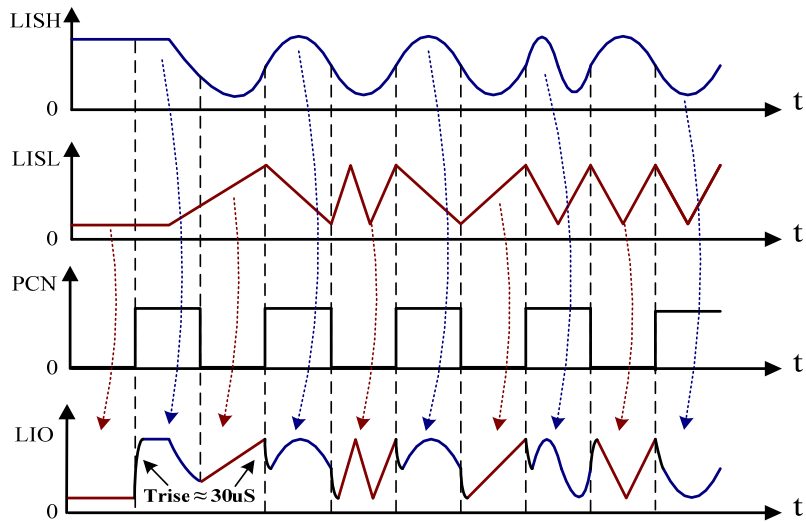

Figure 6. Digitally Controlled Analog Modulation Principle



APPLICATION INFORMATION

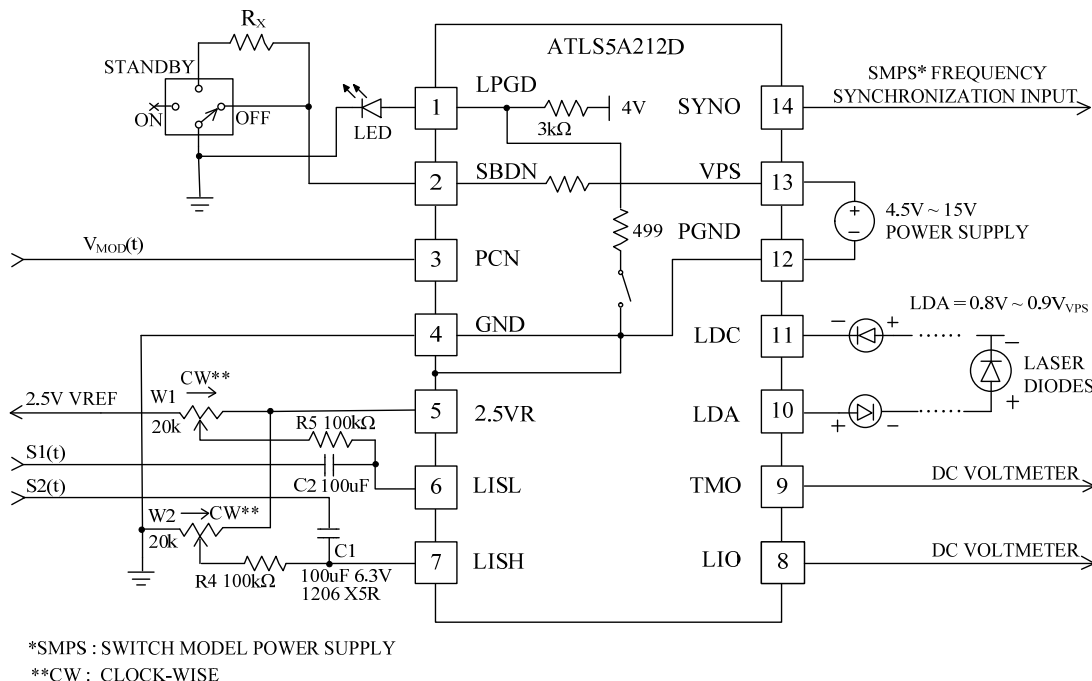

Figure 7. A Typical Stand-alone Application Schematic

Figure 7 shows a typical stand-alone application circuit.

Digital signal V1 and V2 control the laser driver into Shutdown, Standby or Operation mode. The starting up time delay is about 20mS and the shut down time is about 20µs.

It is worth mentioning that to achieve high speed and low distortion digital modulation, one can use the LISL pin to set a current that is a little lower than the threshold current of the laser diode to turn off the laser beam, such as half of its value, use the LISH pin to set the laser current when the laser diode is turned on. In this way, the laser beam is turned on and off, while the driver control loop is always kept on, so that the output stage is always under control, no distortion is caused by turning on/off the output stage.

When no modulation is needed, one can leave PCN pin unconnected, LISL connect pin to GND, and use LISH to set the output current.

In Figure 7, the LED is used to indicate laser diode status. When LPGD pin is high, >2V, the laser diode control loop is

working properly. When LPGD pin is low, <0.3V, the laser diode control loop is not working properly, there might be a short or open circuit at the laser diode, or the laser driver is put into Standby or Shutdown mode. The LPGD pin can also be connected to a digital input pin of a micro-controller, when software/firmware is utilized in the system. See Figure 7. The equivalent circuit of LPGD pin is a 3kΩ resistor pulling it up to 4V rail and an open drain FET, 500Ω, pulling it down to the ground. The pull-up current can be increased by connecting an external pull-up resistor between LPGD and VPS. Tie this added additional pull up resistor to a 3.3V or 5V power supply if they are available. Make sure that the pull up current is not too high, otherwise, the internal open drain FET cannot pull-down the LPGD pin low enough to turn off the LED.

The laser diodes are connected between LDA and LDC pins. It is worth mentioning that the power supply return terminal should be connected to the pin 12 PGND.

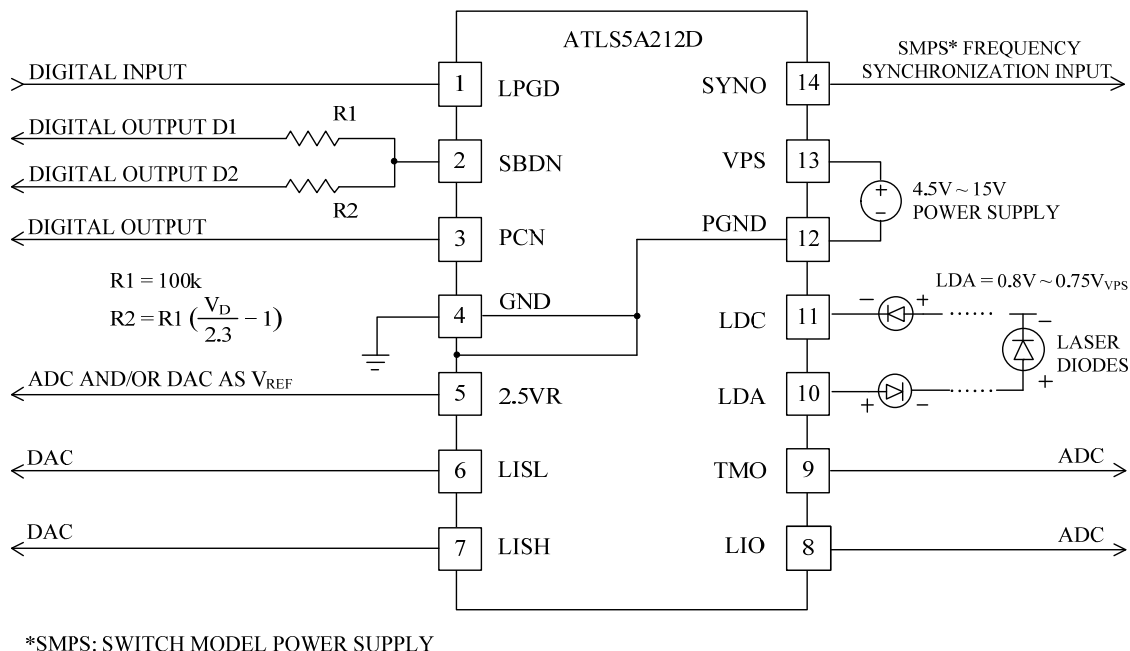

Figure 8. A Typical Microcontroller-based Application Schematic

Figure 8 shows a typical micro-controller-based application circuit.

Table 3 shows the relationship between Digital D1, D2, and laser driver state. Refer to Figure 4.

Table 3.

Digital Output D1	Digital Output D2	Laser Driver State
0	0	Shutdown
0	1	Standby
1	0	Note
1	1	Operation

Note: For the input state D1=1 and D2=0, the controller's state is depending on the output voltage at SBDN pin:

$$V_{SBDN10} = \frac{R2}{R1+R2} \times V_D$$

$$V_{SBDN01} = \frac{R1}{R1+R2} \times V_D$$

Where, V_D is the logic1 output voltage for D1 & D2 signals.

Minimizing the Output Noise

The ATLS5A212 has extremely low output noise, and care must be taken in using this laser driver to achieve this lower noise performance. One of the noise sources is the beating frequency interference from other power mode electronics, such as another laser driver, TEC (Thermo-Electric Cooler) controller, or power supply. There are 2 ways to avoid the frequency beating: set the switching frequencies of other electronics to be far away from the switching frequency of the laser driver, 500kHz, or synchronize the other electronics switching with this laser driver. For this purpose, there is a SYNO pin, which can be used by other electronics as the switching trigger signal.

Turning On and Off

The driver can be turned on and off by setting the SBDN pin high and low respectively. It is recommended to turn the driver on by this sequence:

To turn on: turn on the power by providing the power supply voltage to the driver on VPS pin, turn on the driver by releasing the SBDN pin.

To turn off: turn off the driver by lowering the voltage of SBDN pin, turn off the power by stopping the voltage supply on the VPS pin.

When not controlling by the SBDN pin: leave it unconnected and turn on and off the driver by the power supply.



Adjusting the Output Current

In typical standalone configuration the output current is set by adjusting W1 and W2, which set input voltages of LISL and LISH, pin 6 and 7 respectively. See Figure 7. The output current will be:

$$I_{OUT} = 1.2 \times V_{LISL} \text{ or } 1.2 \times V_{LISH} \text{ (A)}$$

LISL and LISH can also be set using DAC as in Figure 8. Make sure that DAC has low output noise.

Monitoring the Output Current

The output current of the driver can be monitored by measuring the voltage on the LIO pin. This feature is very useful for micro-controller based system where the ADC is available and monitoring the current in real time is required. This pin provides a very low noise voltage signal and is proportional to the output current:

$$I_{OUT} = 1.2 \times V_{LIO} \text{ (A)}$$

For example, when the output current is 5A, the output signal is 2.5V.

LIO can be used to drive an ADC directly, and also be measured by a multi-meter.

Driver Power Consumption

The best way for arranging the heat sinking for the driver is as follows: transferring the heat by sandwiching a piece of thermal conductive pad between the top metal surface of the laser driver and the internal metal surface of the final product as shown in Figure 9.1 and 9.2 below. The recommended thickness of the thermal conductive pad in Figure 9.1 is 1~4mm, and in Figure 9.2 is 0.5mm. ATI also provides a series of thermal conductive pads, click [here](#) for more information.

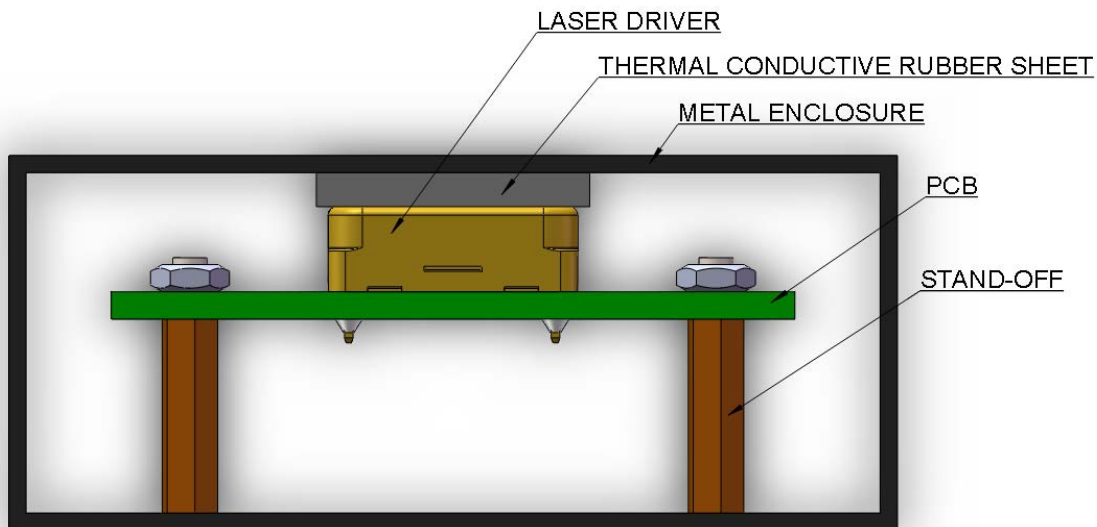

Figure 9.1 Transferring Heat with Metal Enclosure

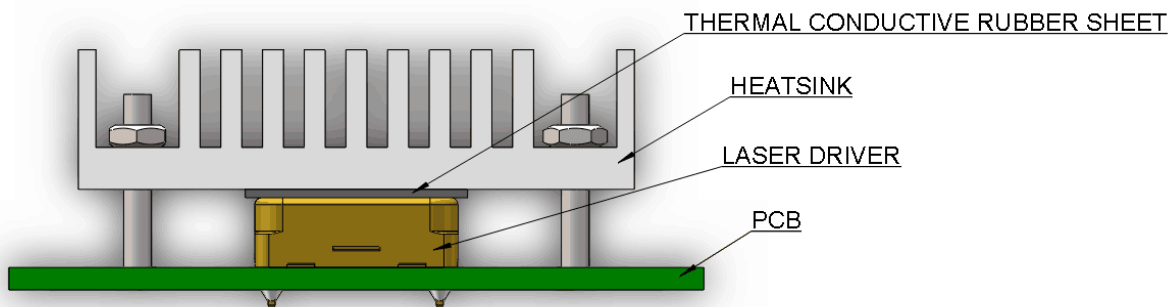

Figure 9.2 Transferring Heat with Heat Sink

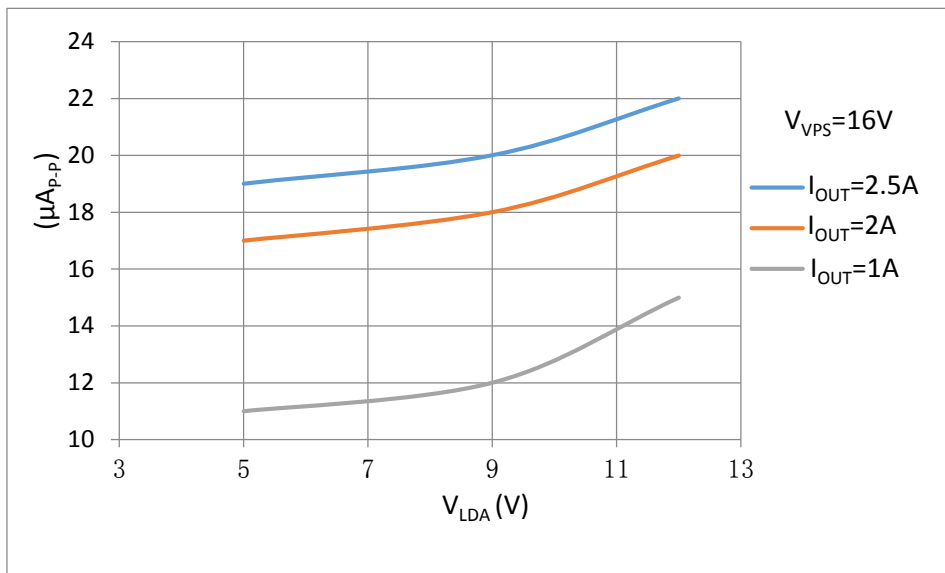

Figure 10.1. V_{LDA} vs. Output Current Noise@0.1Hz~10Hz

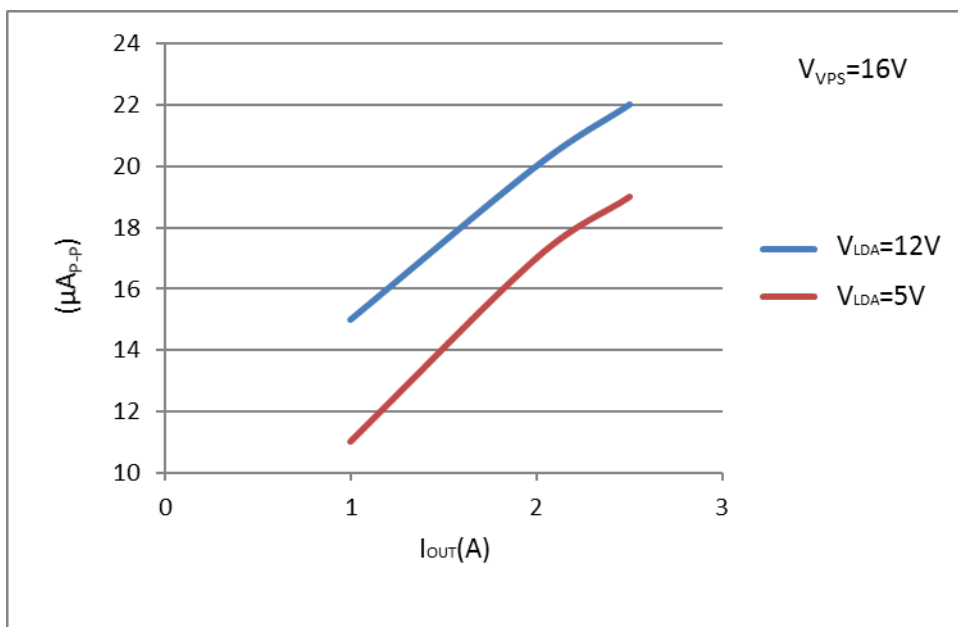
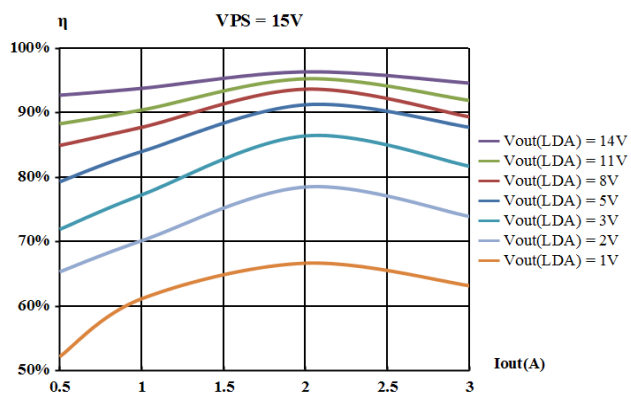
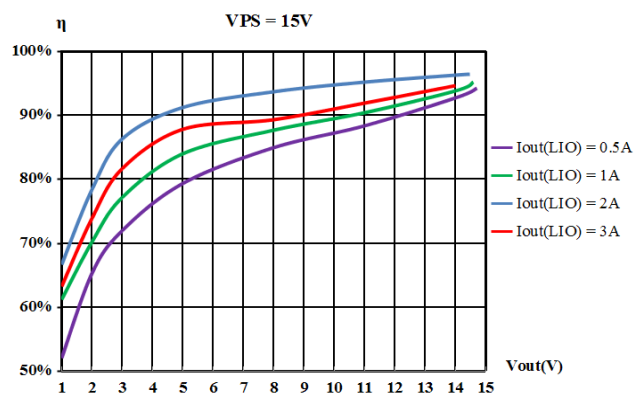

Figure 10.2. I_{OUT} vs. Output Current Noise@0.1Hz~10Hz



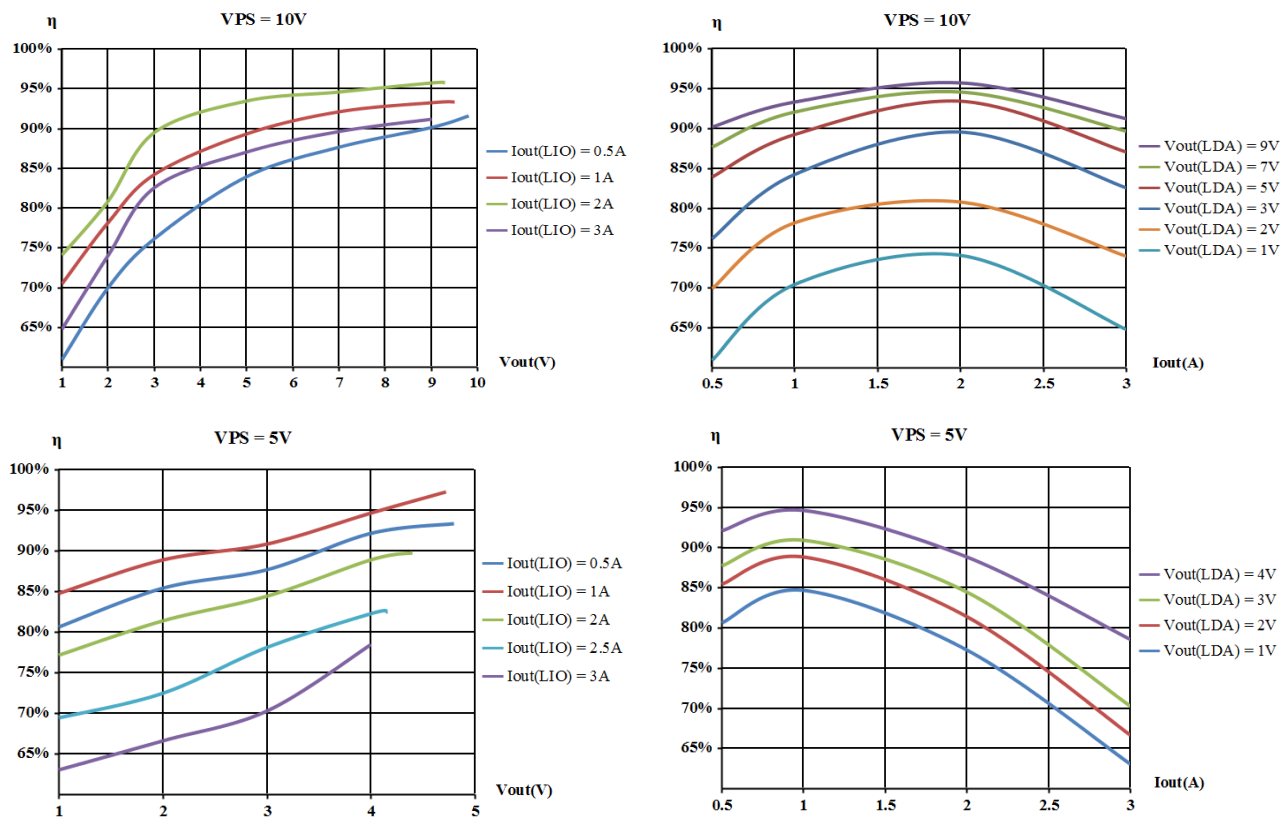
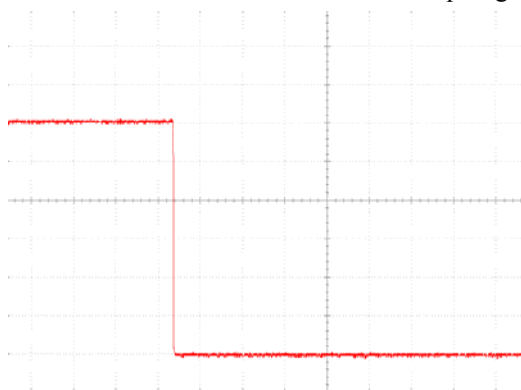
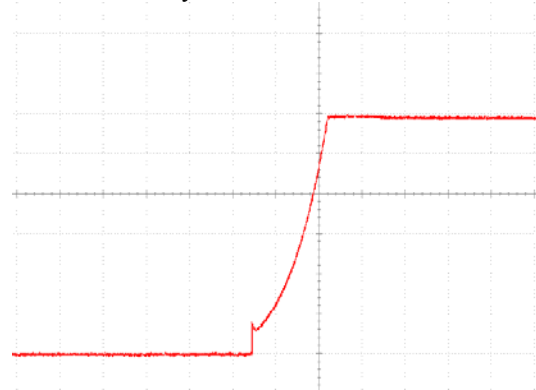

Figure 11. Efficiency of Laser Driver

Figure 12 shows the waveforms of soft start and stop. Figure 12 shows the efficiency of the laser driver.



The soft stop of shutdown by both power supply and the switch. When the current is 0.2A, the voltage is 6V.



The soft start of startup by both power supply and the switch. When the current is 0.2A, the voltage is 6V.

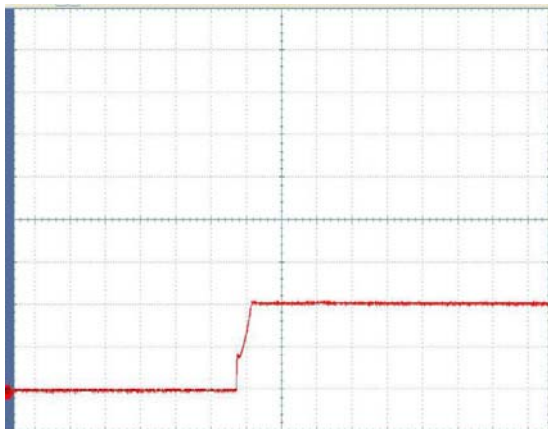

The soft start of startup by both power supply and the switch. When the current is 0.2A, the voltage is 2V.

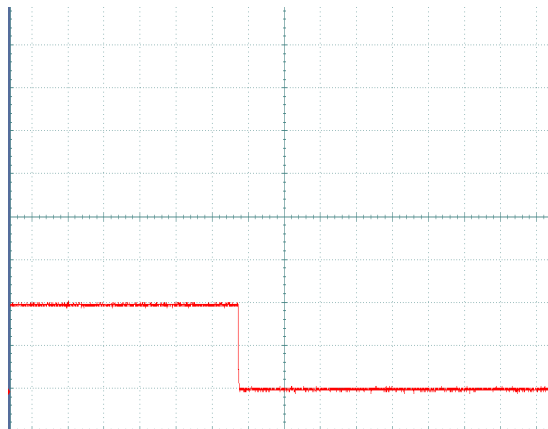

The soft stop of shutdown by both power supply and the switch. When the current is 0.2A, the voltage is 2V.

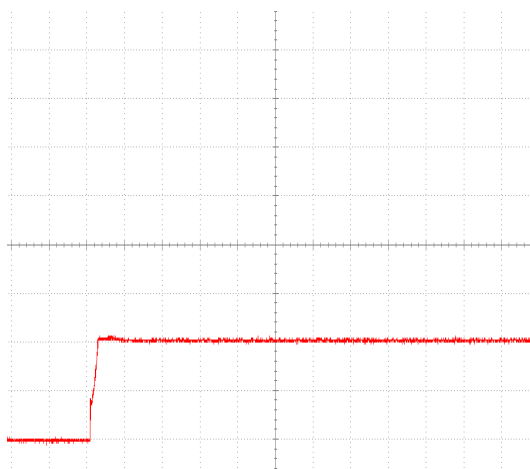

The soft start of startup by both power supply and the switch. When the current is 1A, the voltage is 2V.

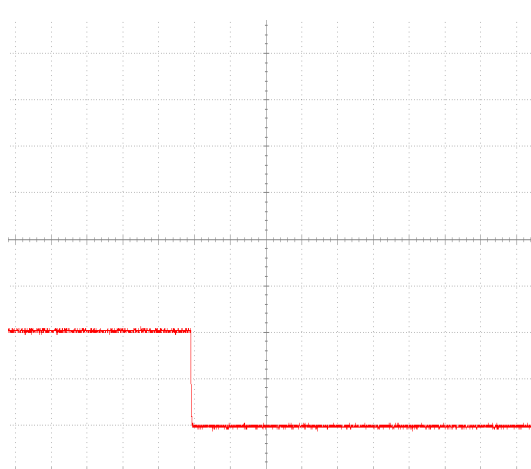

The soft stop of shutdown by both power supply and the switch. When the current is 1A, the voltage is 2V.

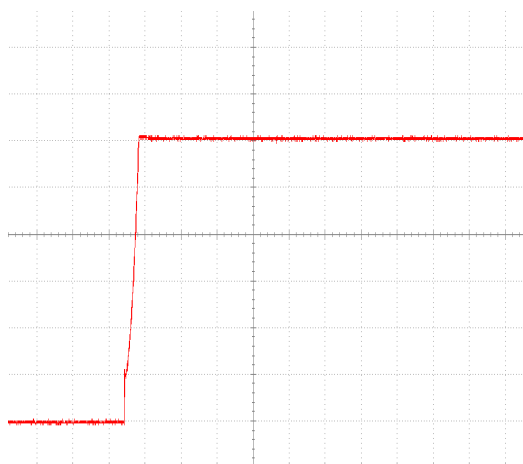

The soft stop of startup by both power supply and the switch. When the current is 1A, the voltage is 6V.

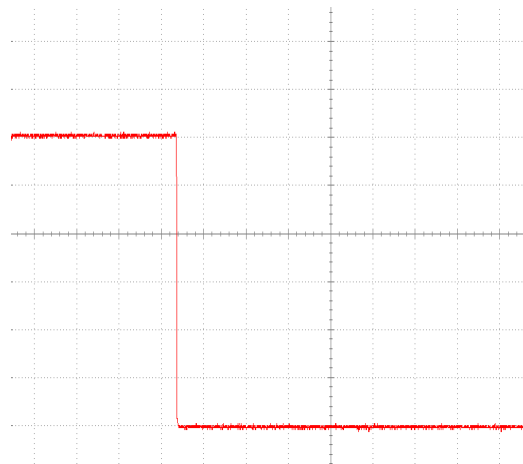

The soft start of shutdown by both power supply and the switch. When the current is 1A, the voltage is 6V.

Figure 12. Waveforms of Soft Start and Stop



Figure 13 and Figure 14 show LIO signal waveforms. Load=1Ω.

As shown in Figure 13, Figure 13.1 and Figure 13.2, when a square wave of -100mV ~ +100mV, f = 100Hz, is applied to LISL (LISH), measure the waveform of LIO. The rise time should be about 100μs, and the fall time should be about 100μs.

As shown in Figure 14, when a square wave of 0.5V ~ 1.7V, f = 100Hz, and the red waveform is applied to LISL (LISH), measure the waveform of LIO (yellow).

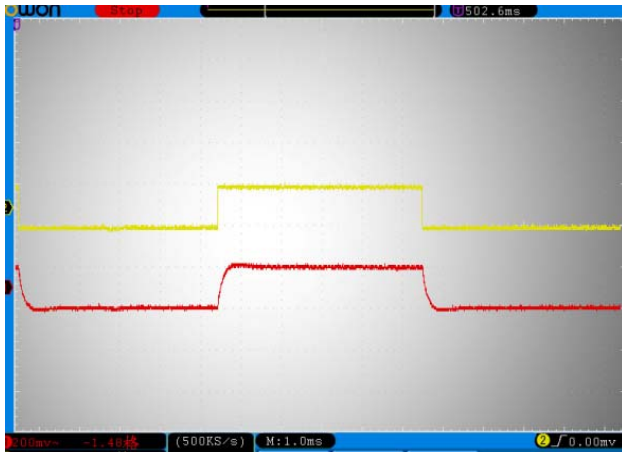

Figure 13. Small Signal Modulation

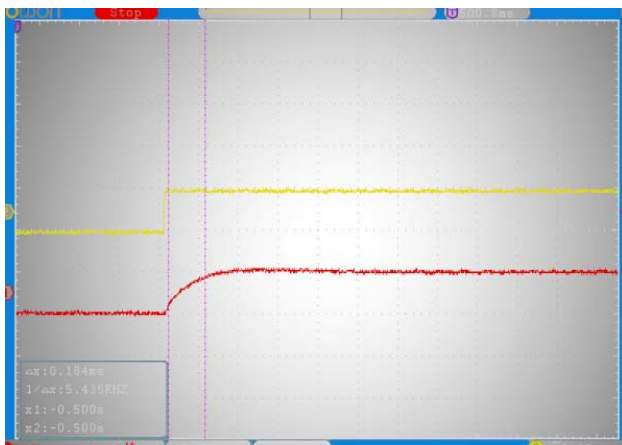

Figure 13.1. The Rise Signal Modulation

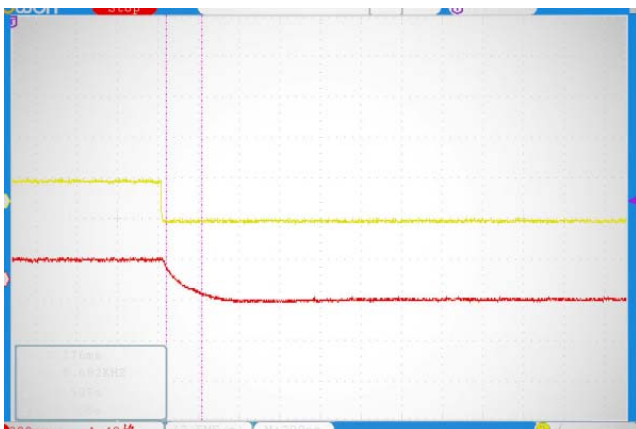

Figure 13.2. The Fall Signal Modulation

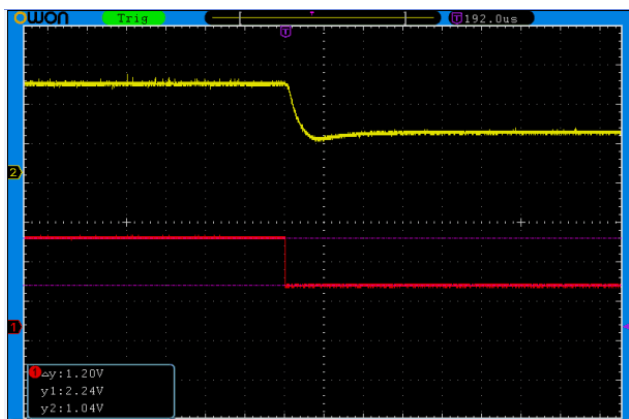
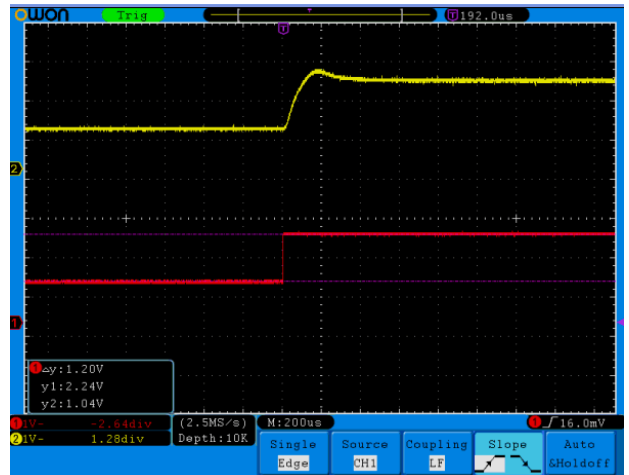
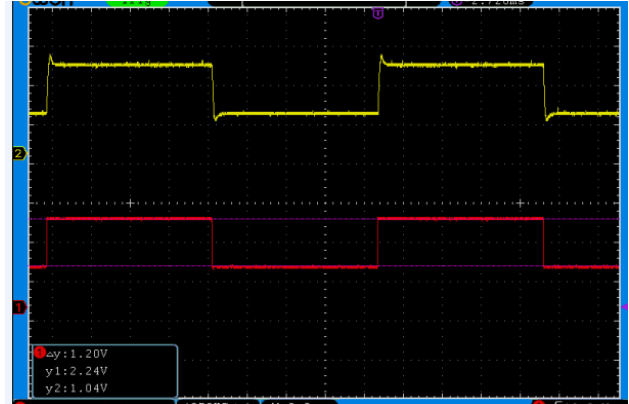

Figure 14. LIO Signal Waveform



First Time Power Up

Laser diode is a high value and vulnerable device. Faults in connections and damages done to the driver during soldering process may damage the laser diode permanently.

To protect the laser diode, it is highly recommended to use 3 to 18 regular diodes which have more than 5A average current rating to form a "dummy laser" and insert it in the place of the real laser diode, when powering up the driver for the first time. Use an oscilloscope to monitor the LDA voltage at times of powering up and enabling the shutdown pin, and powering down the laser driver and turning off the shutdown pin, and make sure that there is not over-shoot in output voltage at the LDA pin. At the same time, uses an ammeter in series with the dummy laser, to make sure that the output current is correct.

After thoroughly checking and making sure of free of faults in the system, disconnect the dummy laser diode and connect the real laser diode in place.

The driver output voltage range for the laser is between 0.8V to 0.9V_{VPS}.

Warning: Both the surface mount and the through hole types of packages can only be soldered manually on the board by a solder iron of < 310°C (590°F), do not use a reflow oven to solder this laser driver.

OUTLINE DIMENSIONS

The driver comes in DIP package: through hole mount. Dimensions of the DIP package are shown in Figure 16.

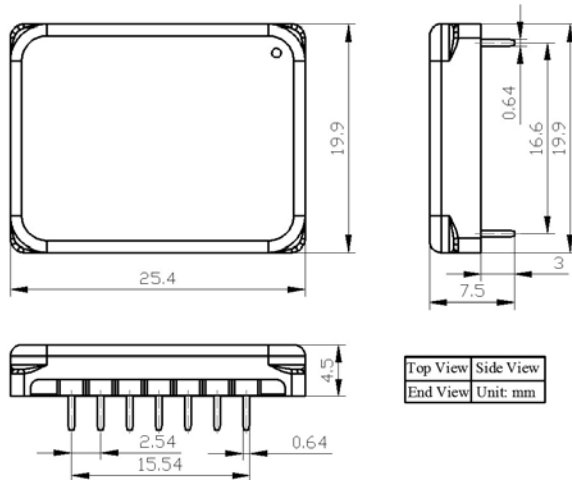

Figure 16. Dimensions of the DIP Package Driver

Figure 17 shows the view is seen from the side of the PCB.

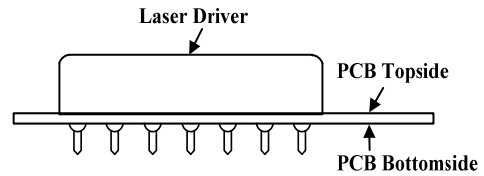

Figure 17. Side View of the Laser Driver mounted on PCB

Figure 18 shows the foot-print seen from the top side of the PCB, therefore, it is a vertical view.

"Tent" all the vias under the driver, i.e. cover the entire via by the solder mask layer, otherwise the vias can be shorted by the bottom plate of the driver which is internally connected the ground.

See Figures 18 and 19, it is recommended to use large copper fills for VPS, PGND, LDC and LDA pins, and other pins if possible, to decrease the thermal resistance between the module and the supporting PCB, to lower the module temperature.

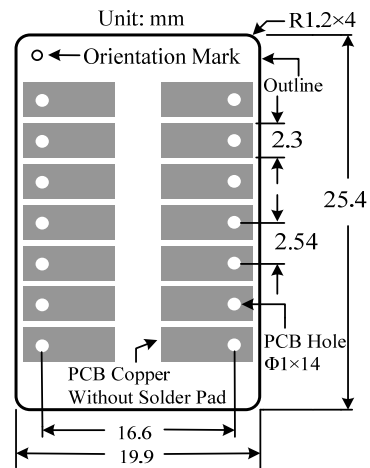

Figure 18. Top View of the Top Side PCB Foot-print

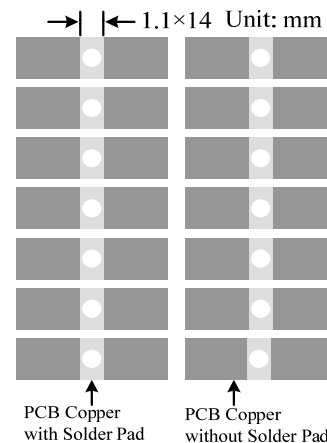

Figure 19. Top View of the Bottom Side PCB Foot-print
Figure 19 shows the foot-print seen from the bottom side of the PCB.



It is highly recommended to lower solder iron temperature to 310°C (590°F) and solder the driver manually, so that the internal contents of the driver would not be affected. After the soldering, it is also safe to check the laser driver’s functionality by using the “dummy laser” before connecting a real laser diode as mentioned previously on page 4.

NOTE:

The power supply may have over-shoot, when happens, it may exceed the maximum allowed input voltage, 16V, of the controller and damage the controller permanently. To avoid this from happening, do the following:

1. Connect the controller solid well with the power supply before turning on the power.
2. Make sure that the power supply has sufficient output current. It is suggested that the power supply can supply 1.2 to 1.5 times the maximum current the controller requires.
3. When using a bench top power supply, set the current limit to >1.5 times higher than the maximum current the controller requires.

ORDERING INFORMATION

Table 3. Part Number

Part Number	Description
ATLS5A212D	5A constant current driver in DIP package

Table 4. Unit Price

Quantity (pcs)	1 – 9	10 – 49	50 – 199	200 –499	≥500
Unit Price	\$103.9	\$99.9	\$95.9	\$91.9	\$87.9

NOTICE

1. ATI warrants performance of its products for one year to the specifications applicable at the time of sale, except for those being damaged by excessive abuse. Products found not meeting the specifications within one year from the date of sale can be exchanged free of charge.
2. ATI reserves the right to make changes to its products or to discontinue any product or service without notice, and advise customers to obtain the latest version of relevant information to verify, before placing orders, that information being relied on is current and complete.
3. All products are sold subject to the terms and conditions of sale supplied at the time of order acknowledgment, including those pertaining to warranty, patent infringement, and limitation of liability. Testing and other quality control techniques are utilized to the extent ATI deems necessary to support this warranty. Specific testing of all parameters of each device is not necessarily performed, except those mandated by government requirements.
4. Customers are responsible for their applications using ATI components. In order to minimize risks associated with the customers’ applications, adequate design and operating safeguards must be provided by the customers to minimize inherent or procedural hazards. ATI assumes no liability for applications assistance or customer product design.
5. ATI does not warrant or represent that any license, either express or implied, is granted under any patent right, copyright, mask work right, or other intellectual property right of ATI covering or relating to any combination, machine, or process in which such products or services might be or are used. ATI’s publication of information regarding any third party’s products or services does not constitute ATI’s approval, warranty or endorsement thereof.
6. IP (Intellectual Property) Ownership: ATI retains the ownership of full rights for special technologies and/or techniques embedded in its products, the designs for mechanics, optics, plus all modifications, improvements, and inventions made by ATI for its products and/or projects.
7. If not utilizing the internal reference voltage source, the minimum power supply can be as low as 4.5V.