



Figure 1. Photo of Actual ATLS500MA201D

FEATURES

- High Efficiency: $\geq 90\%$
- Maximum Output Current: 500mA
- Current Output Noise: $2.74\mu A_{P-P}@0.1Hz \sim 10Hz$
- High Stability: 100ppm/ $^{\circ}C$
- Loop Good Indication
- Zero EMI
- Compact Size
- DIP Package Available
- 100 % Lead (Pb)-free and RoHS Compliant

APPLICATIONS

Driving laser diodes with low noise, including DPSSL, EDFA, fiber laser, direct diode lasers, etc.

DESCRIPTION

Table 1. Pin Function Descriptions

Pin #	Name	Type	Description
1	SDN	Digital Input	ATLS500MA201D: Shut down control. Negative logic, at the internal chip control input: $>1.4V = \text{enable}$, $<0.95V = \text{shut down}$. ATLS500MA201D-PD: Shut down control. Positive logic, at the internal chip control input: $<0.95V = \text{enable}$, $>1.4V = \text{shut down}$. There is a pull-down resistor of 55k to the ground.
2	LDGD	Digital Output	Laser diode good. When this pin is high, $>2V$, the control loop is working properly. When this pin is low, $<0.3V$, the laser diode is bad, or there is a short or open circuit at the laser diode.
3, 7	GND	Signal Ground	Signal ground pin. Connect ADC and DAC grounds to here.
4	2.5VR	Analog Output	Reference voltage. It can source 3mA max, with $5\mu V_{P-P}$ noise @ 0.1 to 10Hz and 25ppm/ $^{\circ}C$ stability max.

This laser driver is an electronic module designed for driving diode lasers with up to 500mA constant current, high efficiency, low noise, high reliability, zero EMI, and small package. Figure 1 shows the photo of an actual ATLS500MA201D.

It provides these the functions: laser constant current control, laser current monitoring, over current and thermal protection, laser current control indication, laser diode status indication, soft start, and shut down.

It comes with a high stability low noise 2.5V voltage reference output which can be used for setting the output current. The reference output can also be used for the ADCs (Analog to Digital Converters) and/or DACs (Digital to Analog Converters).

Warning: The through hole type of modules can only be soldered manually on the board by a solder iron of $< 310^{\circ}C$ ($590^{\circ}F$), not go through a reflow oven process.

The ATLS500MA201D is packaged in a 6 sided metal enclosure, which blocks EMIs (Electro-Magnetic Interferences) to prevent the driver and other electronics from interfering each other.

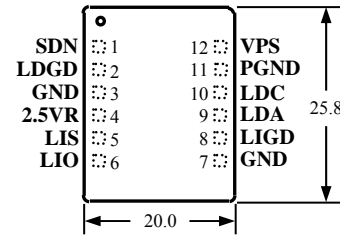

Figure 2 Pin Names and Locations

Figure 2 is the actual size top view of the ATLS500MA201D, which shows the pin names and locations. Its thickness is 5.0mm. The ATLS500MA201D pin functions are shown in Table 1.

5	LIS	Analog Input	Laser current set-point voltage. There is an input resistor of 10M tied to GND. Setting it from 0V to 2.5V will set the laser current from 0A to 500mA linearly.
6	LIO	Analog Output	Laser current output indication. 0V to 2.5V indicates the laser current of from 0A to 500mA linearly.
8	LIGD	Analog Output	Laser current good, control loop indication. When this pin is stabilized and the value is between 1V and 2.4V, the output voltage to the laser, Pin 9 LDA, will be 4.5V to 0V linearly, the laser current is stabilized, and the control loop is stable.
9	LDA	Analog Output	Laser diode anode. Connect it to the anode of the laser diode.
10	LDC	Analog Output	Laser diode cathode. Connect it to the cathode of the laser diode.
11	PGND	Power Ground	Power ground pin. Connect this pin directly to power supply return pass.
12	VPS	Power Input	Power supply voltage. The driver will work from $V_{VPS} = 3.0V$ to 5.5V.

SPECIFICATIONS

Table 2. Characteristics ($T_{ambient} = 25^{\circ}C$)

Parameter	Test Condition	Value	Unit
Laser driver efficiency	$I_{OUT} = 1A, V_{OUT} = 2.5V, \& V_{VPS} = 5V$	≥ 90	%
Maximum output current	$V_{LDA} \leq V_{LDA_{MAX}}$	0.5	A
Output current noise ($V_{IN} = 5V; V_{OUT} = 2.5V;$ $I_{OUT} = 500mA$)	$V_{IN} = 5V; V_{OUT} = 2.5V;$ $I_{OUT} = 500mA$	2.74	μA_{P-P} @0.1Hz-10Hz
Stability @ 1A	The range of T_A is $20^{\circ}C \sim 80^{\circ}C$	± 0.2	%
Laser current control signal range at LIS	$V_{VPS} = 3.1V \sim 6V$	$0 \sim V_{VPS} - 0.2$	V
LIS control accuracy	Relative accuracy = (accuracy current – set point current) / set point temp.	± 0.2	%
Laser current indication signal range at LIO	$V_{VPS} = 3.1V \sim 6V$	$0 \sim 2.5$	V
LIO indication accuracy	$V_{VPS} = 3.1V \sim 6V$	± 0.2	%
Reference voltage	$V_{VPS} = 3.1V \sim 6V$	2.5	V
Reference Voltage temperature co efficiency	$V_{VPS} = 3.1V \sim 6V$		
Output voltage range at LDA	$V_{VPS} = 3.1V \sim 6V$	Depending on V_{VPS}	V
PWM frequency		500	kHz
Power supply voltage range		$3.1 \sim 6$	V
Maximum power supply voltage	–	6	V
Start-up time		4	ms
Typical pull-down current at LDGD		6	mA
Operating case temperature	$I = 1A, V_{IN} = 3.3V$ or $5V, V_{OUT} = 2.5V$	$-40 \sim 85$	$^{\circ}C$
Rise times of small signal	$I_{OUT} = 1A, V_{OUT} = 2.5V, \& V_{VPS} = 5V$	70	μS
Fall times of small signal	$I_{OUT} = 1A, V_{OUT} = 2.5V, \& V_{VPS} = 5V$	70	μS
Rise times of large signal		352	μS
Fall times of large signal		184	μS

OPERATION PRINCIPLE

The block diagram of the driver is shown in Figure 3. The shut down control circuit accept signals from 3 sources: external shut down, over current and over temperature signals. When one of these signals is activated, the driver is shut down. Only when all these 3 signals go up, the soft start

circuit starts enabling the low noise driver.

An internal soft start circuit allows a slow start up and a quick shut down.

The high stability low noise 2.5V voltage reference can be used for setting the output current, and also be used for the ADCs

and/or DACs.

It comes with a laser diode status indication circuit. When LDGD pin is high, >2V, the control loop is working properly. When this pin is low, <0.3V, the laser diode is bad, or there is a short or open circuit at the laser diode.

It comes with a laser current control indication. This pin has a similar function as Pin 2 LDGD, except that this pin is of an analog output and Pin 2 is of a digital output.

The current measurement circuit monitors the output current and shuts down the driver upon detecting the output current exceeds the pre-set value.

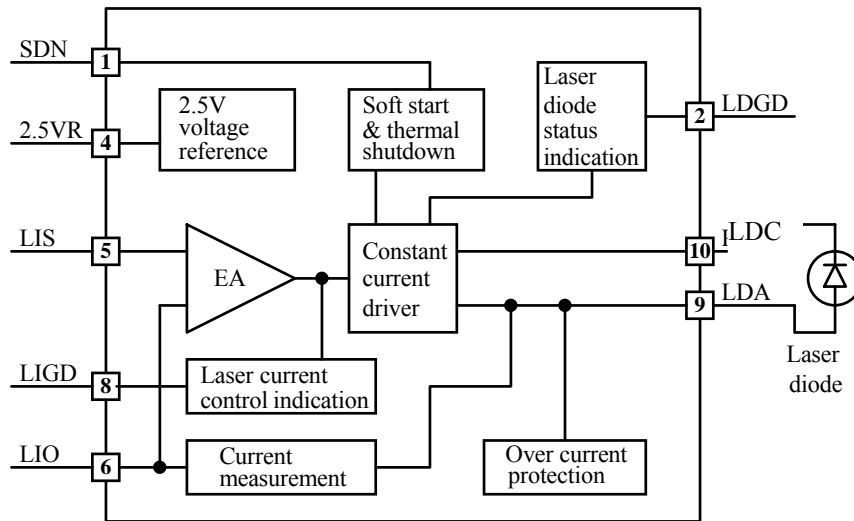

Figure 3. Block Diagram

APPLICATION INFORMATION

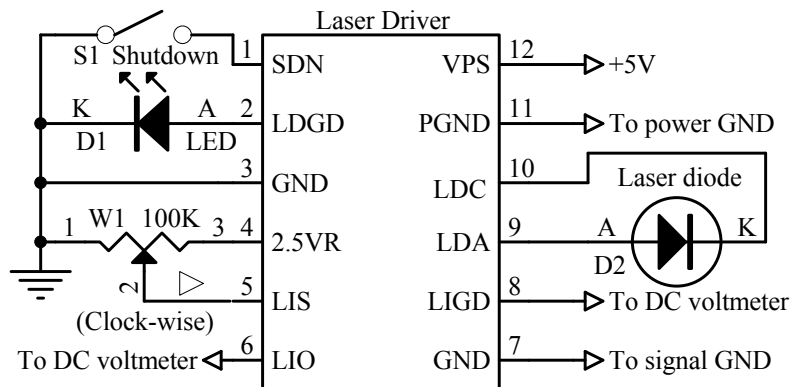

Figure 4.1. A Typical Stand-alone Application Schematic for ATLS500MA201D

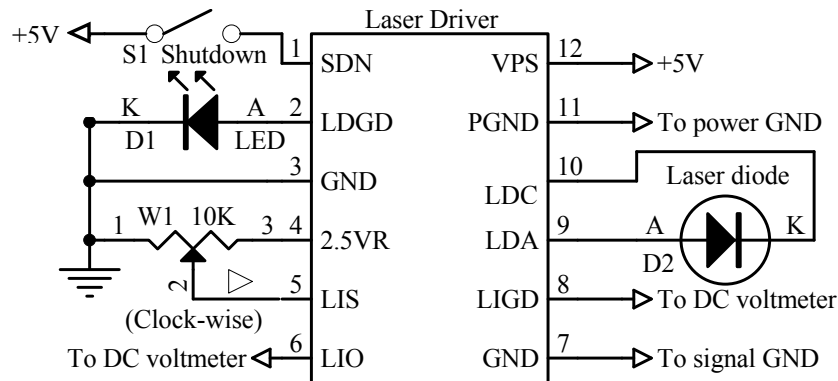

Figure 4.2. A Typical Stand-alone Application Schematic for ATLS500MA201D-PD

Figure 4.1 and 4.2 shows a typical stand-alone application circuit.

In Figure 4.1, the switch S1 is external shut down switch, which can turn on and off the driver with the SDN pin high and lower respectively, at the internal chip control input: >1.4V = enable, <0.95V = shut down, normal threshold voltage = 1.2V. The switch S1 can also be an electronic switch, such as an I/O pin of a micro-driver, with an either open drain or push/pull output. See Figure 5. If not using a switch (S1) to control the laser, leave the SDN pin

unconnected.

In Figure 4.1, the LED D1 is used to indicating laser diode status. When LDGD pin is high, >2V, the laser diode control loop is working properly. When LDGD pin is low, <0.3V, the laser diode is bad, or there is a short or open circuit at the laser diode. The LDGD pin can also be connected to a digital input pin of a micro-driver, when software/firmware is utilized in the system. See Figure 5.

Figure 5 shows a typical micro-processor-based application circuit.

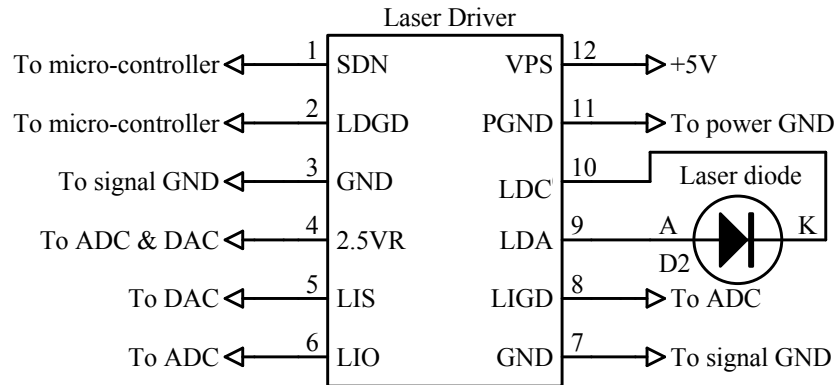

Figure 5. A Typical Micro-processor-based Application

In Figure 4.1, the adjustable resistor W1 is used to setting the output current. Setting LIS from 0V to 2.5V will set the laser current from 0A to 500mA linearly.

The laser diode D2 is connected between LDA and LDC. It is worth mentioning that the power supply return terminal should be connected to the pin 11 PGND and the cathode of the laser diode should be connected to the pin 10 LDC. These 2 nodes should not be connected together externally and they are connected together internally already by the driver.

Turning the Driver On and Off

The driver can be turned on and off by setting the SDN pin high and lower respectively. It is recommended to turn the driver on by this sequence:

To turn on: turn on the power by providing the power supply voltage to the driver, turn on the driver by releasing the SDN pin.

To turn off: turn off the driver by lowering the voltage of SDN pin, turn off the power by stopping the voltage supply on the VPS pin.

When not controlling by the SDN pin: leave it unconnected and turn on and off the driver by the power supply.

Adjusting the Output Current

The output current is set by adjusting W1, which sets input voltages of LIS, pin 5. See Figure 4.1. The output current will be:

$$I_{OUT} (A) = 0.5 (A) \times V_{LIS} (V) / 2.5 (V).$$

LIS can be configured by using a DAC, to replace the W1 in Figure 4.1. Make sure that the DAC has output low noise, or, if no modulation is needed, an RC low pass filtered by be inserted between the DAC and the LIS pin. See Figure 5.

The LIO can still be used to monitor the output current when the LIS is adjusted. 0V to 2.5V indicates the laser current of from 0A to 500mA linearly.

Monitoring the Output Current

The output current of the driver can be monitored by measuring the voltage on the LIO pin. This feature is very useful for micro-driver based system where the ADC is available and monitoring the current in real time is required. This pin provides a very low noise voltage signal which is proportional to the output current:

$$V_{LIO} (V) = 2.5 (V) \times I_{OUT} (A) / 0.5 (A).$$

For example, when the output signal equals to 2.5V, the output current is 500mA.

LIO can be used to drive an ADC directly, and also be measured by a multimeter during debugging process.

Figure 6 shows the relationship between Pin VPS and LDA.

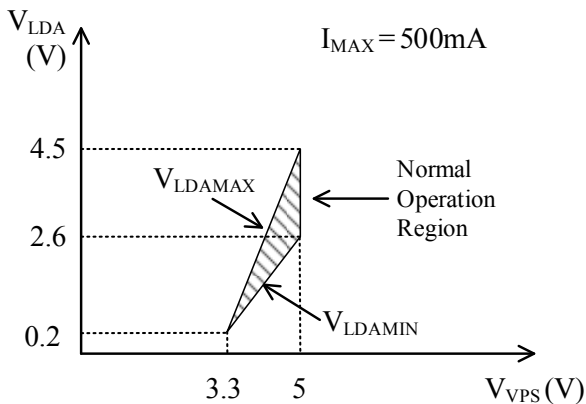

Figure 6. V_{VPS} vs. V_{LDA}

Driver Power Consumption

The power consumption of the driver can be calculated by:

$$P_{DRIVER} = I_{IN} \times V_{VPS} - I_{OUT} \times V_{LDA},$$

where P_{DRIVER} is the power consumed by the driver itself; I_{OUT} is the output current;

I_{IN} is the power supply's input current;

V_{VPS} is the power supply voltage;

V_{LDA} is the voltage across the laser diode;

$$\eta = (I_{OUT} \times V_{LDA}) / (I_{IN} \times V_{VPS}).$$

When P_{DRIVER} of ATLS500MA201D exceeds 1W, a heat sink might be needed. The best way for arranging the heat sinking for the driver is as follows: transferring the heat by sandwiching a piece of gap filler material between the top metal surface of ATLS500MA201D and the internal metal surface of the final product as shown in Figure 7 below.

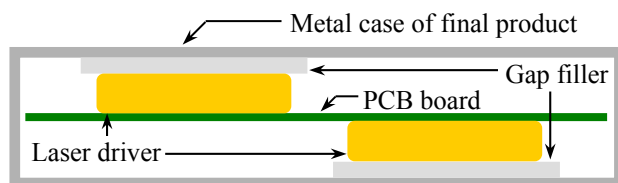

Figure 7. Transferring heat by the gap filler

The gap filler material needs to be mechanically elastic and thermally conductive. One of such products is the T-flex 200 filler sheet made by Lairdtech, the available thickness is between 1mm to 4mm. More detail technical data about this material can be found here: www.lairdtech.com.

To reduce the power consumed by the driver, we recommend

using a power supply with its voltage being only about 0.5V (approximately, see below for a more accurate estimate) above the maximum output voltage. For example, for most diode lasers at 500mA, the maximum forward voltage across the laser is about 2.8V, thus, using a 3.3V power supply would result in a much lower power consumption compared with using a 5V power supply. Please make sure:

$$V_{VPS} \geq V_{LDAMAX} + 0.15V_{VPS},$$

where V_{LDAMAX} is the maximum possible laser diode voltage.

First Time Power Up

Laser is a high value and vulnerable device. Faults in connections and damages done to the driver during soldering process may damage the laser permanently.

To protect the laser, it is highly recommend to use 2 to 4 regular diodes of $>500mA$ to form a “dummy laser” and insert it in the place of the real laser diode, when powering up the driver for the first time. Use an oscilloscope to monitor the LDA voltage at times of power-up and power-down, make sure that there is not over-shoot in voltage. At the same time, use an ammeter in series with the dummy laser, to make sure that the output current is correct.

After thorough checking free of faults, disconnect the dummy laser and connect the real laser in place.

The driver output voltage range for the laser is between 0.5 to 4V when powered by a 5V power supply.

Driving High Voltage Laser Diodes

Some laser diodes have high forward voltage, such as 7V, while the laser driver ATLS500MA201D has a maximum output voltage of 4V. This section tells a way to drive such laser diodes by using this laser driver.

The schematic is show as in Figure 8. Where Power Supply 1 is the power supply for the laser driver, Power Supply 2 is for increasing the laser driver's maximum output voltage.

Please notice that the power on sequence has to be in this way: turn on Power Supply 1, turn on Power Supply 2, then turn on the laser driver by driving SDN (Shutdown) pin to logic high.

The sequence for turning off the laser circuit is: turn off the SDN pin by pulling it down to the logic low; turn off Power Supply 1; and then, turn off power supply 2.

To make sure the circuit works ok: turn on the laser, measure LDA voltage, it should be between 1V to 3V, at room temperature, the ideal LDA voltage is around 2V.

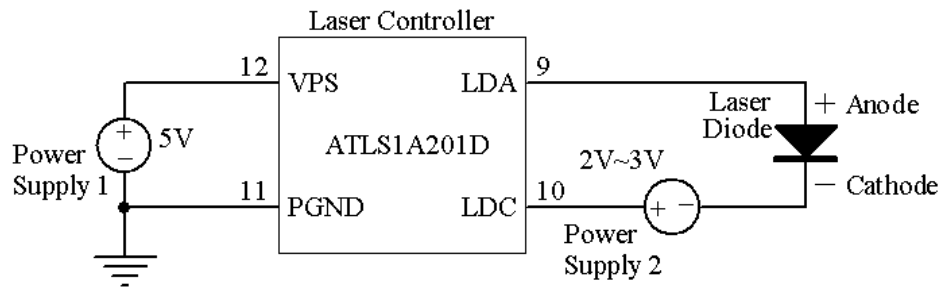

Figure 8. Driving High Voltage Laser Diodes

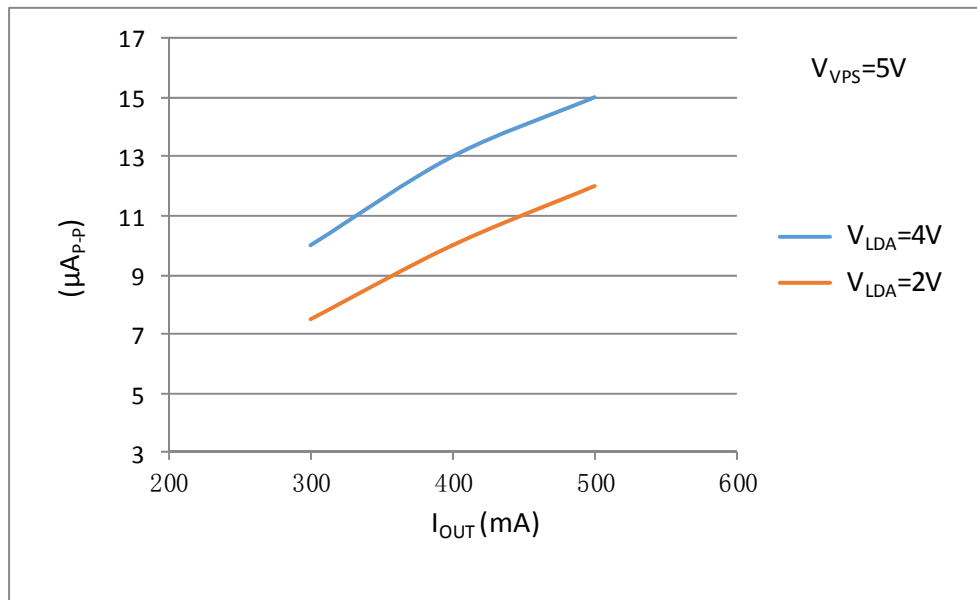

Figure 9. I_{OUT} vs. Output Current Noise@0.1Hz~10Hz

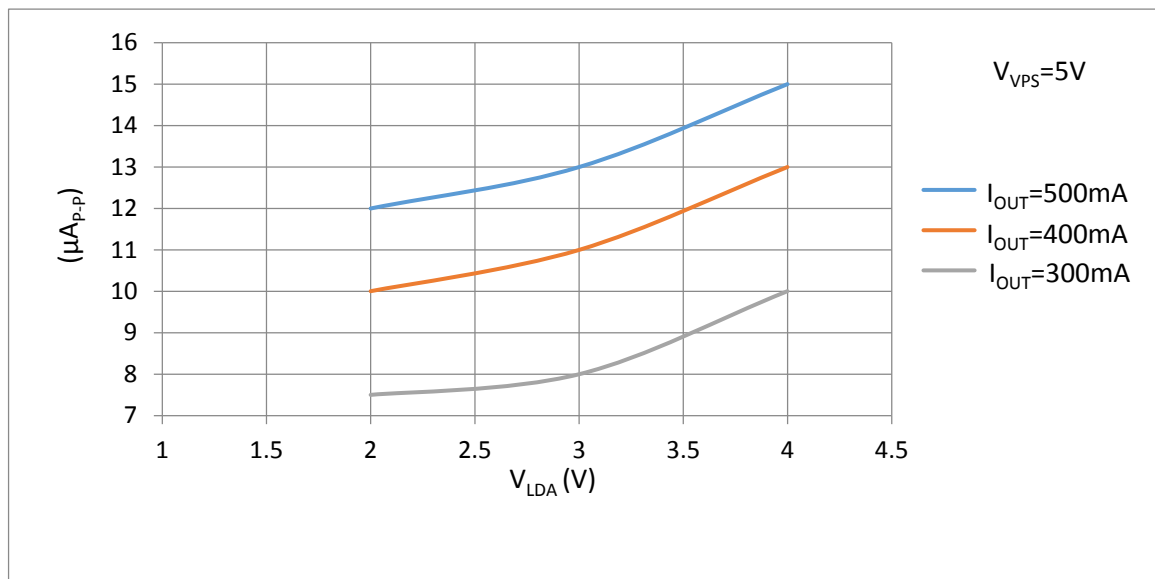

Figure 10. V_{LDA} vs. Output Current Noise@0.1Hz~10Hz

Warning: The through hole types of modules can only be soldered manually on the board by a solder iron of < 310°C (590°F), not go through a reflow oven process.

NOTE: The power supply may have overshoot, when happens, it may exceed the maximum allowed input voltage, 6V, of the controller and damage the controller permanently. To avoid this from happening, do the following:

1. Connect the controller solid well with the power supply before turning on the power.
2. Make sure that the power supply has sufficient output current. It is suggested that the power supply can supply 1.2 to 1.5 times the maximum current the controller requires.
3. When using a bench top power supply, set the current limit to >1.5 times higher than the maximum current the controller requires.

OUTLINE DIMENSIONS AND MOUNTING

The driver comes in only one package: through hole mount. It is often called DIP (Dual Inline package) or D (short for DIP) package and has a part number: ATLS500MA201D. Dimensions of the DIP package driver are shown in Figure 11.

See Figure 13 and 14, it is recommended to use large copper fills for VPS, LDC, and the LDA pins, and other pins if possible, to decrease the thermal resistance between the module and the supporting PCB, to lower the module temperature.

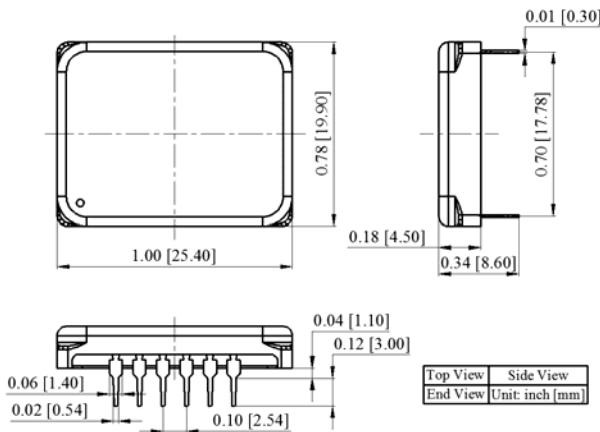

Figure 11. Dimensions of the DIP Package Driver
Laser Driver

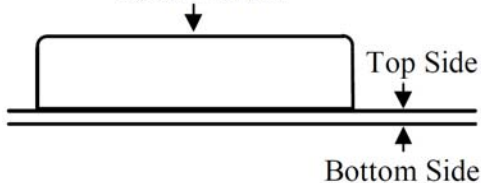

Figure 12. End View of the PCB Foot-print

“Tent” (i.e. cover the entire via by the solder mask layer) all the vias under the driver, otherwise, the vias can be shorted by the bottom plate of the driver which is internally connected the ground.

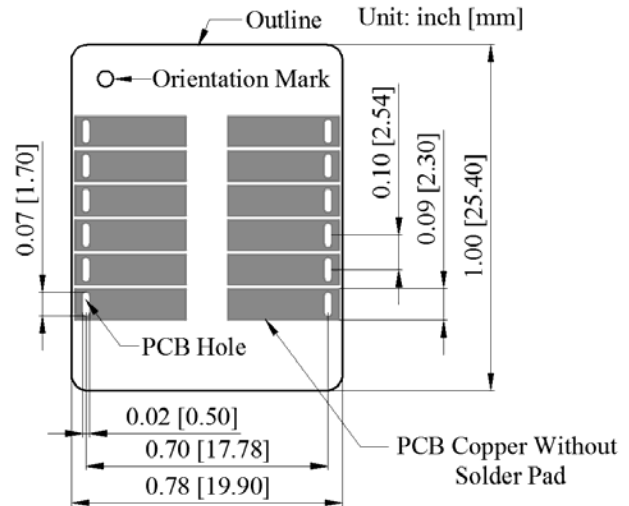

Figure 13. Top View of the Top Side PCB Foot-print

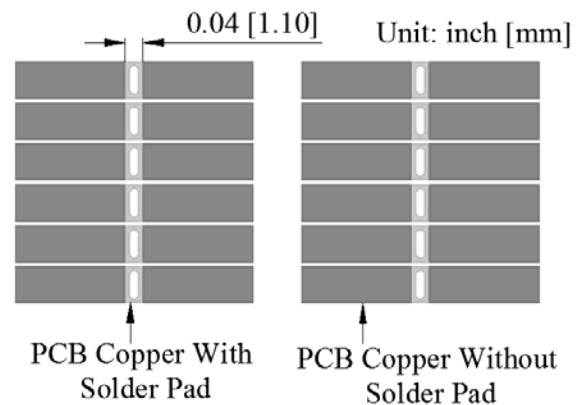

Figure 14. Top View of the Bottom Side PCB Foot-print

Figure 14 shows the foot-print which is seen from the bottom side of the PCB.



ORDERING INFORMATION

Table 3. Part Number

Part #	Description
ATLS500MA201D	500mA constant current driver in DIP package
ATLS500MA201D-PD	500mA constant current driver with a pull-down resistor of 55K to the ground in SDN pin

PRICES

Table 4. Unit Price

Quantity	1 – 9pcs	10 – 49pcs	50 – 199pcs	200-499pcs	≥500pcs
ATLS500MA201D	\$74	\$70.1	\$66.2	\$62.3	\$58.4
ATLS500MA201D-PD	\$74	\$70.1	\$66.2	\$62.3	\$58.4

NOTICE

- ATI warrants performance of its products for one year to the specifications applicable at the time of sale, except for those being damaged by excessive abuse. Products found not meeting the specifications within one year from the date of sale can be exchanged free of charge.
- ATI reserves the right to make changes to its products or to discontinue any product or service without notice, and advise customers to obtain the latest version of relevant information to verify, before placing orders, that information being relied on is current and complete.
- All products are sold subject to the terms and conditions of sale supplied at the time of order acknowledgment, including those pertaining to warranty, patent infringement, and limitation of liability. Testing and other quality control techniques are utilized to the extent ATI deems necessary to support this warranty. Specific testing of all parameters of each device is not necessarily performed, except those mandated by government requirements.
- Customers are responsible for their applications using ATI components. In order to minimize risks associated with the customers’ applications, adequate design and operating safeguards must be provided by the customers to minimize inherent or procedural hazards. ATI assumes no liability for applications assistance or customer product design.
- ATI does not warrant or represent that any license, either express or implied, is granted under any patent right, copyright, mask work right, or other intellectual property right of ATI covering or relating to any combination, machine, or process in which such products or services might be or are used. ATI’s publication of information regarding any third party’s products or services does not constitute ATI’s approval, warranty or endorsement thereof.
- IP (Intellectual Property) Ownership: ATI retains the ownership of full rights for special technologies and/or techniques embedded in its products, the designs for mechanics, optics, plus all modifications, improvements, and inventions made by ATI for its products and/or projects.