

Figure 1. Top View of ATLS25A219GUI

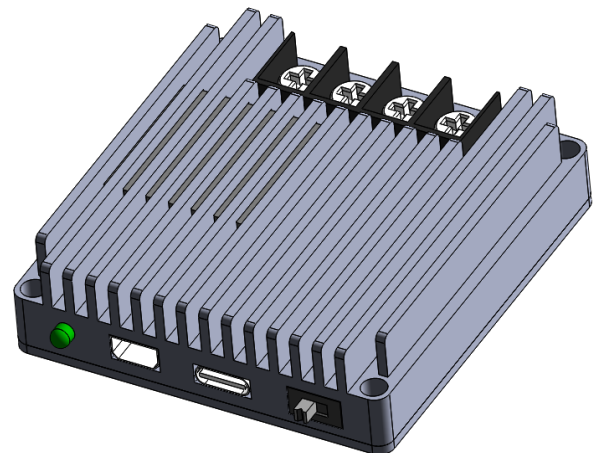

Figure 2. The 3D view of ATLS25A219GUI

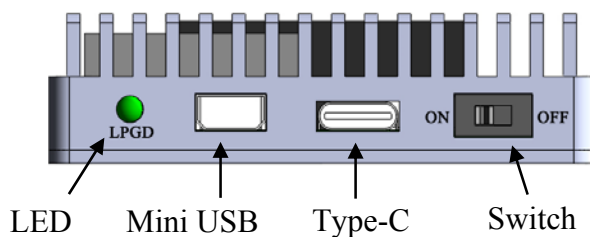

Figure 3. Side View

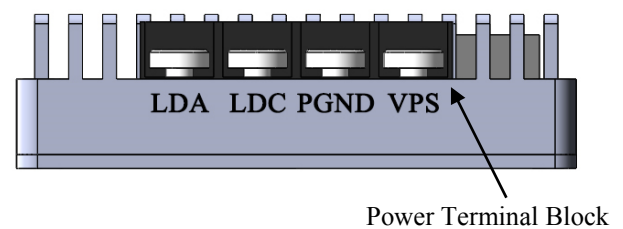

Figure 4. Side View

FEATURES

- Wide Input Voltage Range: 8.5V~40V
- Wide Output Voltage Range: $0.1 \times V_{VPS}$ to $0.8 \times V_{VPS}$ (input voltage)
- High Current Capability: 25A
- High Efficiency: $\geq 95\%$
($I_{OUT}=25A@V_{LDA}=30V \& V_{VPS}=40V$)
- Wide Modulation Bandwidth: DC~10kHz
- Compact Size: 63.0(L) × 61.0(W) × 16.7(H) (mm)
- Dual Independent Current Set Ports: LISH or LISL
- Direct Digital Modulation Control: PCN
- Three Control States: Shutdown, Standby and Operation
- Low Output Current Noise: $< 20\mu A_{p-p}@0.1Hz \sim 10Hz$
- High Current Stability: $< \pm 20mA@25A \& (-20^{\circ}C \sim 80^{\circ}C)$
- Low Output Ripple Voltage: $< 10mV_{p-p}@500kHz$
- Fully Shielded
- 100 % Lead (Pb)-free and RoHS Compliant

APPLICATIONS

Drive one or multiple laser diodes for DPSSL, EDFA, and fiber lasers with low noise high stability, and high efficiency.

DESCRIPTION

This laser driver, ATLS25A219GUI, is an electronic module that has all the valuable and important, but often difficult to achieve simultaneously, features: wide input and output voltage range, high output current capability, high efficiency, low output noise (but it has an output $10mV_{p-p}$ ripple voltage at 500kHz), wide modulation bandwidth, and small size. The wide output voltage range, $0.1 \times V_{VPS} \sim 0.8 \times V_{VPS}$, allows driving one or multiple serial laser diodes at the same time, for up to 25A well controlled current at high efficiency. The extremely low noise between DC~10Hz and low DC current drift make it ideal for driving high current laser diode arrays. Because of the high efficiency, the build-in small heat sink is sufficient to dissipate the heat generated by the driver, no additional heat sink is needed. The fully shielded case blocks all the incoming and outgoing EMIs (Electro-Magnet Interferences). Therefore, this laser will not interfere other surrounding electronics, nor will be interfered by them. The small foot print of this laser driver saves valuable space for the laser system. Figure 1 shows physical photo of the ATLS25A219GUI.

This laser driver has two current set ports which can digitally be controlled to switch between them for setting the output current. This feature allows modulating the laser digitally with 2 preset current values.

The actual laser current and laser driver temperature is monitored by dedicated port. In case the laser driver temperature

exceeds the limit, 120°C, the laser driver will shut down the output stage by itself and force the laser drive into Standby Mode. There is a loop good indication output to tell if the laser driver works well.

The laser driver has 3 states: Operation, Standby and Shutdown. Under Standby mode, all the laser driver components will be working except the output stage, see Figure 7. Under Shutdown mode, all the components of the laser driver stop working and the power supply current is reduced to < 2mA.

This laser driver generates a high accuracy high stability low

noise. When outputting 25A to the laser, the noise current is 20 μ A_{P-P}, noise voltage at the output node, LDA, is <2 μ V_{RMS}, output current stability is <100ppm/°C. It comes with a low noise high stability voltage reference which can be used for setting the output current and also be used as the reference voltage for the ADCs (Analog to Digital Converters) and/or DACs (Digital to Analog Converters).

For noise sensitive applications, please be aware that this laser driver has very low noise between DC to 10Hz, but there is a 500kHz sine-wave ripple voltage, around 10mVpp, present at the output, the LDA port.

Communication function

Utilizing serial port communication, Single Chip Micryoco sends data to computer through USB serial communication interface. With the data received from the SCM, computer decodes the data to get the real-time status of SCM control system. Then the computer will show the user window procedure which is made by the windows.

The following is the computer control interface with parameters:

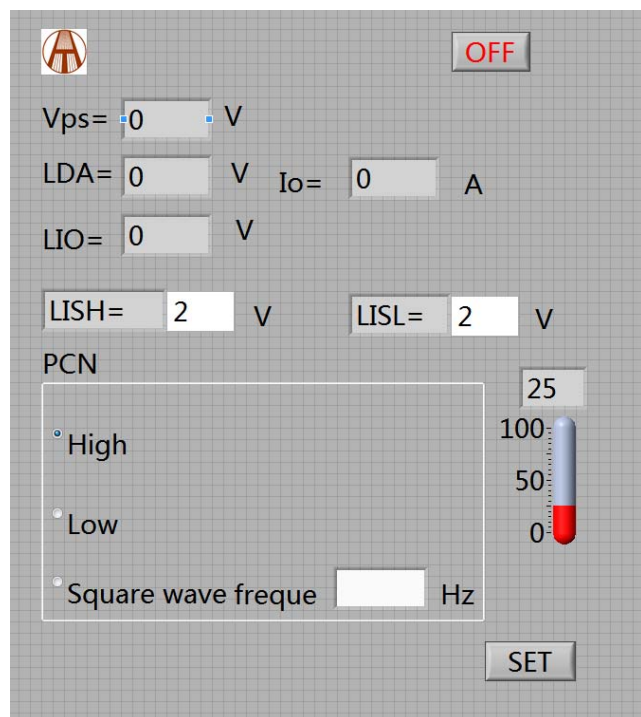

Figure 5. Computer Control Interface

As shown in Figure 14, the power terminals above the controller are VPS, LDPGND, LDC and LDA. As shown in Figure 16, below the controller, from left to right, there are LEDs for loop good indication, Mini USB, Type-C, and controller switch. The controller can be connected to the computer by Mini USB, and the parameters can be set on the computer. It can also be connected to the evaluation board using Type-C, and the parameters can be set by the analog circuit. Whether the parameters are set by the computer or the analog circuit, the data will be displayed on the computer. After setting the parameters, click "OK" and the controller starts to work.

Vps: Power Supply Voltage.

LDA: The voltage of laser

LIO: Laser Current Output Indication. 0V to 4.096V indicates the laser current being from 0 to 25A linearly.

Io: Output current of the laser

LISH: Laser Current High Value Setting Voltage.

LISL: Laser Current Low Value Setting Voltage.

PCN: Pulse Control



Table 1. Pin Function Descriptions

Terminal Block	Pin #	Name	Type	Description
Terminal	1	VPS	Power Input	Power Supply Voltage. The driver works from $V_{VPS}=12V\sim 40V$. The maximum current can go up to 25A.
	2	PGND	Power Input	Power Ground Pin. Connect this pin directly to power supply return path line, 0V. The maximum current on this pin can go up to 25A.
	3	LDC	Analog Output	LDC Pin. Connect it to laser diode cathode terminal. The maximum current on this pin can go up to 25A.
	4	LDA	Analog Output	Laser Diode Anode. Connect it to the laser diode anode terminal. The maximum current of this pin can go up to 25A. When doing layout, do not use a thin and long PCB track, otherwise, the inductance might be too high and oscillation may occur.
Mini USB	5	4VR	Analog Output	It connects the controller to the computer.
	6	GND	Analog Output	
	7	TXD	Analog Output	
	8	RXD	Analog Output	
Type C	9	4VR	Analog Output	Voltage Reference 4.096V output. It can source and sink up to 10mA output current, with a very low $5\mu V_{P-P}$ noise between 0.1 to 10Hz and $< 6ppm/^{\circ}C$ stability. Under Standby Mode, this pin is still working.
	10	GND	Signal Ground	Signal Ground Pin. Connect ADC and DAC grounds to here. When using POTs (potentiometer) to set the output currents, connect the ground terminal of the POTs to here. See Figure 9.
	11	LISH	Analog Input	Laser Current High Value Setting Voltage. For this pin, everything is the same as above except that this pin sets the output current when PCN, pin 7 is high.
	12	LISL	Analog Input	Laser Current Low Value Setting Voltage. There is a $10M\Omega$ input resistor tied to GND. Setting it from 0V to 4.096V will set the laser lower current from 0 to 25A linearly. The current set by this pin can be higher than the current set by the LISH port on pin 2, the reason calling it "low" is because when PCN, pin 13, is low, the laser driver will output the current set by this pin. The input bias current of this pin is $< 0.1\mu A$, in addition to the $10M\Omega$ resistor tied to GND. The maximum input voltage on this pin is 4.096V. It is recommended to use the 4VR port, pin 9, as the voltage source for setting the output current.
	13	PCN	Digital Input	Pulse Control Input. This pin toggles the laser output current to change between two pre-set values: a low value set by the LISL pin @ $V_{PCN} = 0V \sim 0.4V$ and a high value set by the LISH pin @ $V_{PCN} = 1.4V \sim 5V$. This PCN pin is pulled high to an internal 5V rail by an internal $1M\Omega$ resistor and there is a serial $20k\Omega$ resistor between PCN and the electronic switch, see Figure 6. Between 0V ~5V, the pull up resistor causes most of the current on this pin, the electronic switch input current is $< \pm 1\mu A$. The maximum voltage on this pin is 40V, at which the pull down current will be caused by the serial $20k\Omega$ clamped by an over voltage protector of 5V, the current will be $(40V - 5V)/20k\Omega = 1.75mA$. The rise and fall time of the output is 28 μS when PCN pin is switched.
	14	SBDN	Analog/ Digital Input	ON, Standby and Shutdown Control.



Note: Other pins will be displayed on the computer.

Table 2. Temperature vs. V_{TMO} (V) by Different Equations

Temperature (°C)	V_{TMO} (V) by using a regional equation (2)	V_{TMO} (V) by using an approximating equation(4)
-40	2.5420	2.5811
0	2.1231	2.1371
25	1.8557	1.8596
40	1.6931	1.6931
80	1.2520	1.2491
100	1.0272	1.0271
125	0.7424	0.7496

SPECIFICATIONS

Table 3. Characteristics ($T_{AMBIENT}= 25^{\circ}C$)

Parameter	Symbol	Conditions	Min.	Typ.	Max.	Units
Power Supply Input: VPS pin, pin 1						
Input Range	V_{VPS}		12		40	V
Output current	A		0		25	A
Laser Current Setting Voltage: LISH pin and LISL pin, pin 11&12						
Laser current control signal			0		4.096	V
Control accuracy				± 0.1		%
Voltage Reference: 4VR pin, pin 9						
Reference output voltage			3.996	4	4.004	V
Laser Diode Anode: LDA pin, pin 4						
Output voltage range		Frequency is 500kHz	$0.1 * V_{VPS}$		$0.8 * V_{VPS}$	
Standby and Shutdown Control: SBDN pin, pin 14						
Start-up time upon releasing the SBDN pin above 2.7V				20		ms
Shutdown time upon pulling the SBDN pin down				20		μs
Power efficiency		$I_{OUT}=25A, V_{LDA}=30V$ & $V_{VPS}=40V$		90		%
Low frequency output current noise		Peak-to-peak value, 0.1Hz to 10Hz		<20		μA_{P-P}
Stability		25A&-20°C~80°C		< ± 0.2		%
		25A&-20°C~80°C		< ± 20		mA



Standby current			8		mA
Shutdown current			<2		μA
Operating case temperature			-40~110		°C
Operating ambient temperature			-40~85		°C

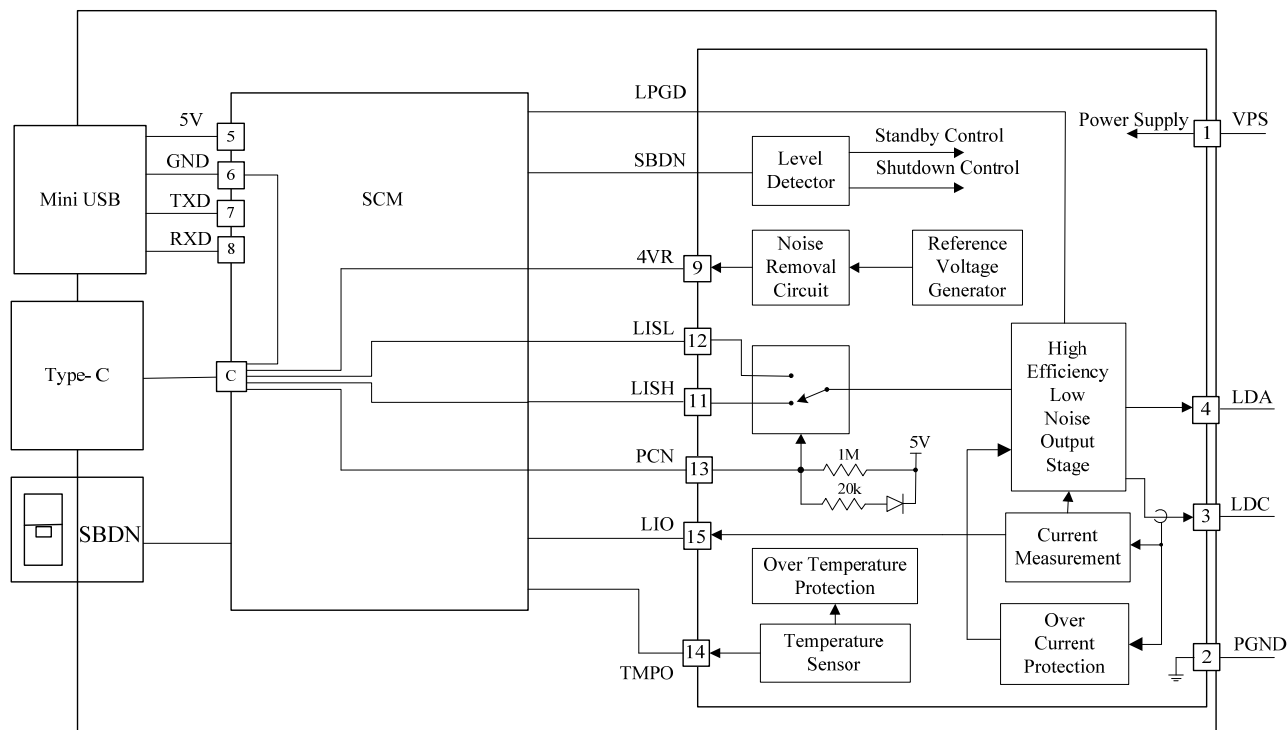

Figure 6. Internal Block Diagram of ATLS25A219GUI



OPERATION PRINCIPLE

The block diagram of the driver is shown in Figure 6. The signal from pin 14, SBDN, is sent to a level detector circuit. As shown in Figure 7, upon detecting signal level between 0V to 2V, the shutdown output is activated; it shuts down the whole laser driver and drives the laser driver into Shutdown Mode; upon detecting the level to be between 2.2V and 2.4V, the standby signal is activated, it put the controller into Standby Mode; when the signal is between 2.7V and above, the controller is driven to Operation Mode.

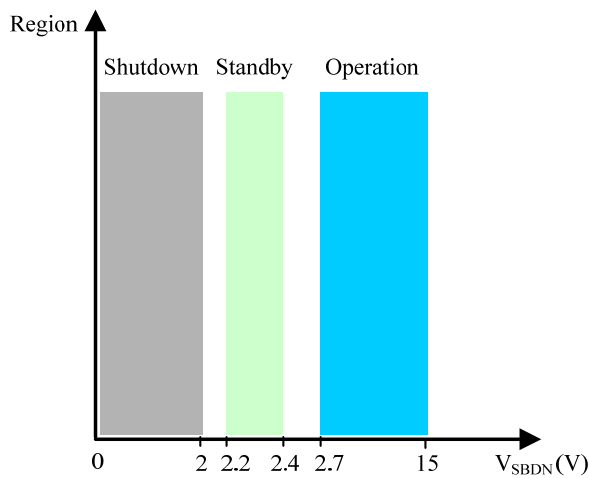

Figure 7. Input Control

At pin 14, TMPO, its value comes from a temperature sensor. The voltage at this pin reflects the internal temperature of this driver. The relationship between the output voltage and the temperature is shown in Figure 8.

There is a temperature protection circuit, upon detecting the temperature to be >120°C, it will force the laser driver into Standby Mode. The laser driver reinitiates the power up sequence when the junction temperature drops below 110°C.

The voltage reference circuit provides internal voltage reference for the driver, its output is taken out after a noise removal circuit at 4VR port, pin 9.

At pin 12 and pin 11, there are 2 ports for controlling the output current: LISL and LISH. The former sets the output current when PCN, Pulse Control, pin 13, is at low level, 0V to 0.4V; the latter sets the output current when PCN pin is at high level, 1.4V to 15V.

On PCN, pin 13, there is a 10M resistor tied to 5V. Therefore, if leaving this pin open, it is set to 5V, a high logic level, thus, LISH is in control. There is a 20kΩ resistor in series with a diode, connected between PCN pin and the 5V internal voltage. When the PCN pin voltage is above 5V, the 20kΩ resistor pulls down the current on PCN pin. The circuit is shown at Figure 6. The waveforms of LISH, LISL, PCN and LIO are shown in Figure 9.

Both LISH and LISL pin set the output current without any offset voltage. The relationship between the voltage and the output current is:

$$I_{OUT} = V_{LISH}/4.096 \times 15 \text{ (A)} = 3.662 \times V_{LISH} \text{ (A)}, \text{ or}$$

$$I_{OUT} = V_{LISL}/4.096 \times 15 \text{ (A)} = 3.662 \times V_{LISL} \text{ (A)};$$

$$V_{LISH} = I_{OUT} \text{ (A)} / 15 \times 4.096 = 0.273 \times I_{OUT} \text{ (A)}, \text{ or}$$

$$V_{LISL} = I_{OUT} \text{ (A)} / 15 \times 4.096 = 0.273 \times I_{OUT} \text{ (A)},$$

Where I_{OUT} is the output current of the laser driver, V_{LISH} or V_{LISL} represents the voltage on the LISH or LISL pin respectively, in volt.

The LIO port, pin 15, outputs an analog voltage that is proportional to the actual output current. When the output current is 0A, the LIO voltage is 0.1V; when output current is 15A, the LIO voltage is 2.5V. The relationship is:

$$V_{LIO} = I_{OUT} \text{ (A)} / 15 \times 4.096 = 0.273 \times I_{OUT} \text{ (A)};$$

$$I_{OUT} = V_{LISL} / 4.096 \times 15 \text{ (A)} = 3.662 \times V_{LISL} \text{ (A)};$$

V_{LIO} is the voltage on the LIO pin.

The waveform of LIO vs. LISH, LISL and PCN is shown in Figure 12.

The output stage is designed to achieve low noise, high efficiency, and relatively high modulation speed. It has an over current protection circuit. There is a soft start circuit which increases the output current slowly at the start up time and shuts down the current quickly.

The LPGD pin indicates the control loop status. When this pin goes high, >2V, the control loop is working properly, i.e., the output current equals to the desired value, LISH or LISL = LIO voltage; when this pin goes low, <0.3V, the laser driver is not working properly, there might be a short or open circuit at the output, or the laser driver is protected by the over temperature protection circuit.

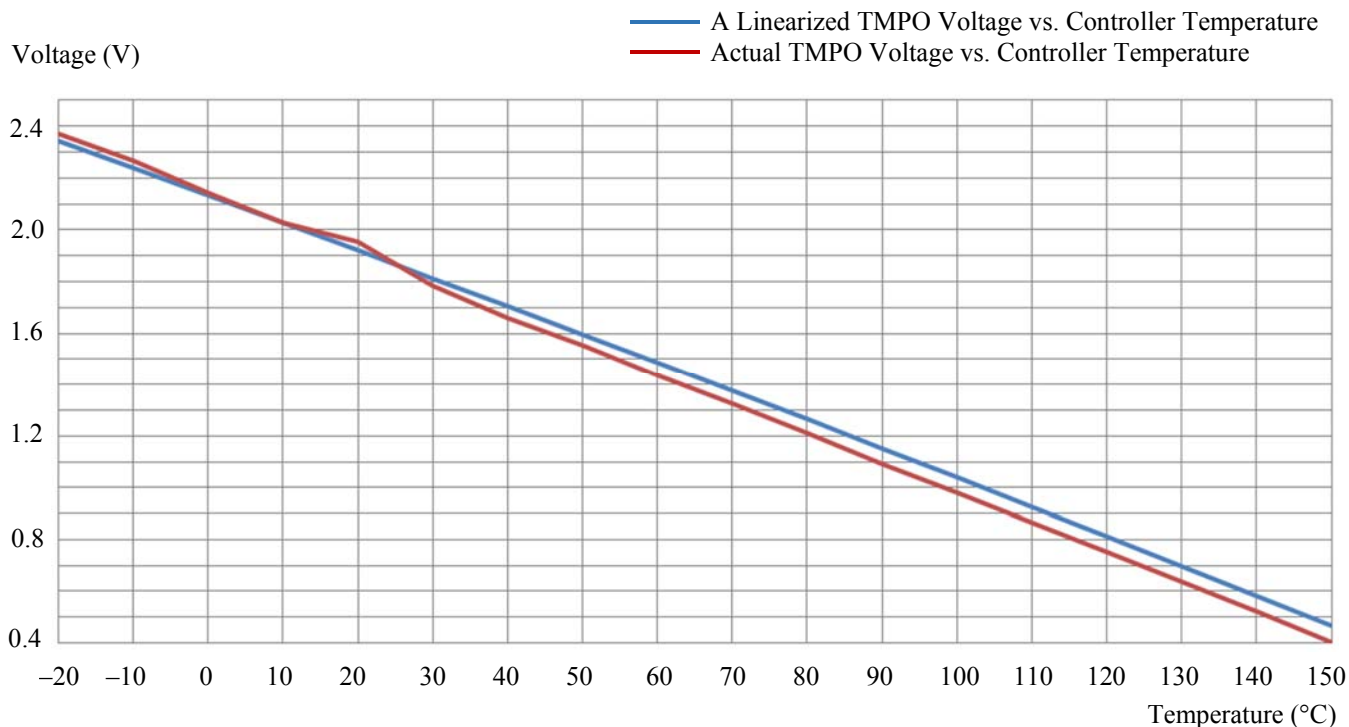

Figure 8. Controller Internal Temperature vs. TMPO Voltage

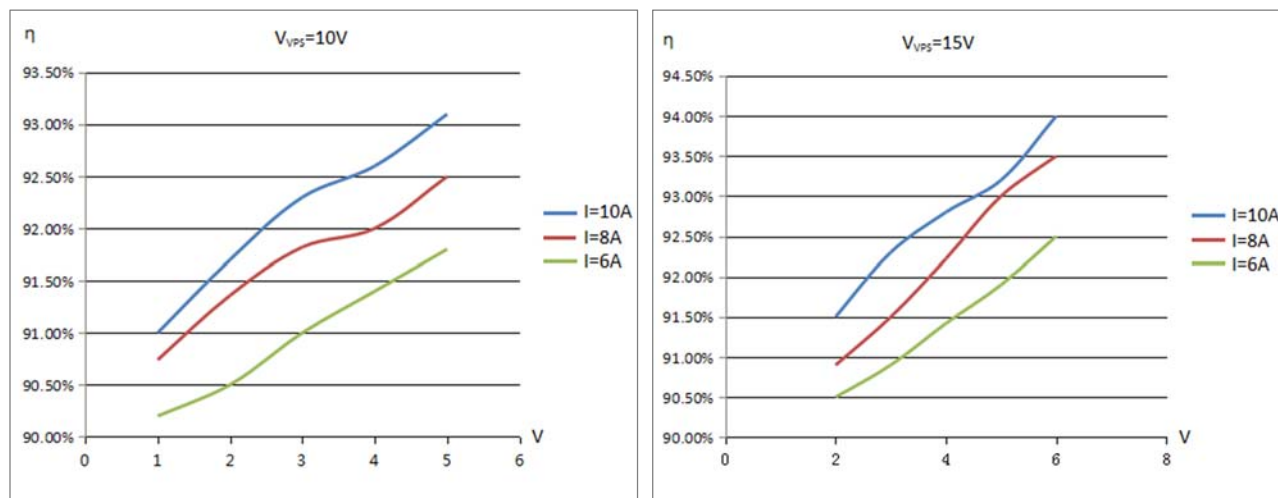

Figure 9. Efficiency of Laser Driver



APPLICATION INFORMATION

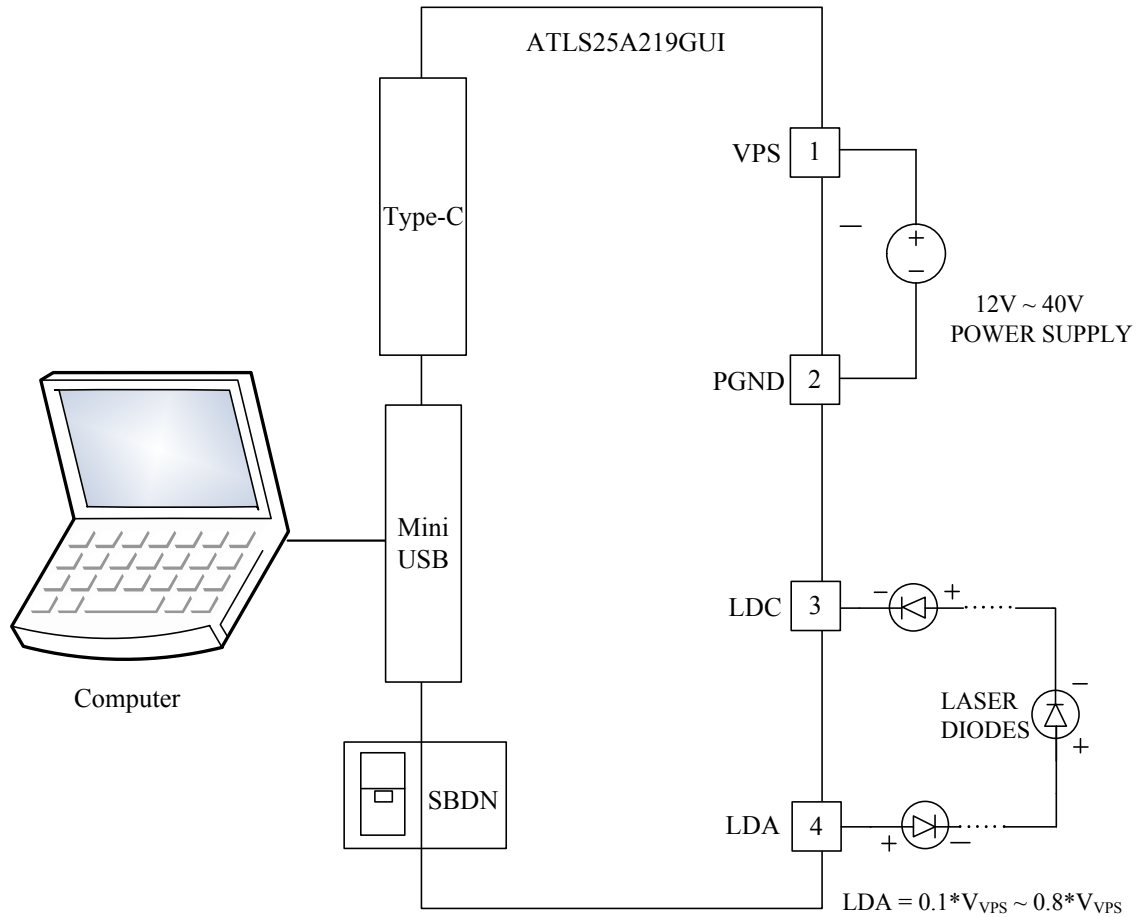

Figure 10. Stand-Alone Application Schematic

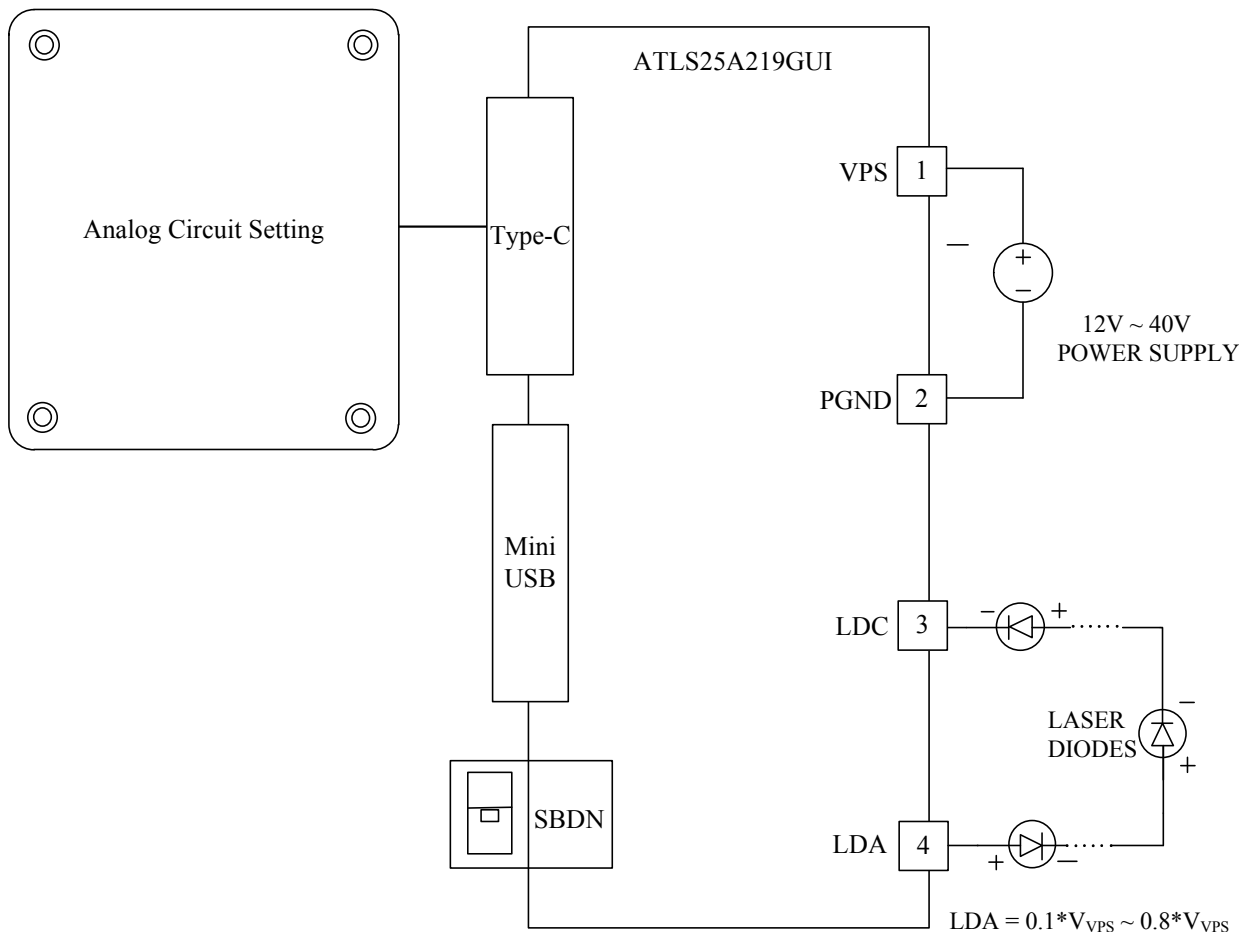

Figure 11. Micro-Controller Based Application Schematic

Figure 10 shows a typical stand-alone application circuit. Figure 11 shows a micro-controller based application schematic.

Table 4 shows the relationship between Digital D1, D2, and laser driver state. Refer to Figure 11.

Table 4.

Digital Output D1	Digital Output D2	Laser Driver State
0	0	Shutdown
0	1	Standby
1	0	Note
1	1	Operation

Note: For the input state D1=1 and D2=0, the controller's state is depending on the output voltage at SBDN pin:

$$V_{SBDN10} = \frac{R2}{R1 + R2} \times V_D$$

$$V_{SBDN01} = \frac{R1}{R1 + R2} \times V_D$$

Where, V_D is the logic1 output voltage for D1 & D2 signals.

Digital signal V1 and V2 control the laser driver into Shutdown, Standby or Operation mode. The starting up time delay is about 20mS and the shut down time is about 20μS.

It is worth mentioning that to achieve high speed and low distortion digital modulation, one can use the LISL pin to set a current that is a little lower than the threshold current of the laser diode to turn off the laser beam, such as half of its value, use the LISH pin to set the laser current when the laser diode is turned on. In this way, the laser beam is turned on and off, while the driver control loop is always kept on, so that the output stage is always under control, not distortion is caused by turning on/off the output stage.

When no modulation is needed, one can leave PCN unconnected; LISL pin connects to GND, and use LISH to set the output current.

In Figure 10, the LED is used to indicate laser diode status. When LDGD pin is high, > 2V, the laser diode control loop is



working properly. When LPGD pin is low, <0.3V, the laser diode control loop is not working properly, there might be a short or open circuit at the laser diode, or the laser driver is put into Standby or Shutdown mode. The LPGD pin can also be connected to a digital input pin of a micro-driver, when software/firmware is utilized in the system. See Figure 11. The equivalent circuit of this pin is a 3kΩ resistor pulling it up to 4.5V rail and an open drain FET, 500Ω, pulling it down to the ground. The pull-up current can be increased by

connecting an external pull-up resistor between LPGD and VPS. Tie this added additional pull up resistor to a 3.3V or 5V power supply if they are available. Make sure that the pull up current is not too high, otherwise, the internal open drain FET cannot pull-down the LPGD pin low enough to turn off the LED.

The laser diodes are connected between LDA and LDC pins. It is worth mentioning that the power supply return terminal should be connected to the pin 3 LDC.

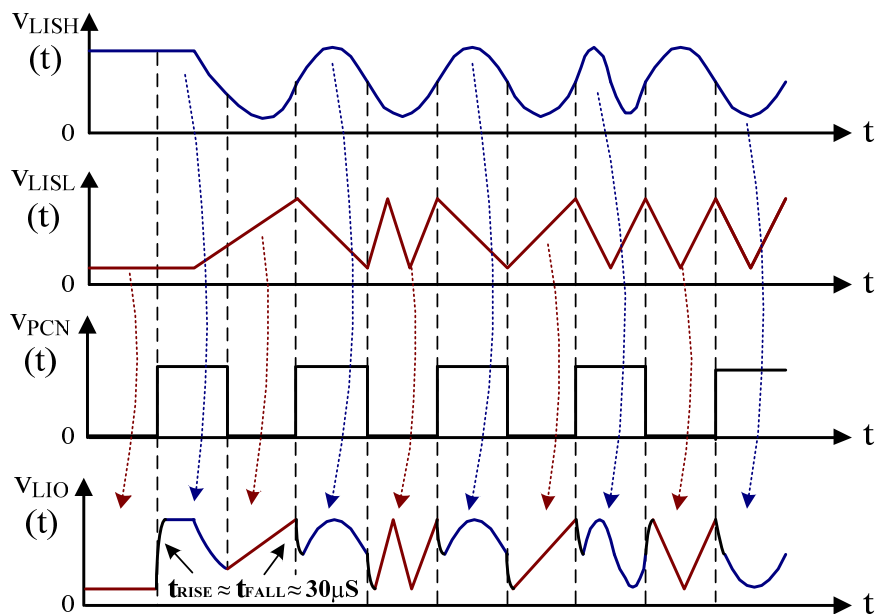

Figure 12. Digitally Controlled Analog Modulation Principle

Turning on/off the Controller

The driver can be turned on and off by setting the SDBN pin high and low respectively. It is recommended to turn the driver on by this sequence:

To turn on: turn on the power by providing the power supply voltage to the driver on VPS pin, turn on the driver by releasing the SDBN pin.

To turn off: turn off the driver by lowering the voltage of SDBN pin, turn off the power by stopping the voltage supply on the VPS pin.

When not controlling by the SDBN pin: leave it unconnected and turn on and off the driver by the power supply.

Adjusting the Output Current

The output current is set by adjusting W1, which sets input voltages of LISL and LISH. See Figure 10. The output current will be:

$$I_{OUT} = 3.662 \times V_{LISL} \text{ or } 3.662 \times V_{LISH} \text{ (A)}$$

LIS can also be set by using a DAC to replace the W1 in Figure 10. Make sure that the DAC has low output noise.

Monitoring the Output Current

The output current of the driver can be monitored by measuring the voltage on the LIO pin. This feature is very useful for micro-driver based system where the ADC is available and monitoring the current in real time is required. This pin provides a very low noise voltage signal and is proportional to the output current:

$$I_{OUT} = 3.662 \times V_{LIO} \text{ (A)}$$

For example, when the output signal is 4.096V, the output current is 25A.

LIO can be used to drive an ADC directly, and also be measured by a multi-meter.

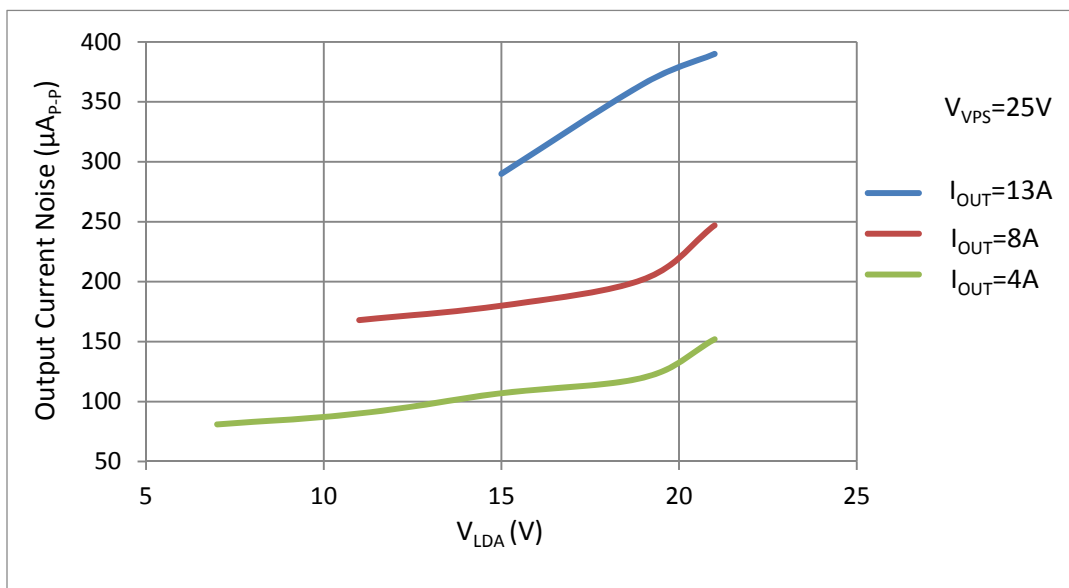

Figure 13. V_{LDA} vs. Output Current Noise@0.1Hz~10Hz

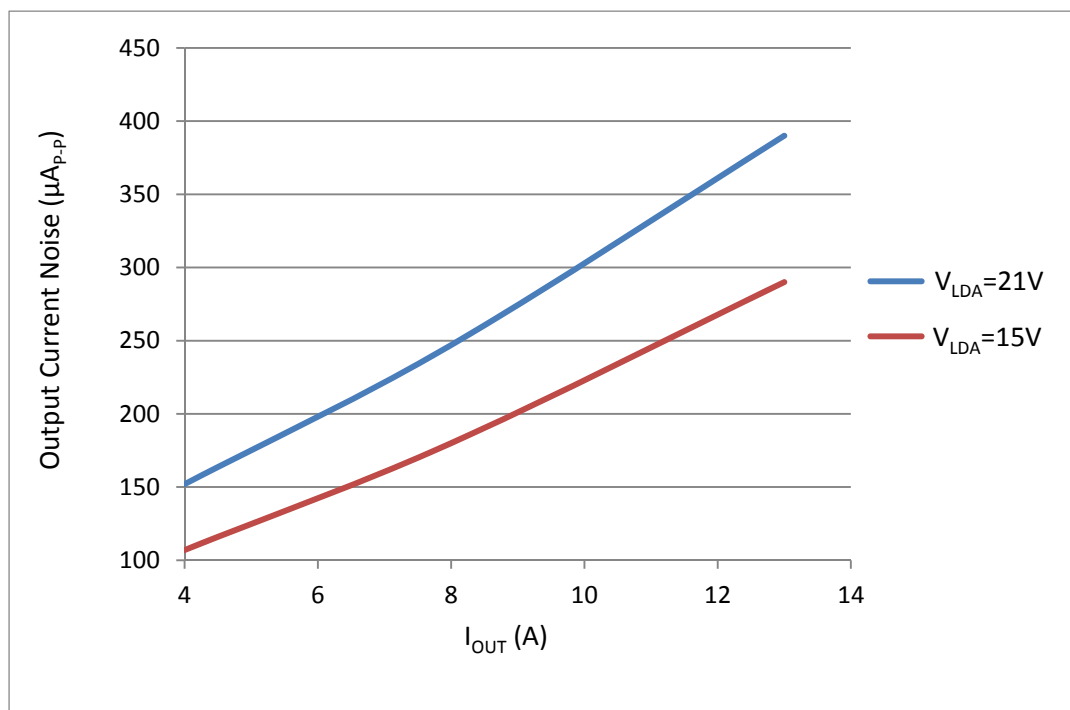

Figure 14. I_{OUT} vs. Output Current Noise@0.1Hz~10Hz

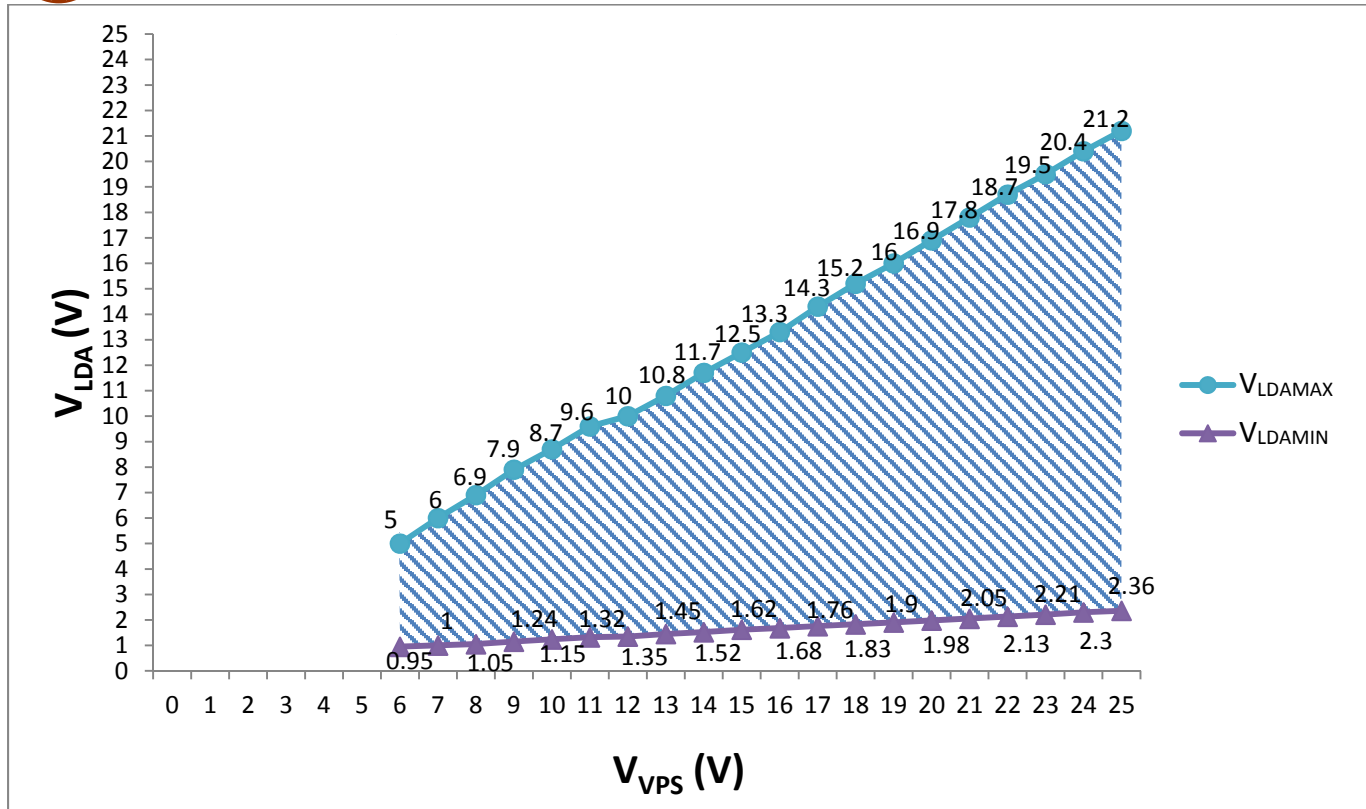

Figure 15. V_{VPS} vs. V_{LDA}

First Time Power Up

Laser diode is a high value and vulnerable device. Faults in connections and damages done to the driver during soldering process may damage the laser diode permanently. To protect the laser diode, it is highly recommend to use 3 to 18 regular diodes which is >15A to form a “dummy laser” and insert it in the place of the real laser diode, when powering up the driver for the first time. Use an oscilloscope to monitor the LDA voltage at times of powering up and enabling the shutdown pin, and powering down the laser driver and turning off the shutdown pin, and make sure that there is not over-shoot output voltage at the LDA pin. At the same time,

it uses an ammeter in series with the dummy laser, to make sure that the output current is correct. After thoroughly checking and making sure of free of faults in the system, disconnect the dummy laser diode and connect the real laser diode in place. The driver output voltage range for the laser is between 0.1V_{VPS}to 0.8V_{VPS} (power supply input voltage).

Warning: Both the surface mount and the through hole types of packages can only be soldered manually on the board by a solder iron of < 310°C (590°F), do not use a reflow oven to solder this laser driver.

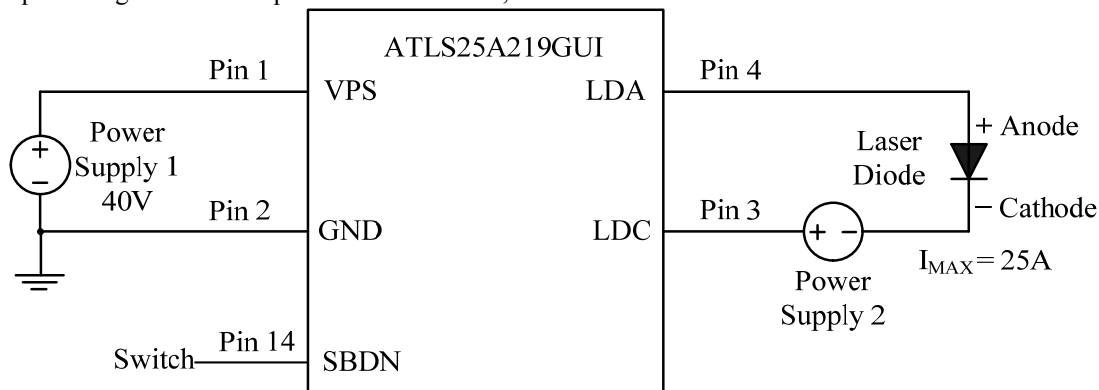

Figure 16. Driving High Voltage Laser Diodes



Warning: To turn on the laser, firstly turn on Power Supply 2 and Power Supply 1 while keeping SBDN=0, after $\geq 100\text{ms}$, then turn on the laser driver ATLS25A219GUI by using the SBDN pin. To turn off the laser, firstly turn off the laser driver ATLS25A219GUI by driving the SBDN pin to Standby or Off State, then turn off the Power Supply 2 and 1.

OUTLINE DIMENSIONS

The controller is chassis mounted, with good heat dissipation performance, and can work under high power without adding heat sink. Dimensions of this controller is shown in Figure 17.

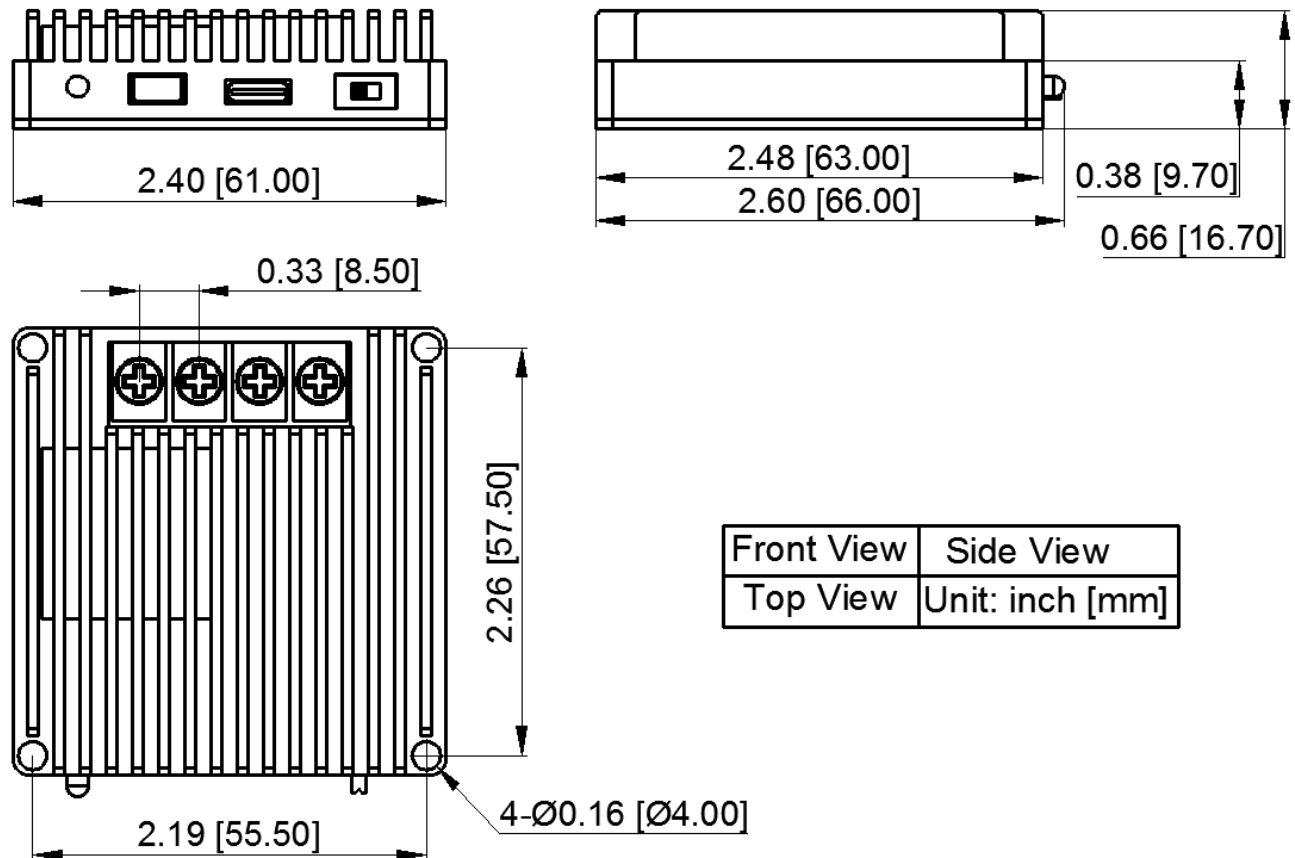

Front View	Side View
Top View	Unit: inch [mm]

Figure 17. Dimensions of ATLS25A219GUI

ORDERING INFORMATION

Table 5. Part Number

Part Number	Description
ATLS25A219GUI	25A constant current laser driver with a GUI interface

Table 6. Unit Price

Quantity (pcs)	1 – 9	10 – 49	50 – 199	200 – 499	500-999	≥ 1000
Unit Price	\$289	\$279	\$269	\$249	\$229	\$199



NOTICE

1. ATI warrants performance of its products for one year to the specifications applicable at the time of sale, except for those being damaged by excessive abuse. Products found not meeting the specifications within one year from the date of sale can be exchanged free of charge.
2. ATI reserves the right to make changes to its products or to discontinue any product or service without notice, and advise customers to obtain the latest version of relevant information to verify, before placing orders, that information being relied on is current and complete.
3. All products are sold subject to the terms and conditions of sale supplied at the time of order acknowledgment, including those pertaining to warranty, patent infringement, and limitation of liability. Testing and other quality control techniques are utilized to the extent ATI deems necessary to support this warranty. Specific testing of all parameters of each device is not necessarily performed, except those mandated by government requirements.
4. Customers are responsible for their applications using ATI components. In order to minimize risks associated with the customers' applications, adequate design and operating safeguards must be provided by the customers to minimize inherent or procedural hazards. ATI assumes no liability for applications assistance or customer product design.
5. ATI does not warrant or represent that any license, either express or implied, is granted under any patent right, copyright, mask work right, or other intellectual property right of ATI covering or relating to any combination, machine, or process in which such products or services might be or are used. ATI's publication of information regarding any third party's products or services does not constitute ATI's approval, warranty or endorsement thereof.
6. IP (Intellectual Property) Ownership: ATI retains the ownership of full rights for special technologies and/or techniques embedded in its products, the designs for mechanics, optics, plus all modifications, improvements, and inventions made by ATI for its products and/or projects.