



Figure 1. Physical Photo of ATLS200MA103S

FEATURES

- Ultra Low Noise: $2.5\mu A_{p-p}$ @ 0.1Hz to 10Hz
- High Current without Heat Sink: 200mA
- High Absolute Accuracy: $<0.1\%$
- High Stability: $<100ppm/^{\circ}C$
- Programmable Current Limit
- Complete Shielding
- Compact Size
- 100 % Lead (Pb)-free and RoHS Compliant
- DIP and SMT Packages Available

APPLICATIONS

Driving laser diodes with low noise, including DPSSL, EDFA, SOA, fiber laser, direct diode lasers, etc.

DESCRIPTION

The ATLS200MA103 is an electronic module designed for driving diode lasers with up to 200mA low noise current. Figure 1 shows physical photo of ATLS200MA103. The output voltage is 0.4V to $V_{VPS} - 1V$ when powered by a 5V power supply.

When the maximum power consumed by the controller is maintained to $<1W$, it does not require a heat sink to operate. The controller has temperature compensation network so that the output current maintains the same even as the controller temperature rises.

Table 1. Pin Function Descriptions

Pin #	Pin Name	Pin Type	Description
1	SDN	Digital input	For ATLS200MA103: Shut down control. Negative logic. When the voltage is $<0.7V$, shutdown on; when the voltage is $>1V$, shutdown off. For ATLS200MA103-PD: Shut down control. Positive logic. When the voltage is $<0.7V$, shutdown on; when the voltage is $>1V$, shutdown off. There is a pull-down resistor of 100k to the ground.
2	GND	Signal ground	Signal ground pin. Connect ADC and DAC grounds to here.

In case the controller temperature exceeds a preset limit, $120^{\circ}C$, the controller will be shut down by itself to prevent the controller from being damaged by the over heat.

The output current of the ATLS200MA103 can be set by an input voltage linearly or modulated by an external large signal of up to 1MHz in bandwidth, resulting in a minimum 170ns rise and fall times (Large signal) at the output current.

A highly stable low noise 2.5V reference voltage is provided internally for setting the output current. This reference can also be used as the voltage reference for external ADCs (Analog to Digital Converters) and/or DACs (Digital to Analog Converters) which are utilized for converting the analog signals, such as LIO which represents the output current, into digital signals, and/or converting the digital signals into analog ones for setting the analog voltages, such as LIS which sets the output current.

The ATLS200MA103 is packaged in a 6 sided metal enclosure, which blocks EMIs (Electro-Magnetic Interferences) to prevent the controller and other electronics from interfering each other.

This laser driver can be evaluated by our evaluation board, [ATLS1A103DEV1.0](#).

There are 2 packaging versions available: DIP through hole package and surface mount type.

Warning: Both the surface mount and the through hole types of modules can only be soldered manually on the board by a solder iron of $<310^{\circ}C$ ($590^{\circ}F$), not go through a reflow oven process.

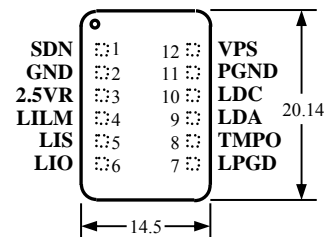

Figure 2. Pin Names and Locations

Figure 2 is the actual size top view of the ATLS200MA103, which shows the pin names and locations. Its thickness is 5mm. Table 1 shows the pin function descriptions.



3	2.5VR	Analog output	2.5V reference voltage. It is used by the internal DACs as the reference voltage. It can source 3mA max, with 5µVp-p noise @ 0.1Hz to 10Hz and 25ppm/°C stability max.
4	LILM	Analog input	Laser current limit set. 0V to 2.5V sets the laser current limit from 0 to 220mA linearly.
5	LIS	Analog input	Laser current set. 0V to 2.5V sets the laser current from 0 to 200mA linearly.
6	LIO	Analog output	Laser current output indication. 0V to 2.5V indicates the laser current from 0A to 200mA linearly.
7	LPGD	Digital output	Loop good indication. When the controller is working properly, this pin is pulled high. Otherwise, it is pulled low.
8	TMPO	Analog output	The driver internal temperature indication output. Operating internally temperature.
9	LDA	Analog output	Laser diode anode. Connect it to the anode of the laser diode. This pin is used to drive a laser of which the cathode is connected to the case and the case is connected to the ground. Make sure $V_{LDA} > 0.8V$. See below Figure 4.1, 4.2 or Figure 7.
10	LDC	Analog output	Laser diode cathode. Only connect to the cathode of the laser diode. See below Figure 4.1, 4.2 or Figure 7.
11	PGND	Power ground	Power ground pin. Connect it directly to power supply return rail.
12	VPS	Power input	Power supply. The driver works from 3.8V to 5.5V.

SPECIFICATIONS

Table 2. Characteristics ($T_{ambient} = 25^{\circ}C$)

Parameter	Value	Unit
Maximum output current	200	mA
Output current noise (0.1Hz to 10Hz)	≤ 2.5	μA_{p-p}
Current set voltage range	0 ~ 2.5	V
Current limit set voltage range	0 ~ 2.5	V
Minimum drop out voltage	0.43V@ $V_{VPS}=3.1V$	V
	0.45V@ $V_{VPS}=5.5V$	
Power supply voltage range	3.8 ~ 5.5	V
shut down logic voltage threshold voltage	0.5~1.3	V
Operating case temperature	-40 ~ 85	°C
Bandwidth of large signal	1	MHz
Bandwidth of small signal	1.2	MHz
Rise and fall times of small signal	300	nS
Rise and fall times of large signal	170	nS

OPERATION PRINCIPLE

The block diagram of the controller is shown in Figure 3.

The shut down control circuit is activated under one of these 3 circumstances: external shut down, output current exceeds the current limit, and the internal temperature exceeds 120°C.

When the controller is shut down by the external shutdown signal, it will restart upon detecting the releasing of the shutdown signal.

When it is shut down by the over current limit, the controller shuts down itself and restarts again by going through the

soft-start process immediately. Therefore, the output current has a saw-tooth waveform: quick shut down, slow and ramp up.

When the controller is shut down by the over temperature, it will wait till the temperature goes below the temperature limit, 120°C. Usually it takes a few or tens of seconds for the controller to cool down before it restarts itself, depending on the thermal mass of the controller and its surrounding mechanical parts attached thermally, such as the PCB and its traces, the heat-sinks if any, etc.

When controller is shut down, the voltage reference is also shut down.

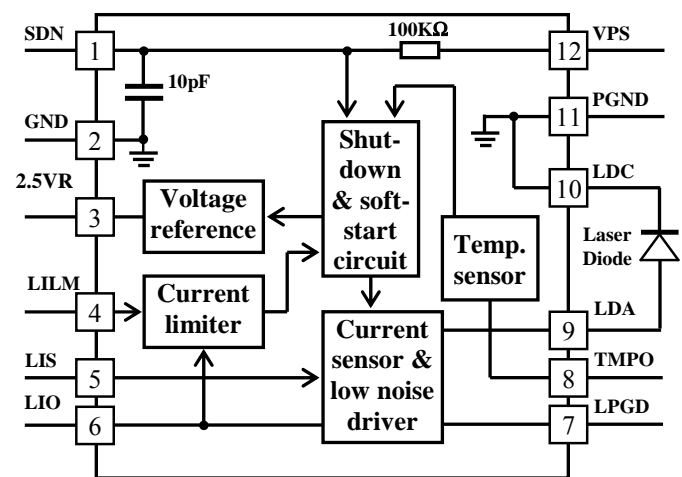

Figure 3. Block Diagram

Note: The Pin 7, LPGD, is pulled down by an open drain MOSFET and pulled up by a 5k resistor tied to VPS rail.

APPLICATIONS

Figure 4.1 and 4.2 show a typical application circuit. W1 and W2 set the output current limit and output current respectively. Resistor R1 and capacitor C1 form a low pass filter, to lower the noise from the voltage reference.

Laser diode D1 is connected between LDA and PGND. It is worth mentioning that the power supply return terminal should be connected to the pin 11 PGND and the cathode of the laser diode should be connected to the pin 10 PGND. These 2 nodes should not be connected together externally and they are connected together internally already by the controller.

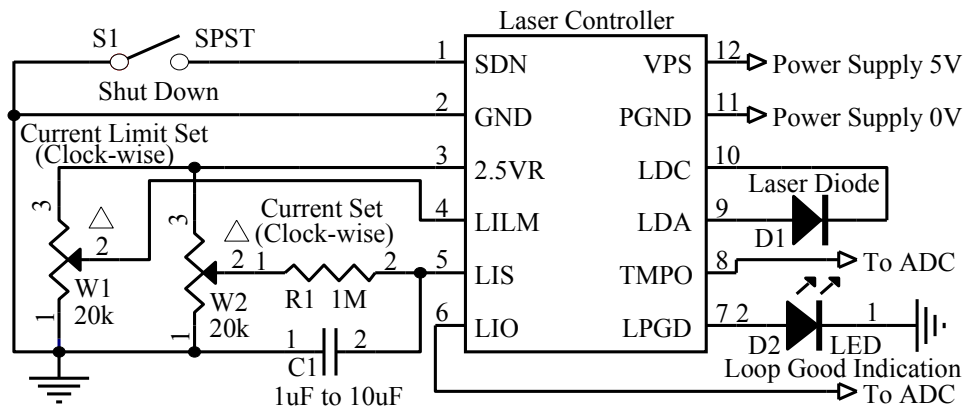

Figure 4.1. Typical Stand-alone CW Operation Schematic for ATLS200MA103

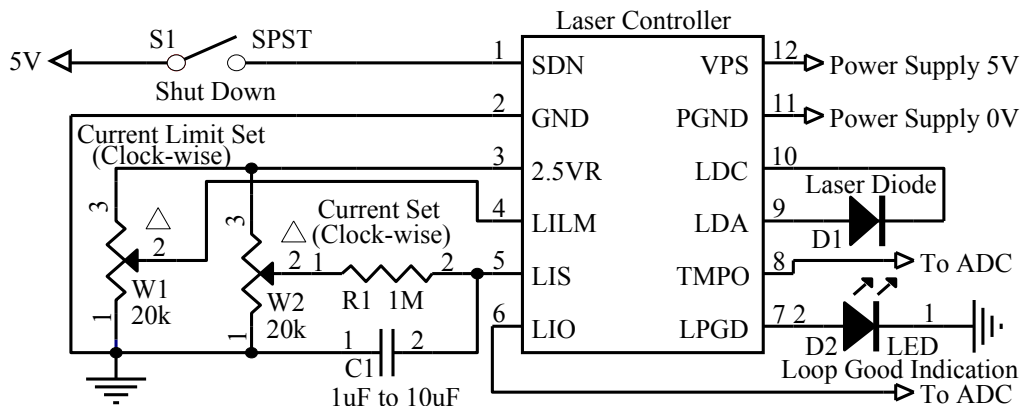

Figure 4.2. Typical Stand-alone CW Operation Schematic for ATLS200MA103-PD

Turning the Controller On and Off

The controller can be turned on and off by setting the SDN pin high and lower respectively. It is recommended to turn the controller on by this sequence:

To turn on: For ATLS200MA103, turn on the power by providing the power supply voltage to the controller, turn on the controller by releasing the SDN pin. For ATLS200MA103-PD, turn on the power by providing the power supply voltage to the controller, turn on the controller by connecting the SDN pin to VPS.

To turn off: turn off the controller by lowering the voltage of SDN pin, turn off the power by stopping the voltage supply on the VPS pin.

When not controlling by the SDN pin: leave it unconnected and turn on and off the controller by the power supply.

In Figure 4.1 and 4.2, S1 is the shut down switch. For

ATLS200MA103, the internal equivalent input circuit of SDN pin is a pull-up resistor of 100k being connected to VPS in parallel with a 10pF capacitor to the ground. For ATLS200MA103-PD, the internal equivalent input circuit of SDN pin is a pull-down resistor of 100k being connected to the ground in parallel with a 10pF capacitor to the ground. The switch S1 can also be an electronic switch, such as an I/O pin of a micro-controller, with an either open drain or push/pull output. If not using a switch (S1) to control the laser, leave the SDN pin unconnected. D2 is an LED, indicating when the control loop works properly, that is: the output current equals to the input set value. This pin has an internal pull up resistor of 5k to the power supply pin, VPS, pin 10. The pull down resistance is 200Ω. This 5k resistor can drive a high efficiency LED directly. When higher pull up current is needed for driving such as a higher current LED, an external resistor can be placed between the VPS and the LPGD pins. Make sure that the resistor is not too small that the pull down resistor will not be able to pull the pin low enough when the controller loop

is not good. When choosing not to use an LED for indicating the working status, leave the LPGD pin unconnected.

The LPGD pin can also be connected to a digital input pin of a micro-controller, when software/firmware is utilized in the system.

Setting the Output Current

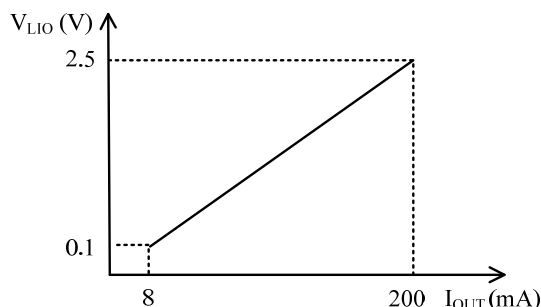

Figure 5. V_{LIO} & I_{OUT}

Figure 5 shows the relationship between V_{LIO} and the output current. When V_{LIO} is 0.1V, the laser driver starts to output the current, 4mA. The condition is $V_{LDA} > 1.2V$.

The output current limit is set by adjusting W1, which sets input voltages of LILM, pin 4. The output current will be:

$$I_{OUT} \text{ (mA)} = 220 \text{ (mA)} \times V_{LILM} \text{ (V)} / 2.5 \text{ (V)}.$$

LILM should never be left float. Otherwise, the output current limit may be set to too high a value that the laser might be damaged.

The output current is set by adjusting W2, which sets input voltages of LIS, pin 5. The output current will be:

$$I_{OUT} \text{ (mA)} = 200 \text{ (mA)} \times LIS \text{ (V)} / 2.5 \text{ (V)}.$$

When no modulation is needed, it is suggested to use an RC low-pass-filter, the R1 and C1 in Figure 4.1, to lower the AC noise from the voltage reference source. The time constant of this filter can be between a few to 10's of seconds. The bigger the time cost, the lower the output noise, but the longer time will be needed to wait the output current to go up.

Both of LILM and LIS, only LIS, can be configured by using a DAC, to replace the W1 and W2 in Figure 4.1. Make sure that the DAC has output low noise, or, if no modulation

is needed, an RC low pass filter by be inserted between the DAC and the LIS pin, similar as shown in Figure 4.1.

The LIS allows modulating the output current by a large signal of up to 1MHz in bandwidth. That is, when using a sine wave signal to modulate the LIS pin, the output current response curve will be attenuated by 3dB, or 0.71 times the full response magnitude in current. When using an ideal square-wave to modulate the output current at the LIS pin, the rise and fall time of the output current will be about 170nS (Large signal).

When the modulation signal is a square-wave and low output noise is require, the low-pass-filter can still be used for lowering the output noise. Figure 7 shows such a circuit. The resistor R1 can be 10k to 1M, depending on the error voltage caused by the switch leakage current. The LILM pin can be set by a POT as shown in Figure 4 or connect to 2.5VR.

It is recommended not to set the LIS pin to 0V, but keep it $> 0.05V$ at all the time. The reason is that the laser diode usually has a junction voltage of 2.5V, when setting the LIS pin voltage to 0V, the output voltage will warble between 0V and 2.5V, cause some oscillation slightly.

The LIO can still be used to monitor the output current when the LIS is modulated. The bandwidth of the LIO signal is $> 10MHz$, more than enough for monitoring output current modulated by the LIS signal.

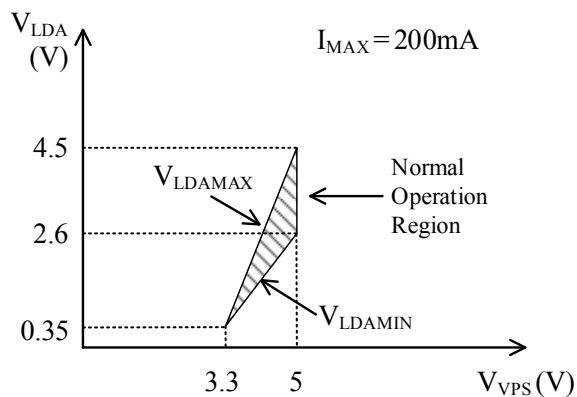

Figure 6. V_{VPS} & V_{LDA}

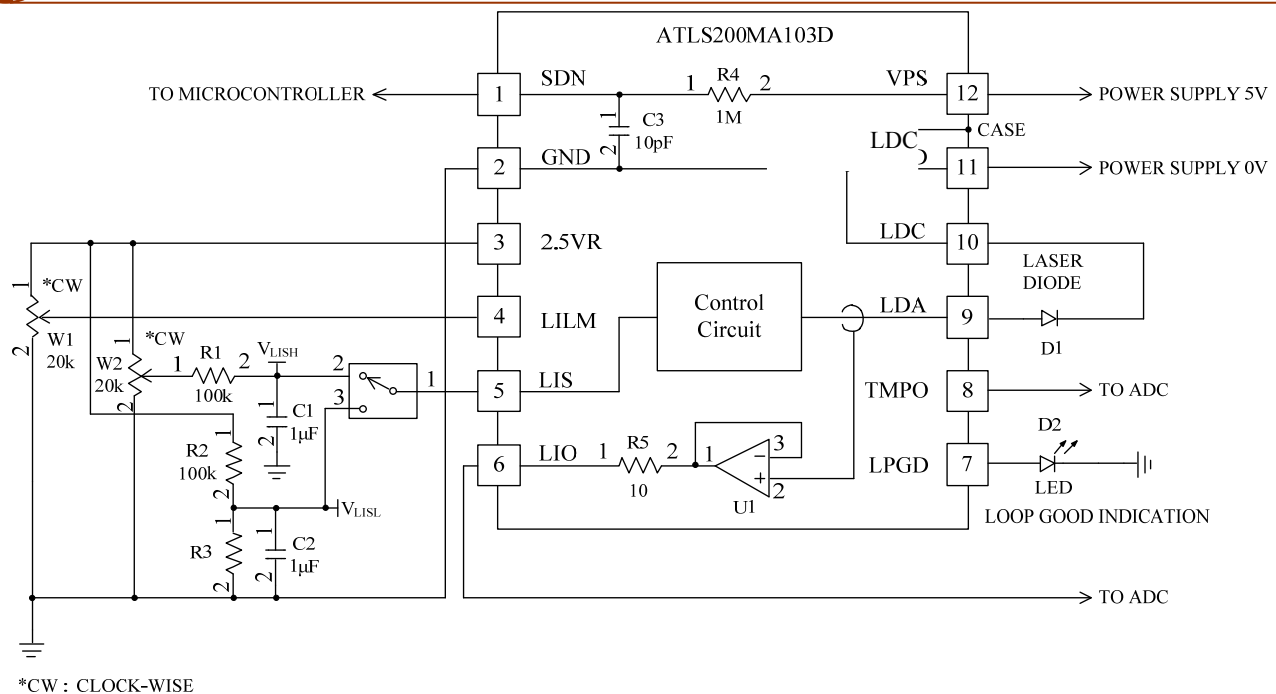

Figure 7. Low Noise Digital Modulation Circuit

Note:

- V_{VPS} : the power supply voltage on VPS pin
- V_{LDAMAX} : the maximum output voltage of LDA pin
- V_{LD} : the forward voltage of the laser diode
- V_{LDH} : the highest forward voltage of the laser diode on the modulation
- V_{LDL} : the lowest voltage of the laser diode on the modulation
- V_{LIOH} : the highest voltage of LIO pin
- V_{LIOl} : the lowest voltage of LIO pin
- P_{OLD} : the optical output power of the laser diode
- P_{OLDH} : the highest optical output power of the laser diode on the modulation
- I_{LD} : the laser diode current
- I_{LDH} : the highest laser diode current on the modulation
- I_{LDL} : the lowest laser diode current on the modulation

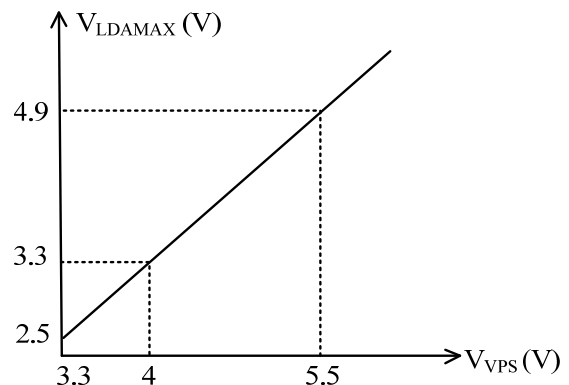

Figure 8. Power Supply Voltage V_{VPS} vs. LDA Pin Maximum Voltage V_{LDAMAX}

Maximum LDA Output Voltage vs. Power Supply Voltage

The maximum LDA pin output voltage is depending on the power supply input voltage, V_{VPS} . Their relationship is shown in Figure 8. Therefore, it is recommended that:

$$V_{VPS} \geq V_{LDAMAX} + 1V,$$

Where V_{LDAMAX} is the laser diode’s maximum possible forward voltage at the operation current.

To Avoid Output Current Distortions

The laser diode’s forward voltage and current has a non-linear relationship shown in Figure 9.1 and 9.1. It can be seen that when the current is low, the voltage is uncertain, it can be between 0V to 1V or more. Thus, when setting the output current to zero, the output voltage will oscillate between 0V



to about 1V or 1.5V, depending on the wavelength of the laser diode. If we set the lowest output current to a non-zero value, such as 1/10 of the laser's operating current but lower than the laser's threshold current, the laser's optical beam can still be cut-off, but the output voltage will not oscillate, thus the output current will not have distortions. The status of the LIO is similar as the Figure 10 shown without output current distortions.

The laser's threshold current is shown in Figure 11. It can be seen that when the laser's current fall below a certain value, there is no output optical power. For example, the operating current and threshold current of a red laser diode of 650nm are 30mA and 20mA respectively and the optical output power is 4mW. It will have no optical output power if the output current of this laser diode is lower than 20mA which is its threshold current. Figure 12 and Figure 13 will describe you the relationship between the I_{LD} and P_{LD} .

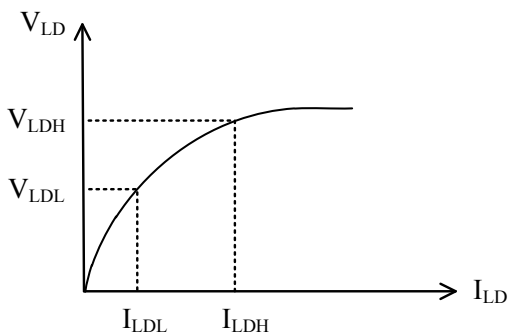

Figure 9.1. Laser Diode Current I_{LD} vs. Laser Diode Voltage V_{LD}

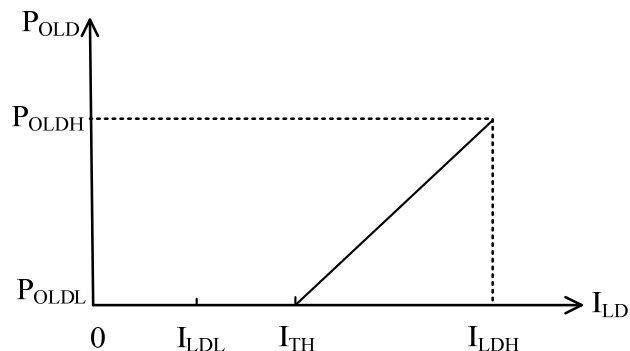

Figure 11. Laser Diode Current I_{LD} vs. Laser Diode Optical Power P_{OLD}

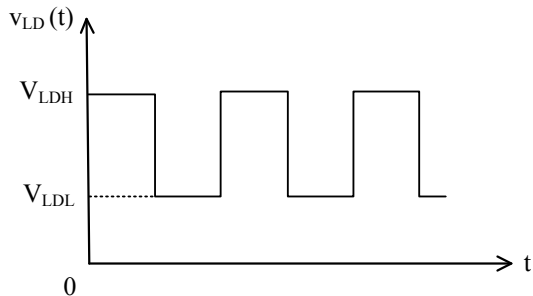

Figure 9.2. Laser Diode Voltage $v_{LD}(t)$ Waveform

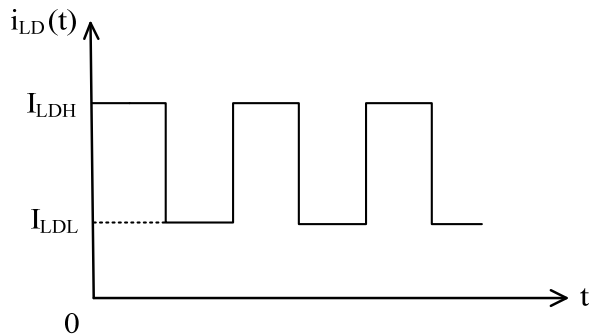

Figure 12. Laser Diode Current i_{LD} Waveform

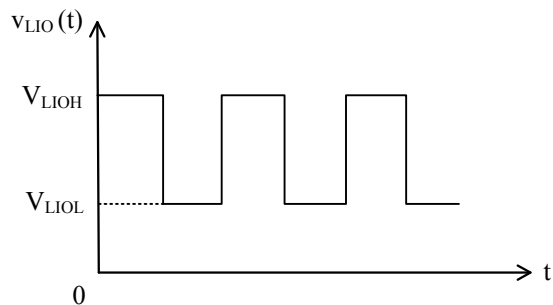

Figure 10. LIO Pin Voltage $v_{LIO}(t)$ Waveform

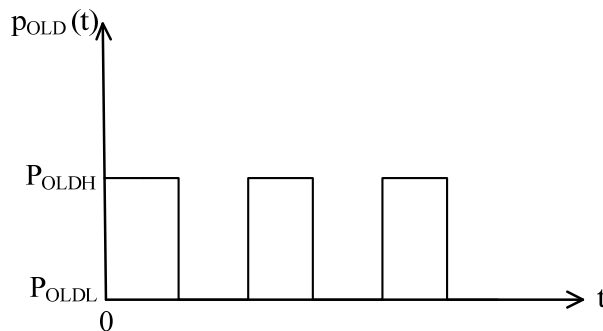

Figure 13. Laser Diode Optical Power P_{OLD} Waveform

Monitoring the Output Current

The output current of the controller can be monitored by measuring the voltage on the LIO pin. This feature is very useful for micro-controller based system where the ADC is available and monitoring the current in real time is required. This pin provides a very low noise voltage signal which is proportional to the output current:

$$V_{LIO} (V) = I_{OUT} \times 12.5 (V).$$

For example, when the output signal equals to 2.5V, the output current is 200mA.

The output impedance of this pin is 10Ω and it can be used to drive an ADC directly.

It can also be measured by a multimeter during debugging process.

Figure 14 below shows the relations among v_{LIS} , v_{LIMS} and i_{OUT}

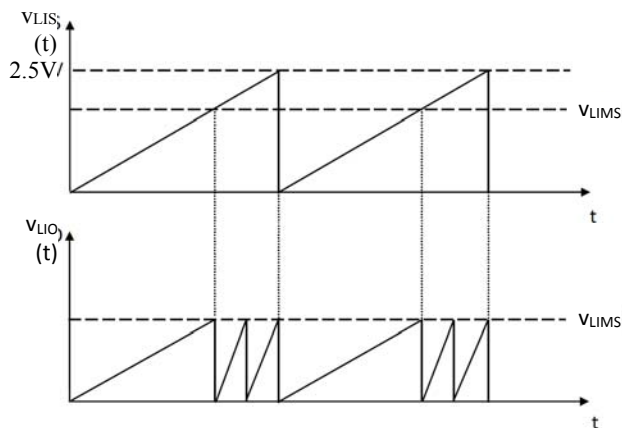

Figure 14. v_{LIS} & v_{LIO}

When $v_{LIS} \leq v_{LIMS}$, i_{OUT} changes with v_{LIS} linearly; when $v_{LIS} > v_{LIMS}$, i_{OUT} oscillates between 0 and v_{LIMS} .

Monitoring the Controller Internal Temperature

The controller internal temperature can be monitored by measuring the TMPO pin voltage. The relationship between the LMPO voltage and the temperature is:

$$T = -1525.04 + 10^3 \sqrt{2.4182 + \frac{1.8015 - TMPO}{3.479}} (^\circ C) \quad (1)$$

where TMPO is the voltage on the TMPO pin.

This formula can be approximated by a linear equation:

$$T = 192.7 - 90.31 \times TMPO (^\circ C) \quad (2)$$

Within the most commonly used temperature range of between 0°C to 100°C, the maximum error occurs at about 1.5V, at which the temperature error between the calculated data by using the formula (1) and the approximated data obtained by using the linear equation (2) is about 0.4°C, with the linear data being a little lower. The curves of the 2 sets of the data are plotted in Figure 17.

Please notice that the TMPO pin has a weak driving capability: the maximum sourcing current is 1μA and the maximum sinking current is 40μA.

The TMPO pin can also be used as an input control pin: when forcing the TMPO voltage to below 0.4V, the laser controller will be shutdown.

Controller Power Consumption

The power consumption of the controller can be calculated by:

$$P_{DRIVER} = I_{OUT} \times (V_{VPS} - V_{LDA}),$$

where I_{OUT} is the output current;

V_{VPS} is the power supply voltage;

V_{LDA} is the voltage across the laser diode.

When the P_{DRIVER} exceeds 1W, a heat sink might be needed. The best way for arranging the heat sinking for the driver is as follows: transferring the heat by sandwiching a piece of thermal conductive pad between the top metal surface of the laser driver and the internal metal surface of the final product as shown in Figure 15.1 and 15.2 below. The recommended thickness of the thermal conductive pad in Figure 15.1 is 1~4mm, and in Figure 15.2 is 0.5mm. ATI also provides a series of thermal conductive pads, click [here](#) for more information.

If prefer not to use the heat sink, this is an option: lowering the controller power consumption by reducing the power supply voltage V_{VPS} . Please make sure:

$$V_{VPS} \geq V_{LDAMAX} + 1V,$$

where V_{LDAMAX} is the maximum possible laser diode voltage.

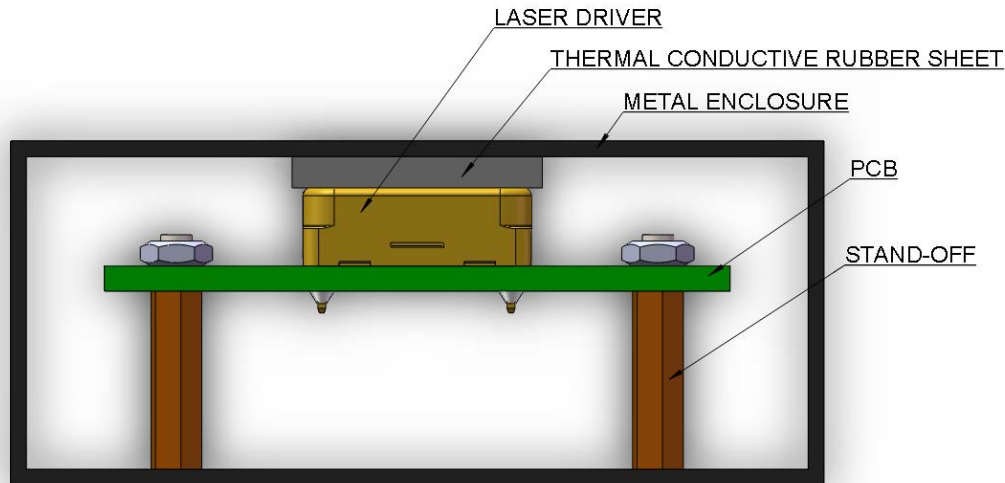

Figure 15.1 Transferring Heat with Metal Enclosure

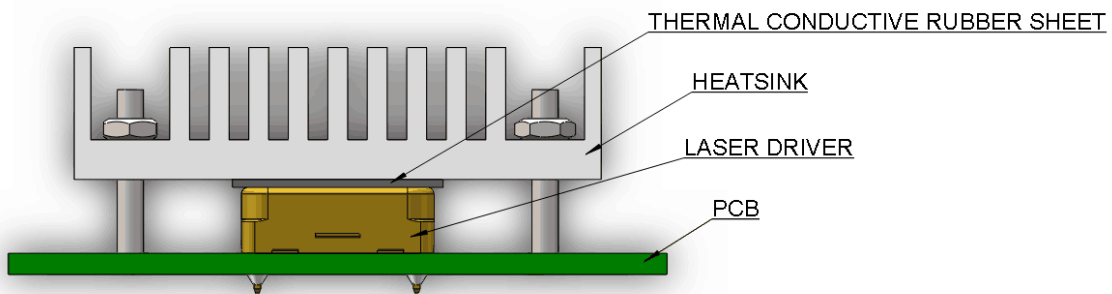

Figure 15.2 Transferring Heat with Heat Sink

First Time Power Up

Laser is a high value and vulnerable device. Faults in connections and damages done to the controller during soldering process may damage the laser permanently.

To protect the laser, it is highly recommend to use 1 to 2 regular diodes of >200mA to form a “dummy laser” and insert it in the place of the real laser diode, when powering up the controller for the first time. Use an oscilloscope to monitor the LDA voltage at times of power-up and power-down, make

sure that there is not over-shoot in voltage. At the same time, use an ammeter in series with the dummy laser, to make sure that the output current is correct.

After thorough checking free of faults, disconnect the dummy laser and connect the real laser in place.

The controller output voltage range for the laser is between 0.4V to $V_{VPS} - 1V$ when powered by a 5V power supply.

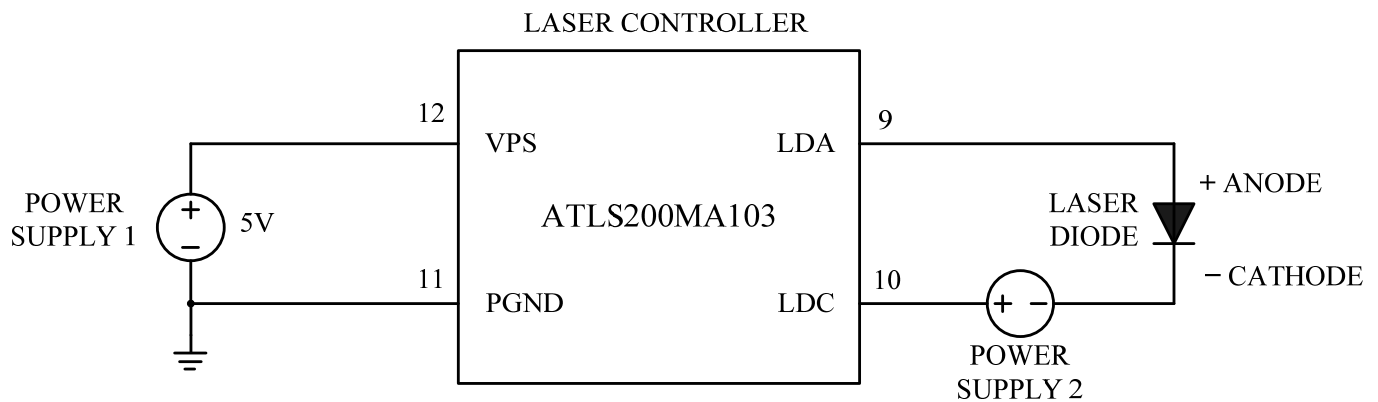

Figure 16. Driving High Voltage Laser Diodes

Driving High Voltage Laser Diodes

Some laser diodes have high forward voltage, such as 7V, while the laser driver ATLS200MA103D has a maximum output voltage of 4V. This section tells a way to drive such laser diodes by using this laser driver.

The schematic is shown in Figure 16, where Power Supply 1 is the power supply for the laser driver, Power Supply 2 is for increasing the laser driver's maximum output voltage.

Please notice that the power on sequence has to be in this way: turn on Power Supply 1, turn on Power Supply 2,

then turn on the laser driver by driving SDN (Shutdown) pin to logic high.

The sequence for turning off the laser circuit is: turn off the SDN pin by pulling it down to the logic low, turn off Power Supply 1, then, turn off power supply 2.

To make sure the circuit works ok: turn on the laser, measure LDA voltage, it should be between 1V to 3V, at room temperature, the ideal LDA voltage is around 2V.

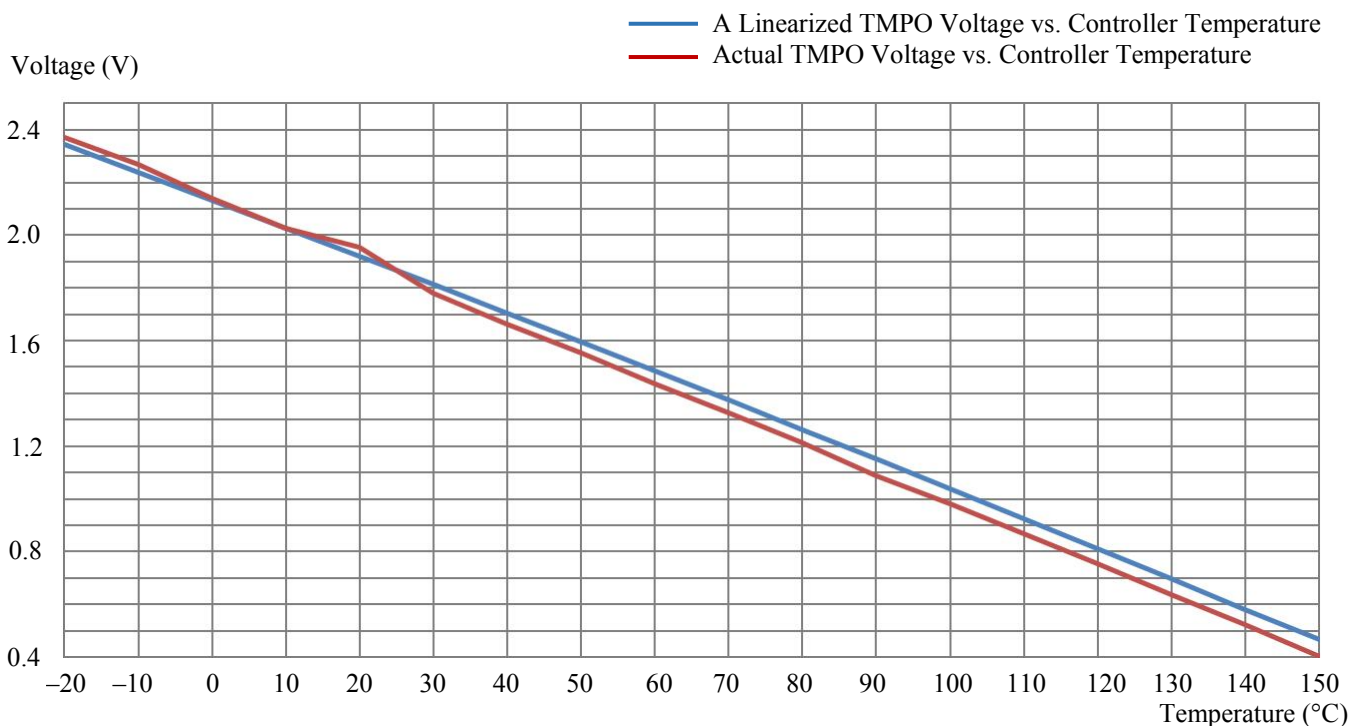

Figure 17. Controller Internal Temperature vs. TMPO Voltage

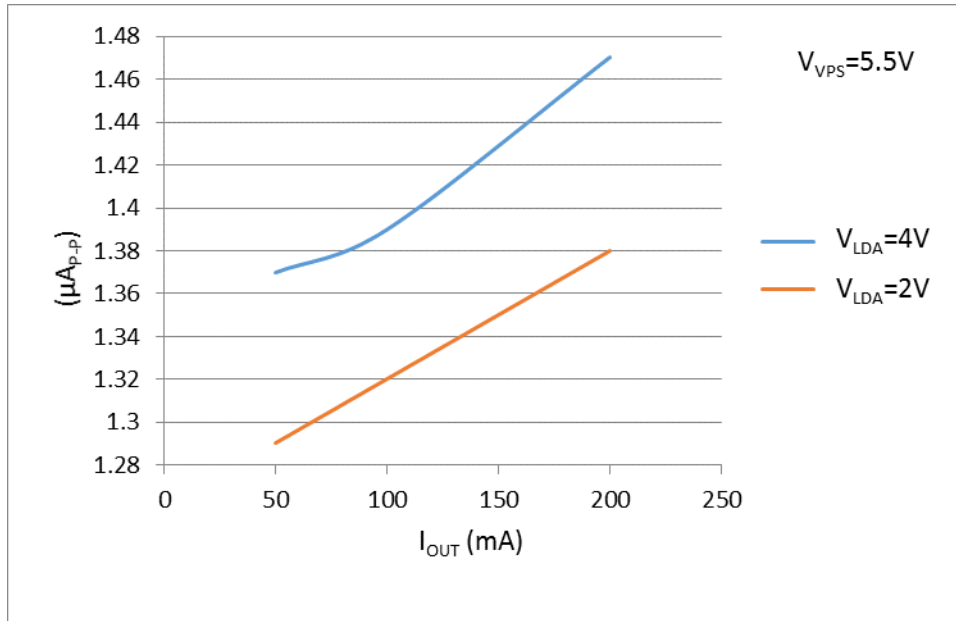

Figure 18. I_{OUT} vs. Output Current Noise@0.1Hz~10Hz

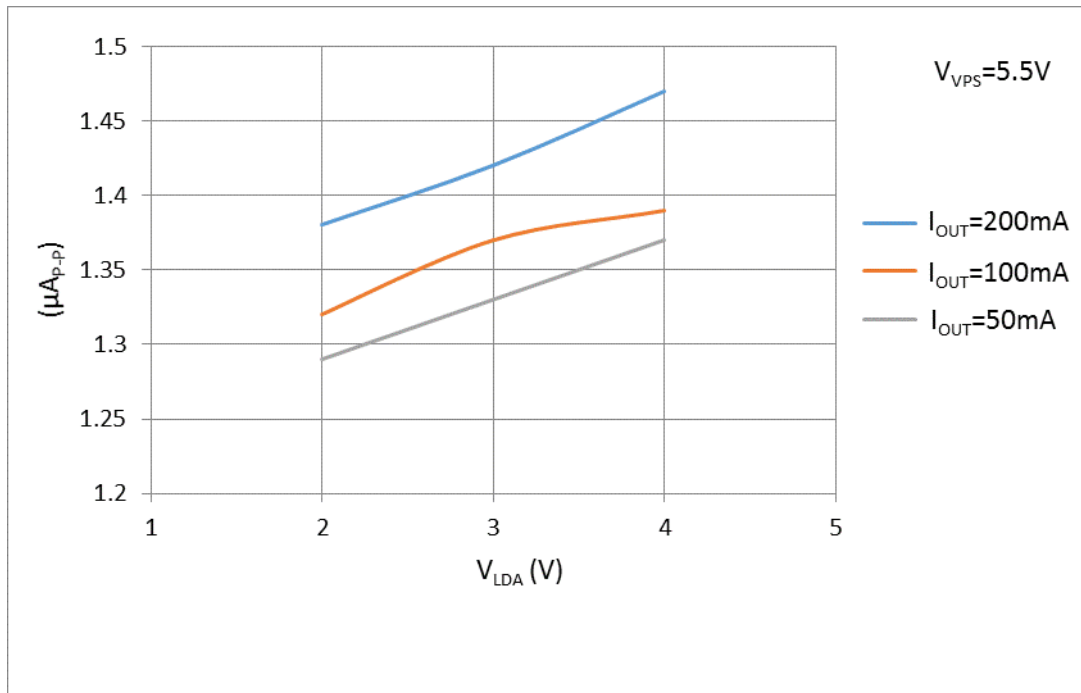

Figure 19. V_{LDA} vs. Output Current Noise@0.1Hz~10Hz

MECHANICAL DIMENSIONS AND MOUNTING

The ATLS200MA103 comes in 2 packages: through hole mount and surface mount. The former is often called DIP (Dual Inline package) or D (short for DIP) package and has a part number: ATLS200MA103D, and the latter is often called SMT (Surface Mount Technology) or SMD (Surface Mount Device) package and has a part number: ATLS200MA103S. See below Figure 20 and 21.

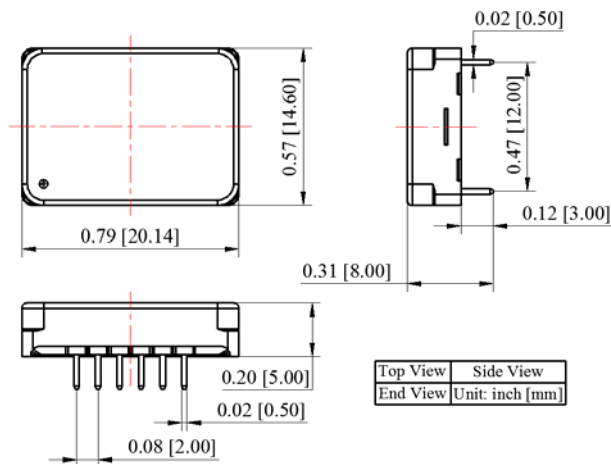

Figure 20. Dimensions of the DIP Package Controller

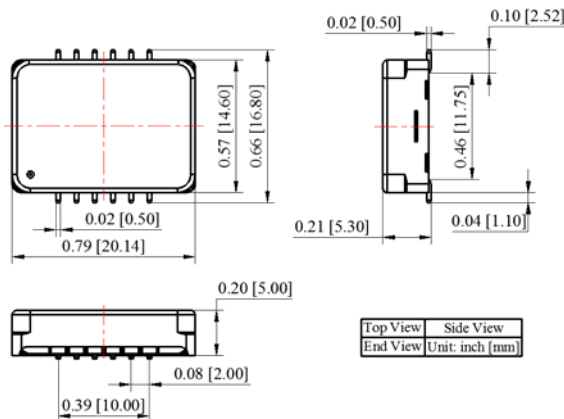

Figure 21. Dimensions of the SMT Package Controller

Figure 22 shows the footprint which is seen from the top side of the PCB, therefore, it is a “see through” view.

Figure 23 shows the view of the bottom side PCB footprint.

“Tent” (i.e. cover the entire via by the solder mask layer) all the vias under the controller, otherwise, the vias can be shorted by the bottom plate of the controller which is internally connected the ground.

Please notice that, in the recommended foot print for the DIP package, the holes for pin 2 to 6, and 8 to 12 have larger holes than needed for the pins. This arrangement will make it easier for removing the controller from the PCB, in case there is a rework needed. The two smaller holes, for pin 1 and 7, will hold the controller in the right position.

It is also recommended to use large copper fills for VPS, PGND, and the LDC pins, and other pins if possible, to decrease the thermal resistance between the module and the supporting PCB, to lower the module temperature.

Please be notice that the SMT version cannot be soldered by reflow oven. It must be soldered manually.

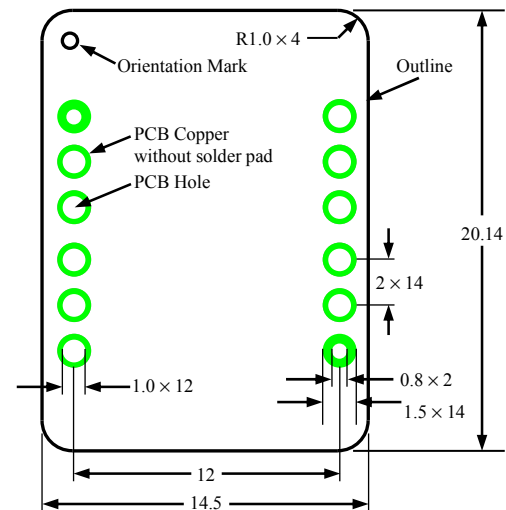

Figure 22. Top Side PCB Foot-print for the DIP Package

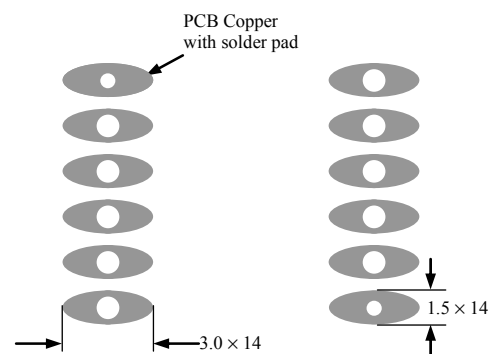

Figure 23. Top View of the Bottom Side PCB Foot-print



WARNING: Both the surface mount and the through hole types of modules can only be soldered manually on the board by a solder iron of < 310°C (590°F), not go through a reflow oven process.

NOTE: The power supply may have overshoot, when happens, it may exceed the maximum allowed input voltage, 6V, of the controller and damage the controller permanently. To avoid this from happening, do the following:

1. Connect the controller solid well with the power supply before turning on the power.
2. Make sure that the power supply has sufficient output current. It is suggested that the power supply can supply 1.2 to 1.5 times the maximum current the controller requires.
3. When using a bench top power supply, set the current limit to >1.5 times higher than the maximum current the controller requires.
4. This laser driver can be evaluated by our evaluation board, [ATLS1A103DEV1.0](#).

ORDERING INFORMATION

Part #	Description
ATLS200MA103D	Controller in DIP package
ATLS200MA103S	Controller in SMT package
ATLS200MA103-PD	Controller with a pull-down resistor of 100k to the ground in SDN pin.

PRICES

Quantity (pcs)	1 – 9	10 – 49	50 – 199	200 – 499	≥500
ATLS200MA103D	\$68.0	\$65.3	\$61.5	\$57.8	\$54.0
ATLS200MA103S					
ATLS200MA103-PD					

RELATED PRODUCTS

Part #	Description	Comments
ATLS100MA103	Linear mode low noise 100mA constant current laser driver	$V_{VPS} = 3.8V \sim 5.5V$; $V_{OUT} = 0V \sim (V_{VPS} - 1V)$; Output noise: $\leq 1.5\mu V_{P-P}$ @0.1Hz to 10Hz;
ATLS250MA103	Linear mode low noise 250mA constant current laser driver	$V_{VPS} = 3.8V \sim 5.5V$; $V_{OUT} = 0V \sim (V_{VPS} - 1V)$; Output noise: $\leq 2.5\mu V_{P-P}$ @0.1Hz to 10Hz;
ATLS500MA103	Linear mode low noise 500mA constant current laser driver	$V_{VPS} = 3.8V \sim 5.5V$; $V_{OUT} = 0V \sim (V_{VPS} - 1V)$; Output noise: $\leq 5\mu V_{P-P}$ @0.1Hz to 10Hz;
ATLS1A103	Linear mode low noise 1A constant current laser driver	$V_{VPS} = 3.8V \sim 5.5V$; $V_{OUT} = 0V \sim (V_{VPS} - 1V)$; Output noise: $\leq 6\mu V_{P-P}$ @0.1Hz to 10Hz;
ATLS1A103DEV1.0	Evaluation board for ATLSXA103D series laser drivers	Evaluate these laser drivers: ATLS100MA103D, ATLS200MA103D, ATLS250MA103D, ATLS500MA103D and ATLS1A103D.



NOTICE

1. ATI warrants performance of its products for one year to the specifications applicable at the time of sale, except for those being damaged by excessive abuse. Products found not meeting the specifications within one year from the date of sale can be exchanged free of charge.
2. ATI reserves the right to make changes to its products or to discontinue any product or service without notice, and advise customers to obtain the latest version of relevant information to verify, before placing orders, that information being relied on is current and complete.
3. All products are sold subject to the terms and conditions of sale supplied at the time of order acknowledgment, including those pertaining to warranty, patent infringement, and limitation of liability. Testing and other quality control techniques are utilized to the extent ATI deems necessary to support this warranty. Specific testing of all parameters of each device is not necessarily performed, except those mandated by government requirements.
4. Customers are responsible for their applications using ATI components. In order to minimize risks associated with the customers' applications, adequate design and operating safeguards must be provided by the customers to minimize inherent or procedural hazards. ATI assumes no liability for applications assistance or customer product design.
5. ATI does not warrant or represent that any license, either express or implied, is granted under any patent right, copyright, mask work right, or other intellectual property right of ATI covering or relating to any combination, machine, or process in which such products or services might be or are used. ATI's publication of information regarding any third party's products or services does not constitute ATI's approval, warranty or endorsement thereof.
6. IP (Intellectual Property) Ownership: ATI retains the ownership of full rights for special technologies and/or techniques embedded in its products, the designs for mechanics, optics, plus all modifications, improvements, and inventions made by ATI for its products and/or projects.