



Figure 1. Physical Photo of ATLS1.5A104

### FEATURES

- Ultra-Low Noise (RMS):  $<0.95\mu\text{A}_{\text{RMS}}@ 0.1\text{Hz} \sim 10\text{Hz}$
- High  $I_{\text{OUT}}$ : 1.5A
- High  $I_{\text{OUT}}$  Absolute Accuracy:  $1500\pm 0.5$  (mA) @  $V_{\text{LIS}}=2.5\text{V}$
- High  $I_{\text{OUT}}$  Stability:  $<\pm 0.5\text{mA}$  @  $T = -30^\circ\text{C} \sim 60^\circ\text{C}$
- Independently programmable  $I_{\text{OUT}}$  and  $I_{\text{OUT}}$  limit
- Loop good indication
- Controller internal temperature monitoring
- Complete Shielding
- Compact Size
- 100 % Lead (Pb)-free and RoHS Compliant
- DIP and SMT Packages Available
- Soft-Start

### APPLICATIONS

Driving laser diodes with ultra-low noise, such as DPSSL, EDFA, SOA, fiber laser, DSB diode lasers, etc.

### DESCRIPTION

The ATLS1.5A104 is an electronic module designed for driving diode lasers with up to 1.5A extra low noise current. The output voltage is 0.5V to 3.5V when powered by a 5.5V power supply. Figure 1 shows the photo of ATLS1.5A104.

The controller has temperature compensation network so

that the output current maintains the same even as the controller temperature rises.

In case the controller temperature exceeds a preset limit,  $120^\circ\text{C}$ , the controller will be shut down by itself to prevent the controller from being damaged by the over heat.

The output current of the ATLS1.5A104 can be set by an input voltage linearly or modulated by an external signal of up to 1.75MHz in bandwidth, resulting in a minimum 200nS rise and fall times at the output current.

A highly stable low noise 2.5V reference voltage is provided internally for setting the output current. This reference can also be used as the voltage reference for external ADCs (Analog to Digital Converters) and/or DACs (Digital to Analog Converters) which are utilized for converting the analog signals, such as LIO which represents the output current, into digital signals, and/or converting the digital signals into analog ones for setting the analog voltages, such as LIS which sets the output current.

The ATLS1.5A104 is packaged in a 6 sided metal enclosure, which blocks EMIs (Electro-Magnetic Interferences) to prevent the controller and other electronics from interfering each other.

This laser driver can be evaluated by our evaluation board, [ATLS1A103DEV1.0](#).

There are 2 packaging versions available: DIP through hole package and surface mount type.

**Warning:** Both the surface mount and the through hole types of modules can only be soldered manually on the board by a solder iron of  $< 310^\circ\text{C}$  ( $590^\circ\text{F}$ ), not go through a reflow oven process.

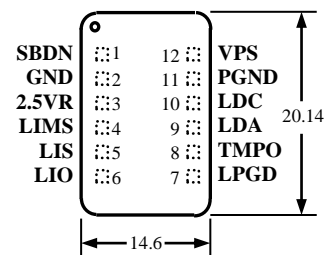

Figure 2. Pin Names and Locations

Figure 2 is the actual size top view of the ATLS1.5A104, which shows the pin names and locations. Its thickness is 5mm.

Table 1. Pin Function Descriptions

Pin #	Pin Name	Pin Type	Description
1	SBDN	Analog/Digital Input	Standby and Shutdown Control. This pin has 3 states: between $0\text{V} \sim 0.4\text{V}$ , it shuts down the entire laser driver; between $1.2\text{V} \sim 2.4\text{V}$ , it sets the laser driver to standby mode; between $2.7\text{V} \sim 5.5\text{V}$ , it sets the laser driver to operation mode. The input current on this pin is $<2\mu\text{A}$ . See Figure 3.



2	GND	Signal ground	Signal ground pin. Connect ADC and DAC grounds to here.
3	2.5VR	Analog output	2.5V reference voltage. It is used by the external DACs as the reference voltage. It can source 3mA max, with 3.6 $\mu$ A <sub>p-p</sub> noise @ 0.1 to 10 Hz and 25ppm/ $^{\circ}$ C stability max.
4	LIMS	Analog input	Laser current limit set. 0V to 2.5V sets the laser current limit from 0 to 1.5A linearly.
5	LIS	Analog input	Laser current set. 0V to 2.5V sets the laser current from 0 to 1.5A linearly.
6	LIO	Analog output	Laser current output indication. 0V to 2.5V indicates the laser current from 0 to 1.5A linearly.
7	LPGD	Digital output	Loop good indication. When the controller is working properly, the actual output current equals the set-point current, this pin goes up; otherwise, it goes down.
8	TMPO	Analog output	The driver internal temperature indication output.
9	LDA	Power output	Laser diode anode. Connect it to the anode of the laser diode. This pin is used to drive the type of diode laser of which the cathode is connected to its case and the case is connected to the ground. See below Figure 4, and Figure 5.1 ~ Figure 5.3.
10	LDC	Power output	Laser diode cathode. Connect it directly to the laser's cathode. See below Figure 4, and Figure 5.1 ~ Figure 5.3.
11	PGND	Power ground	Power ground pin. Connect it directly to power supply return rail.
12	VPS	Power input	Power supply. The driver works from 3.1V to 5.5V.

**SPECIFICATIONS**

 Table 2. Characteristics ( $T_{\text{Ambient}} = 25^{\circ}\text{C}$ )

Parameter	Value	Unit/Note
Maximum Output Current	1.5	A
Peak-to-Peak Noise @ 0.1Hz ~ 10Hz, $V_{\text{VPS}}=5\text{V}$ , $R_{\text{S}}=1\Omega$ , $V_{\text{OUT}}=3\text{V}$ , $I_{\text{OUT}}=1.5\text{A}$	6.27	$\mu\text{A}_{\text{P-P}}$
Current Noise Density @ 0.1Hz ~ 10Hz, $V_{\text{VPS}}=5\text{V}$ , $R_{\text{S}}=1\Omega$ , $V_{\text{OUT}}=3\text{V}$ , $I_{\text{OUT}}=1.5\text{A}$	0.95	$\mu\text{A}_{\text{RMS}}$
Current Set Voltage Range ( $V_{\text{LIS}}$ )	0 ~ 2.5	V
Current Limit Set Voltage Range ( $V_{\text{LIMS}}$ )	0 ~ 2.75	V
Rise and Fall Times of large signal	200	nS
Rise and Fall Times of small signal	192	nS
Bandwidth of large signal (0.2V ~ 2.2V square wave)	1.75	MHz
Bandwidth of small signal (1V DC plus 200mV AC square wave)	1.82	MHz
Minimum Drop Out Voltage	0.9 + $0.3 \times I_{\text{OUT}}$	V
Power Supply Voltage Range	3.1 ~ 5.5	V
Operating Case Temperature	-40 ~ 85	$^{\circ}\text{C}$
Storage temperature	-55 ~ 150	$^{\circ}\text{C}$
High $I_{\text{OUT}}$ Absolute Accuracy ( $T = -30^{\circ}\text{C} \sim 60^{\circ}\text{C}$ )	$< \pm 0.5$	mA
High $I_{\text{OUT}}$ Stability (the load can be made of 1 to 5 diodes)	$< \pm 0.5$	mA

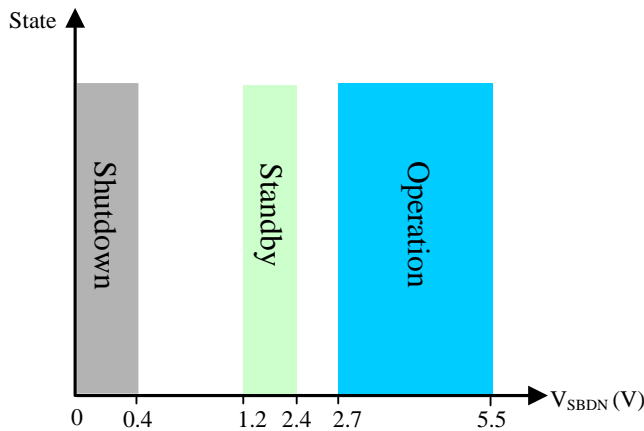

Figure 3. Input Control

**OPERATION PRINCIPLE**

The block diagram of the controller is shown in Figure 4.

The shutdown control circuit is activated under one of these 3 circumstances: external shut down, output current exceeds the current limit, and the internal temperature exceeds  $120^{\circ}\text{C}$ .

When the controller is shut down by the external shutdown signal, it will restart upon detecting the releasing of the shutdown signal.

When the controller is shut down by the over temperature, it will wait till the temperature goes below the temperature limit,  $120^{\circ}\text{C}$ . Usually it takes a few or tens of seconds for the controller to cool down before it restarts itself, depending on the thermal mass of the controller and its surrounding mechanical parts attached thermally, such as the PCB and its traces, the heat-sinks if any, etc.

When controller is shut down, the voltage reference is also shut down.

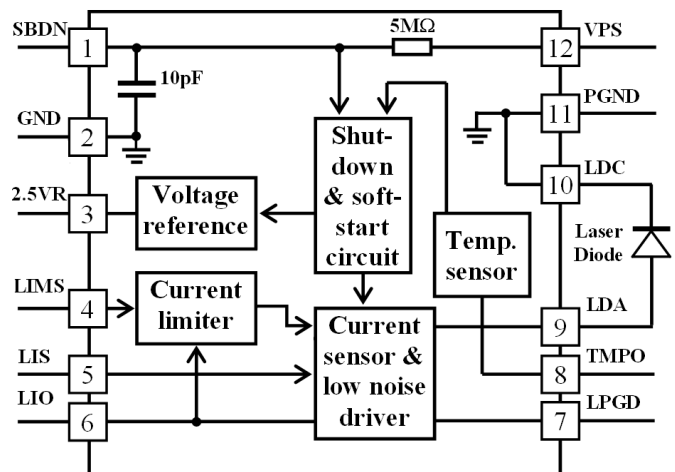

Figure 4. Block Diagram

**APPLICATIONS**

Figure 5.1 shows the SBDN external circuit; If SBDN logic is high in default, at that time, the controller has a 1.5M pull-up resistor internally, with the part number ATLS1.5A104. Figure 5.2 shows a typical application circuit. If SBDN logic is low in default, at that time, the controller has a 1.5M pull-down resistor internally, with the part number ATLS1.5A104-PD. Figure 5.3 shows the SBDN external circuit. W1 and W2 set the output current limit and output current respectively. Resistor R1 and

capacitor C1 form a low pass filter, to lower the noise from the voltage reference.

Laser diode is connected between LDA and LDC. It is worth mentioning that the power supply return terminal should be connected to the pin 11 PGND and the cathode of the laser diode should be connected to the pin 10 LDC. These 2 nodes should not be connected together externally and they are connected together internally already by the controller.

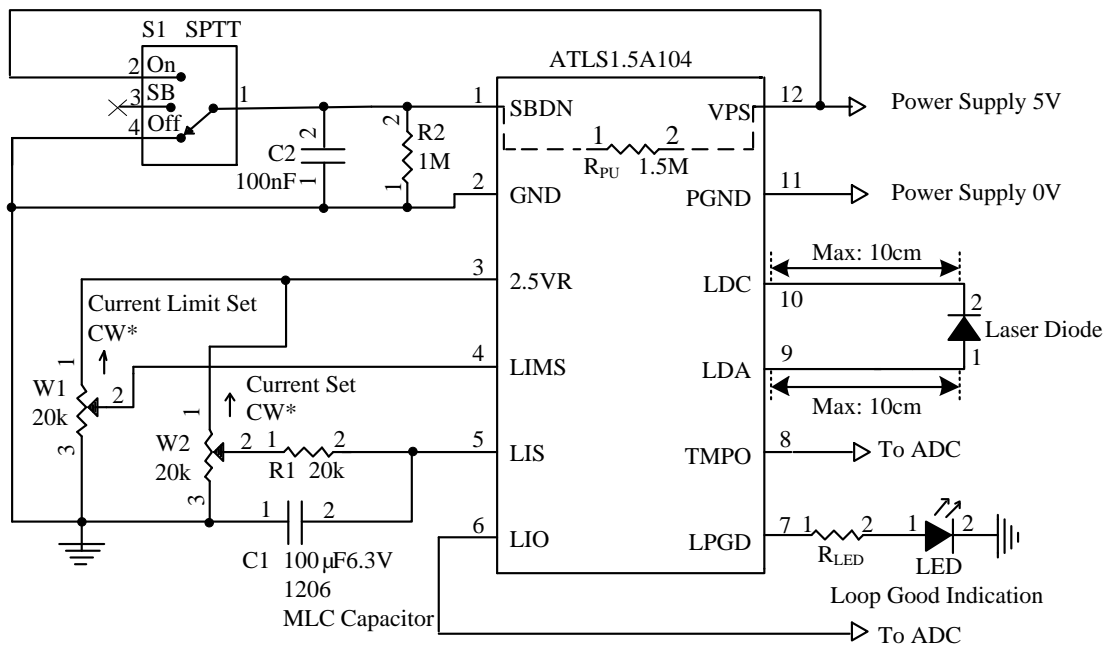

Figure 5.1. Typical Stand-alone CW Operation Schematic for ATLS1.5A104

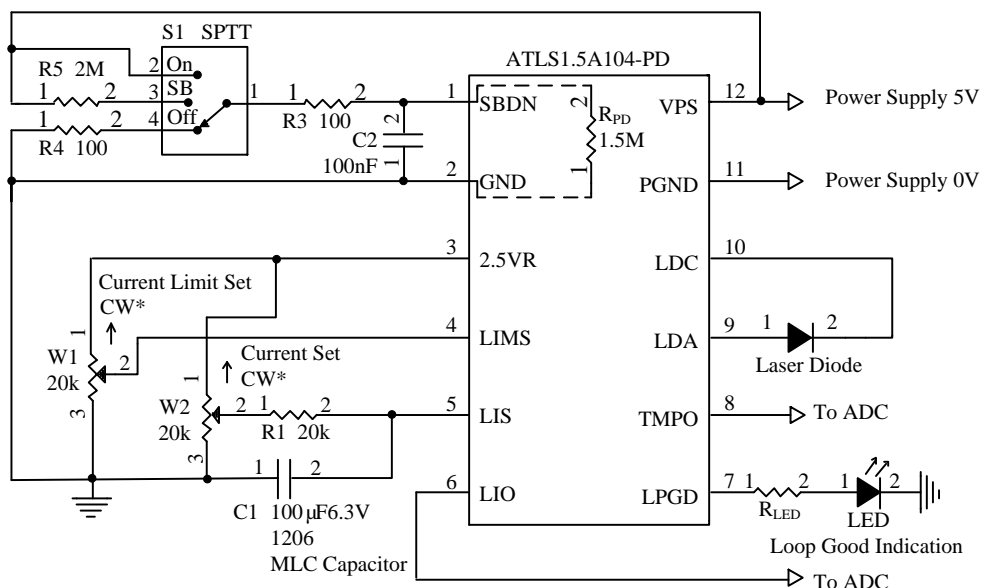

Figure 5.2. Typical Stand-alone CW Operation Schematic for ATLS1.5A104-PD

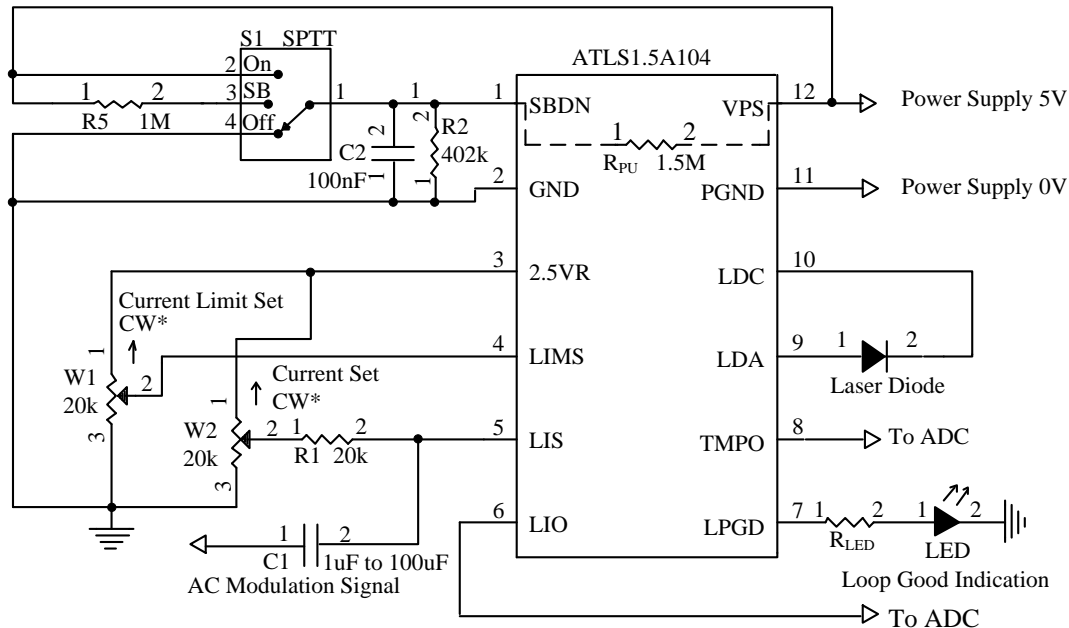

Figure 5.3. Typical AC Modulation with DC bias Schematic for ATLS1.5A104

### Turning the Controller On & Off and Standby Mode

The controller can be turned on and off by setting the SBDN pin high and low respectively. It is recommended to turn the controller on by this sequence:

**To turn on:** turn on the power by providing the power supply voltage to the controller, turn on the controller by releasing the SBDN pin.

**To turn off:** turn off the controller by lowering the voltage of SBDN pin, turn off the power by stopping the voltage supply on the VPS pin.

**Standby:** add 2.4V to SBDN. When controller is in standby mode, the voltage reference is still working.

### SBDN controlled by microcontroller

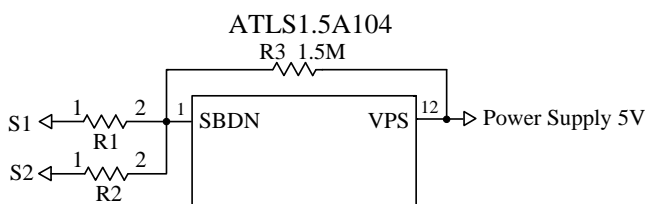

Figure 6. SBDN controlled by microcontroller

Table 3.

VDD	R1	R2
5V	54k	50k
3.3V	18.7k	50k

2.5V	2k	50k
------	----	-----

Table 4.

S2	S1	State
0	0	Shutdown
0	1	Standby
1	1	On

In Figure 5.1, S1 is the shutdown switch. The internal equivalent input circuit of SBDN pin is a pull-up resistor of 1M being connected to VPS. The switch S1 can also be an electronic switch, such as an I/O pin of a microcontroller, with an either open drain or push/pull output. Figure 6 shows SBDN controlled by microcontroller. Table 3 shows the reference value of R1, R2 with different microcontroller power supplies. Table 4 shows the logic level of S1, S2 in different states. If not using a switch (S1) to control the laser, leave the SBDN pin unconnected. The LED, indicating when the control loop works properly, that is: the output current equals to the input set value. The  $R_{LED}$  can be calculated by this formula:

$$R_{LED} = (V_{VPS} - V_{LED}) / I_{LED}$$

When choosing not to use an LED for indicating the working status, leave the LPGD pin unconnected.

The LPGD pin can also be connected to a digital input pin of a micro-controller, when software/firmware is utilized in the system.

### Setting the Output Current

The output current limit is set by adjusting W1, which sets input voltages of LIMS, pin 4. The output current will be:  
 $I_{LIMS} (A) = V_{LIMS} (V) \times 1.5 (A) / 2.5 (V)$

LIMS should never be left float. Otherwise, the output current limit may be set to too high a value that the laser might be damaged.

The output current is set by adjusting W2, which sets input voltages of LIS, pin 5. The output current will be:

$$I_{LIS} (A) = V_{LIS} (V) \times 1.5 (A) / 2.5 (V).$$

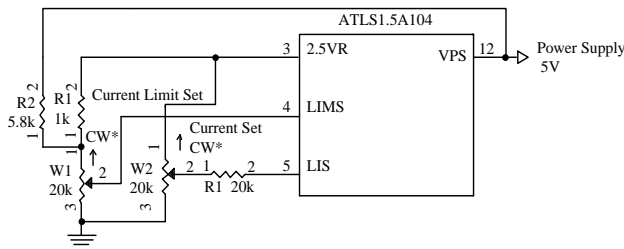

Figure 7.  $V_{LIMS}$  setting larger than  $V_{LIS}$

Usually, the voltage of LIS should be lower than LIMS, so the output current is determined by LIS. If the output current is set to 1.5A, the voltage of LIMS should be larger than 2.5V. Figure 7 shows when the output current is set to 1.5A, 0V to 2.75V sets the laser current limit from 0 to 1.65A linearly.

When no modulation is needed, it is suggested to use an RC low-pass-filter, the R1 and C1 in Figure 5.1 ~ Figure 5.3, to lower the AC noise from the voltage reference source. The time constant of this filter can be between a few to 10's of

seconds. The bigger the time cost, the lower the output noise, but the longer time will be needed to wait the output current to go up.

Both of LIMS and LIS, only LIS, can be configured by using a DAC, to replace the W1 and W2 in Figure 5.1 ~ Figure 5.3. Make sure that the DAC has output low noise, or, if no modulation is needed, an RC low pass filtered by be inserted between the DAC and the LIS pin, similar as shown in Figure 5.1 ~ Figure 5.3.

The LIS allows modulating the output current by a signal of up to 1.75MHz in bandwidth. That is, when using a sine wave signal to modulate the LIS pin, the output current response curve will be attenuated by 3dB, or 0.707 times the full response magnitude in current. When using an ideal square-wave to modulate the output current at the LIS pin, the rise and fall time of the output current will be about 192ns (small signal).

When the modulation signal is a square-wave and low output noise is required, the low-pass-filter can still be used for lowering the output noise. Figure 8 shows such a circuit. VL is the valley current during digital modulation on the LIS pin, which can be set at any value between zero to the maximum operation current. However, if needing high speed low distortion on/off modulation, this value needs to be set near but below the threshold current of the laser diode, in this way, the laser is turned off optically when switched to the VL value, but kept on electrically, so that there is no time delay inserted for starting up the laser if VL were set to zero. The VL value is determined by R5.

It is recommended not to set the LIS pin to 0V, but keep it >0.05V at all the time. The reason is that the laser diode usually has a junction voltage of 2.5V, when setting the LIS pin voltage to 0V, the output voltage will warble between 0V and 2.5V, cause some oscillation slightly.

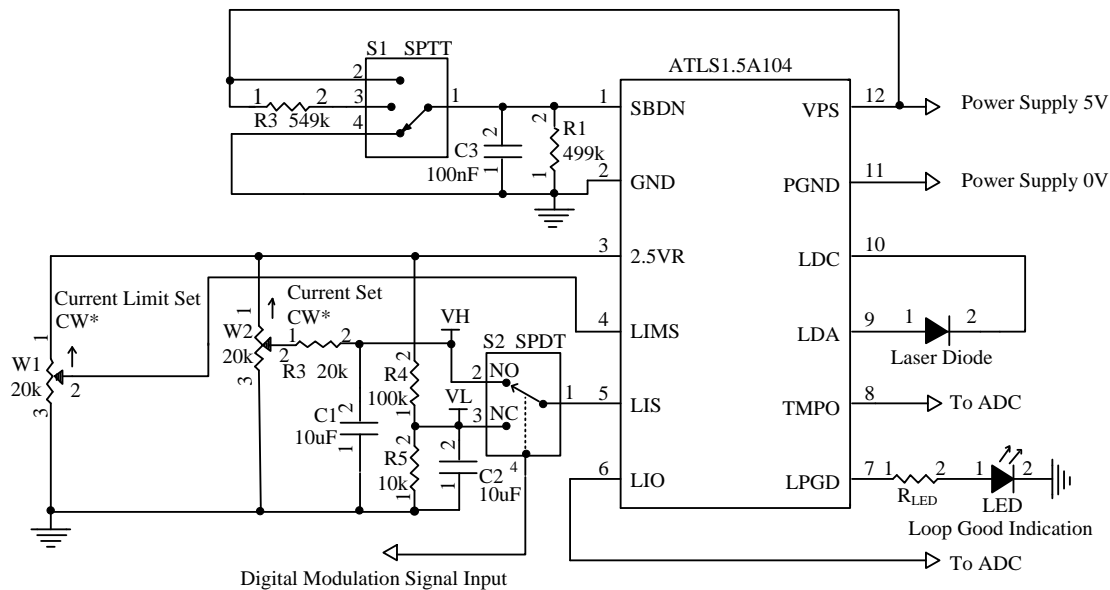

Figure 8. Low Noise Digital Modulation Circuit

### Monitoring the Output Current

The output current of the controller can be monitored by measuring the voltage on the LIO pin. This feature is very useful for micro-controller based system where the ADC is available and monitoring the current in real time is required. This pin provides a very low noise voltage signal which is proportional to the output current:

$$V_{LIO} (V) = I_{OUT} (A) \times 2.5 (V) / 1.5A.$$

For example, when the output signal equals to 2.5V, the output current is 1.5A.

The output impedance of this pin is  $10\Omega$  and it can be used to drive an ADC directly.

It can also be measured by a multimeter during debugging process.

Figure 9 below shows the relations among  $V_{LIS}$ ,  $V_{LIMS}$  and  $i_{OUT}$

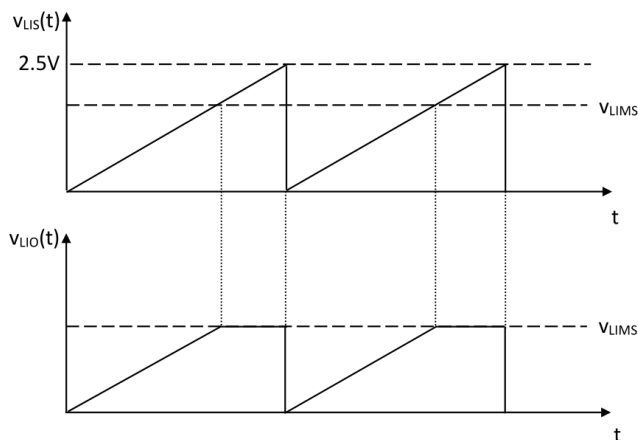

Figure 9. LIO is Controlled by LIS and Clamped by LIMS

When the output current set by LIS is less than the current limit set by LIMS, the actual output current  $I_{OUT}$  changes with LIS linearly; when output current set by LIS exceeds the current limit set by LIMS,  $I_{OUT}$  will be clamped to the value set by the LIMS, see Figure 9.

### Monitoring the Controller Internal Temperature

The controller internal temperature can be monitored by measuring the TMPO pin voltage. The relationship between the TMPO voltage and the temperature is:

$$T = -1525.04 + 10^3 \sqrt{2.4182 + \frac{1.8015 - V_{TMPO}}{3.479}} (^\circ C) \quad (1)$$

where  $V_{TMPO}$  is the voltage on the TMPO pin.

This formula can be approximated by a linear equation:

$$T = 192.7 - 90.31 \times V_{TMPO} (^\circ C) \quad (2)$$

Within the most commonly used temperature range of between  $0^\circ C$  to  $100^\circ C$ , the maximum error occurs at about  $1.5V$ , at which the temperature error between the calculated data by using the formula (1) and the approximated data obtained by using the linear equation (2) is about  $0.4^\circ C$ , with the linear data being a little lower. The curves of the 2 sets of the data are plotted in Figure 20.

Please notice that the TMPO pin has a weak driving capability: the maximum sourcing current is  $1\mu A$  and the maximum sinking current is  $40\mu A$ .

The TMPO pin can also be used as an input control pin: when forcing the TMPO voltage to below  $0.4V$ , the laser controller will be shut down.

### Controller Power Consumption

When the maximum power consumed by the controller is maintained to <1W, it does not require a heat sink to operate. The power dissipated by the controller can be calculated by this formula:

$$I_{VPS} = I_Q + I_{OUT}$$

$$P_{IN} = V_{VPS} \times I_{VPS}$$

$$P_{OUT} = V_{OUT} \times I_{OUT}$$

$$P_{DRIVER} = P_{IN} - P_{OUT}$$

$$= V_{VPS} \times I_Q + (V_{VPS} - V_{OUT}) \times I_{OUT}$$

Where  $I_{VPS}$  is the input current at the VPS node,  $V_{VPS}$  is the power supply voltage,  $I_{GND}$  is the ground pin current,  $V_{OUT}$  is the output voltage at the load,  $I_{OUT}$  is the output current going through the load.

Figure 10 shows the current distributions of the controller.

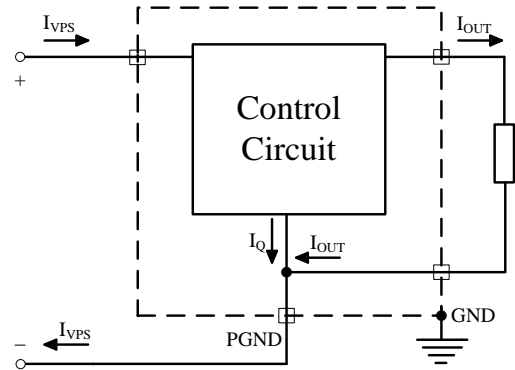

Figure 10. The Current Distributions in the Controller

When the  $P_{DRIVER}$  exceeds 1W, a heat sink might be needed. Under this situation, if prefer not to use the heat sink, this is an option: lowering the controller power consumption by reducing the power supply voltage  $V_{VPS}$ . Please make sure:

$$V_{VPS} \geq V_{OUTMAX} + 1V,$$

where  $V_{OUTMAX}$  is the maximum possible laser diode voltage.

monitor the LDA voltage at times of power-up and power-down, make sure that there is not over-shoot in voltage. At the same time, use an ammeter in serious with the dummy laser, to make sure that the output current is correct.

After thorough checking free of faults, disconnect the dummy laser and connect the real laser in place.

The controller output voltage range for the laser is between 0.5V to 4V when powered by a 5V power supply.

### First Time Power Up

Laser is a high value and vulnerable device. Faults in connections and damages done to the controller during soldering process may damage the laser permanently.

To protect the laser, it is highly recommend to use 3 to 4 regular diodes of >200mA to form a “dummy laser” and insert it in the place of the real laser diode, when powering up the controller for the first time. Use an oscilloscope to

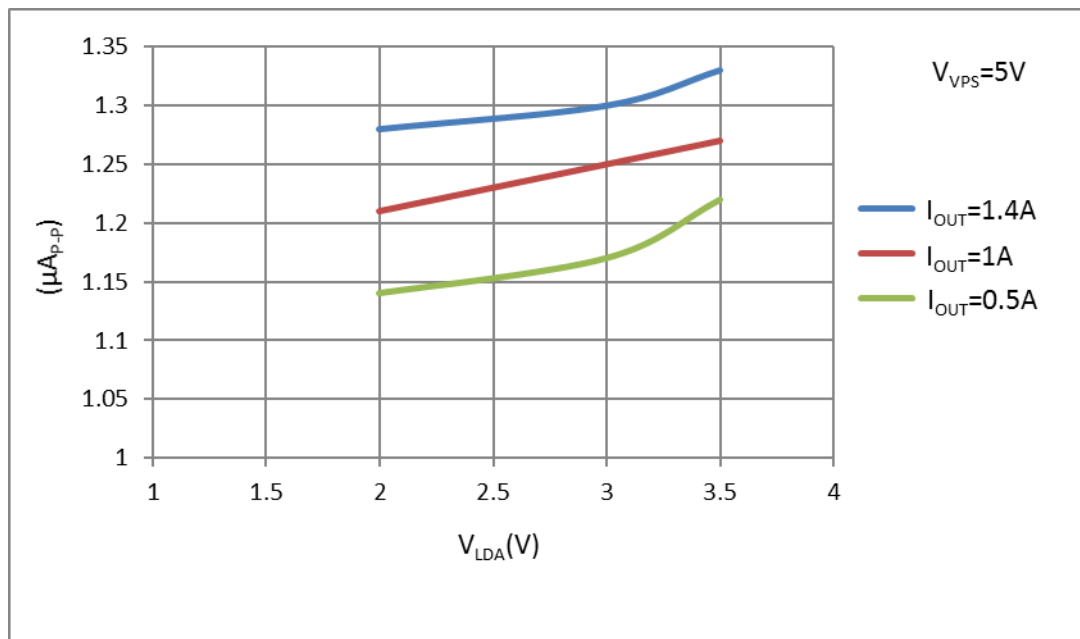

Figure 11.1.  $V_{LDA}$  vs. Output Current Noise@0.1Hz~10Hz



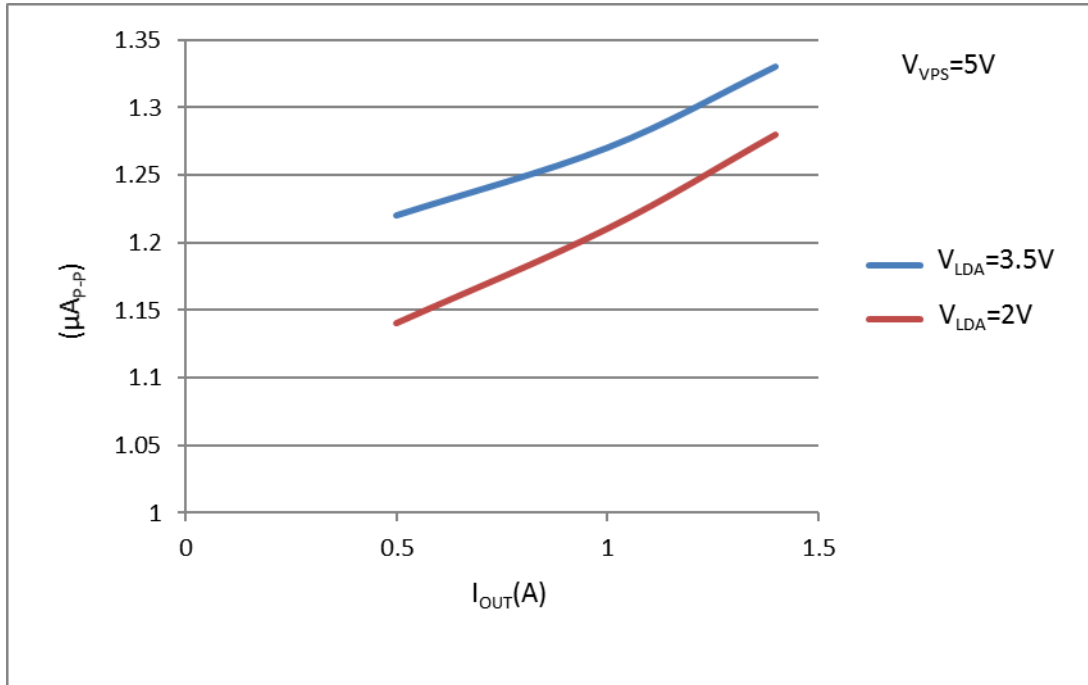

Figure 11.2.  $I_{OUT}$  vs. Output Current Noise@0.1Hz~10Hz

**The Rise and Fall Time of Large and Small Signal**

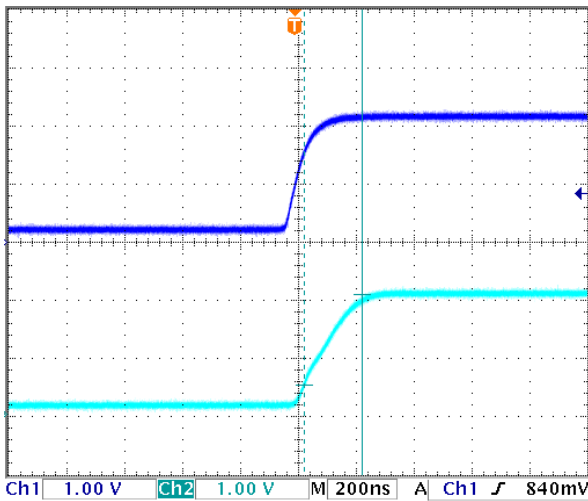

Figure 12.1. Large Signal Rise Time 200ns

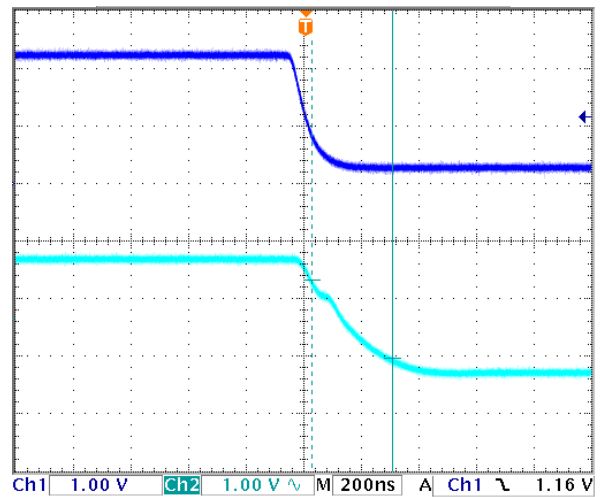

Figure 12.2. Large Signal Fall Time 280ns

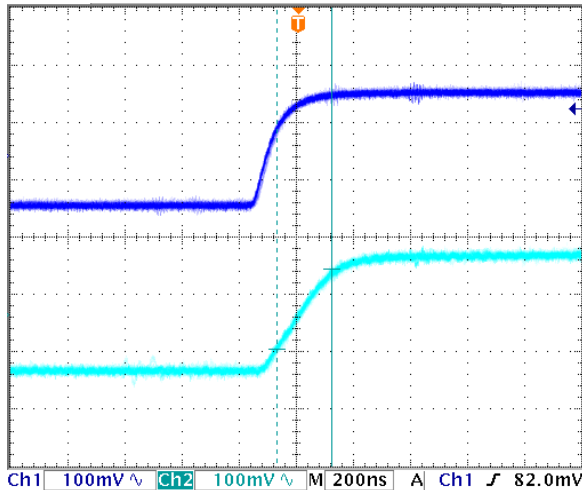

Figure 12.3. Small Signal Rise Time 192ns

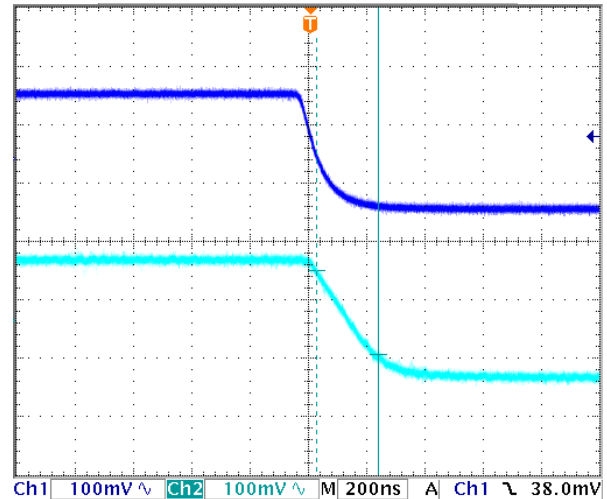

Figure 12.4. Small Signal Fall Time 212ns

**Bandwidth Measurement**

There are two methods to measure the bandwidth: large signal modulation and small signal modulation. The measuring methods are as below.

**Small Signal Modulation Definition**

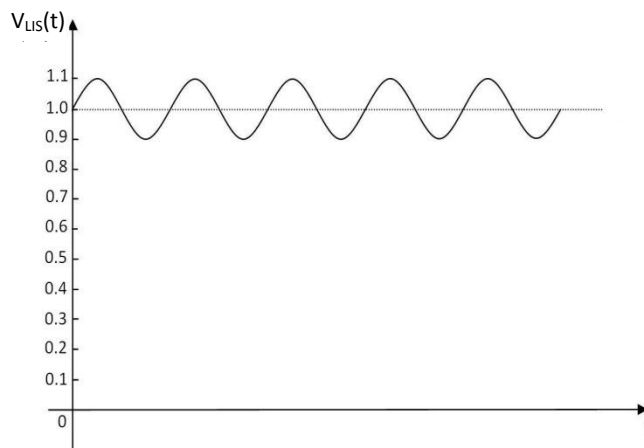

Figure 13. Small Signal Modulation

As shown in Figure 13, add a sine signal of 1V DC +0.2V<sub>P-P</sub> AC (the frequency increases gradually) to LIS and then measure the AC voltage on LIS and LIO. Figure 5.3.shows external circuit.

Figure 14. Large Signal Modulation

As shown in Figure 14, when a square wave of 0.2V~2.2V,  $f = 100\text{Hz}$ , is applied to LIS, measure the waveform of LIO. The rise and fall time should be about 200ns, the equivalent bandwidth can be calculated by:  $f = 0.35/t_{\text{RISE}} = 0.35/0.200\mu\text{s} = 1.75\text{MHz}$ .

The above two methods can be applied to test if the bandwidth is 1.75MHz.

In practice, the small signal bandwidth is usually much higher than the large signal bandwidth.

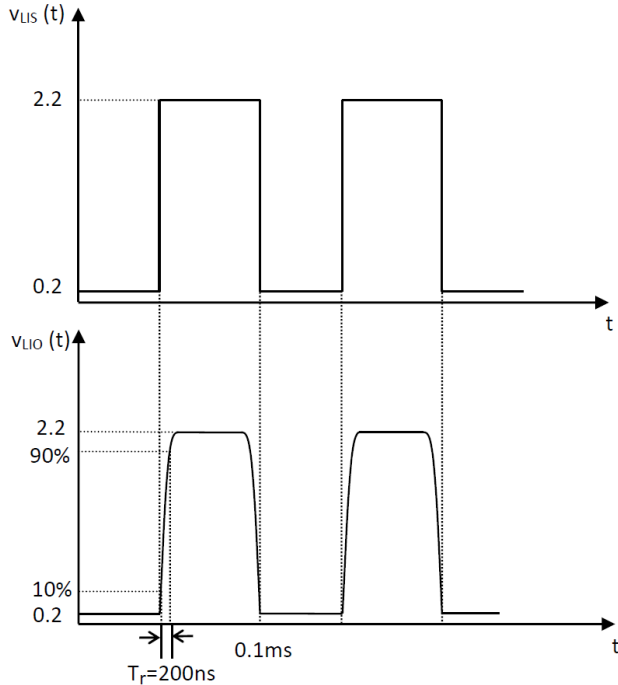
**Large Signal Modulation Definition**

**Turn-On/Turn-Off Timing**

ATLS1.5A104 has soft-start function. As shown in Figure 15 to Figure 18, when shutdown is from Off to On, the rise time of LDA and LIO is about 2.4ms, and 2.5VR has about 7ms delay, with the rise time of about 3ms; When shutdown is from On to Off, the fall time of LDA and LIO is about 0.2ms, and 2.5VR has about 4ms delay with the fall time of about 16ms.

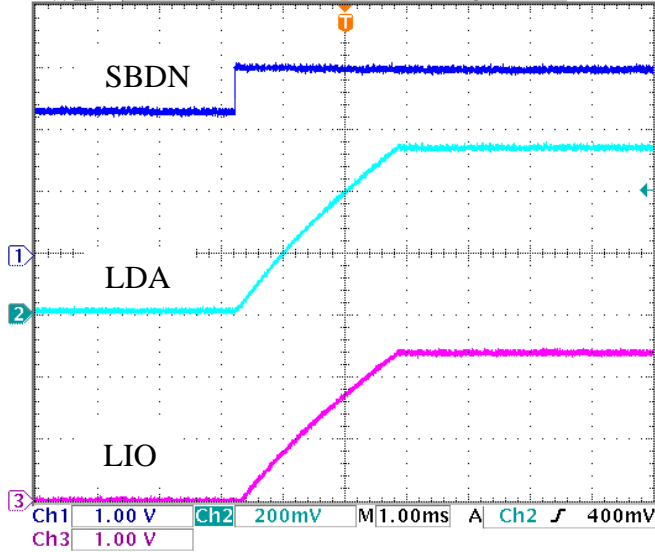

Figure 15. The rise time of SBDN, LDA and LIO

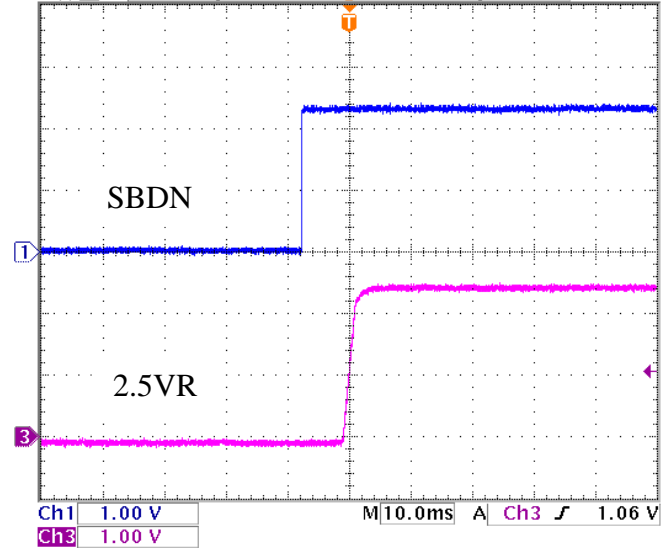

Figure 17. The rise time of SBDN vs. 2.5VR

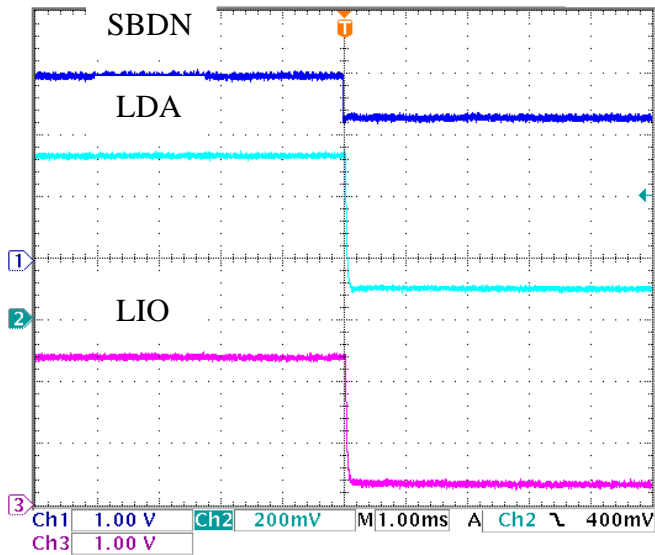

Figure 16. The fall time of SBDN, LDA and LIO

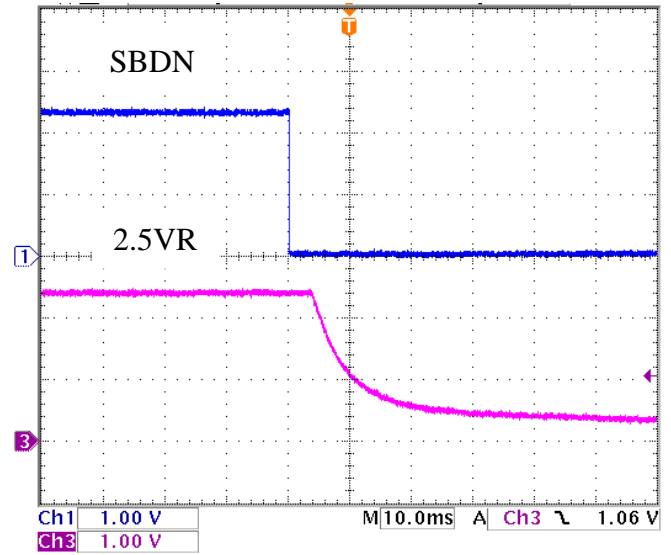

Figure 18. The fall time of SBDN vs. 2.5VR

**Controller Power Consumption**

The power consumption of the controller can be calculated by:

$$P_{DRIVER} = I_{OUT} \times (V_{VPS} - V_{LDA}),$$

where  $I_{OUT}$  is the output current;

$V_{VPS}$  is the power supply voltage;

$V_{LDA}$  is the voltage across the laser diode.

When the  $P_{DRIVER}$  exceeds 1W, a heat sink might be needed. The best way for arranging the heat sinking for the driver is as follows: transferring the heat by sandwiching a piece of thermal conductive pad between the top metal surface of

the laser driver and the internal metal surface of the final product as shown in Figure 19.1 and 19.2 below. The recommended thickness of the thermal conductive pad in Figure 19.1 is 1~4mm, and in Figure 19.2 is 0.5mm. ATI also provides a series of thermal conductive pads, click [here](#) for more information.

If prefer not to use the heat sink, this is an option: lowering the controller power consumption by reducing the power supply voltage  $V_{VPS}$ . Please make sure:

$$V_{VPS} \geq V_{LDAMAX} + 1V,$$

where  $V_{LDAMAX}$  is the maximum possible laser diode voltage.

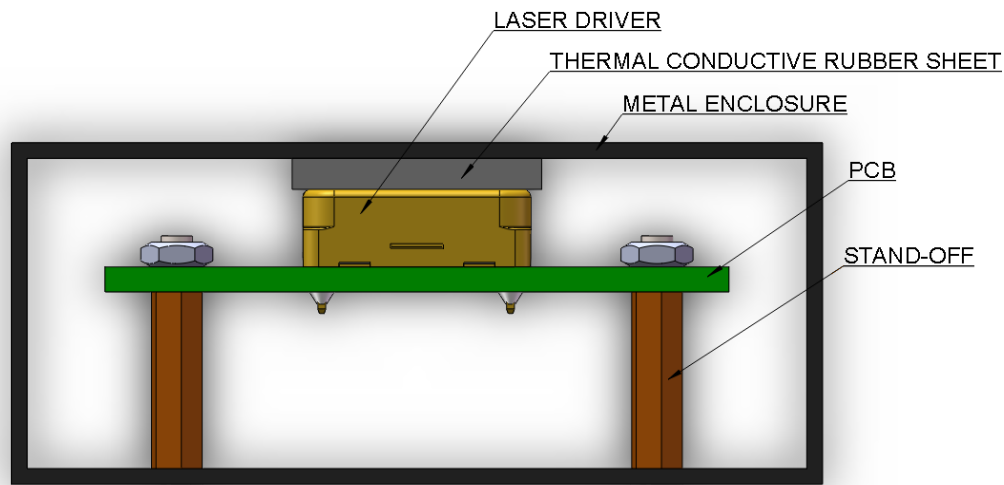

Figure 19.1 Transferring Heat with Metal Enclosure

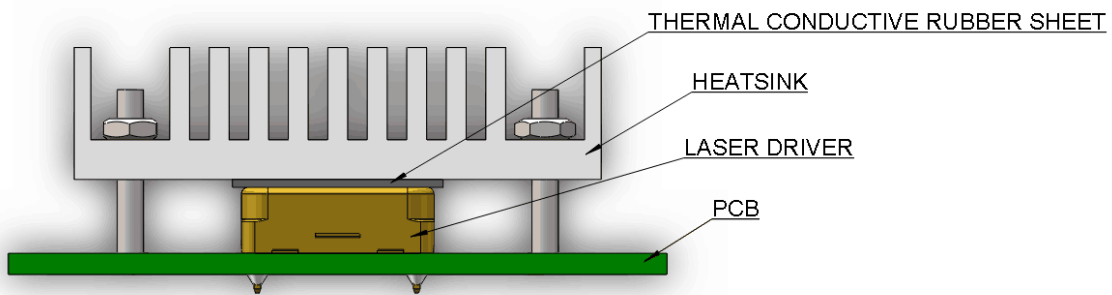

Figure 19.2 Transferring Heat with Heat Sink

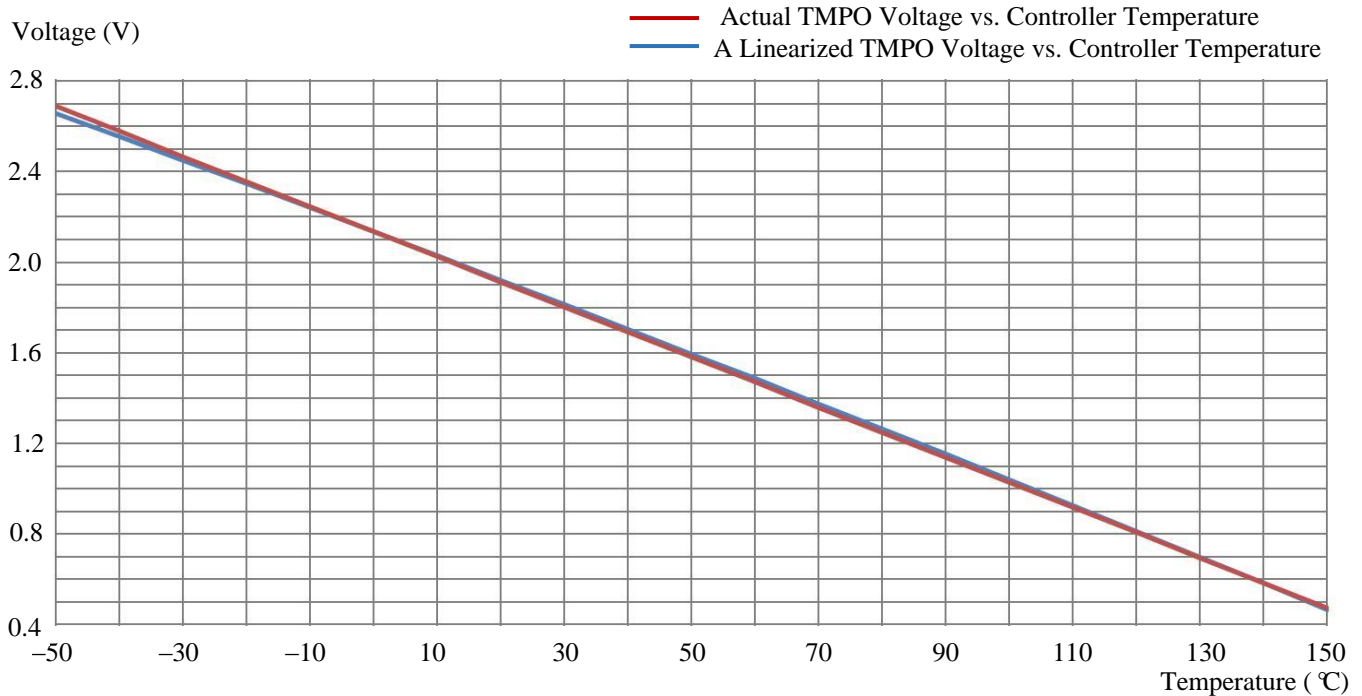

Figure 20. Controller Internal Temperature vs. TMPO Voltage

### MECHANICAL DIMENSIONS AND MOUNTING

The ATLS1.5A104 comes in 2 packages: through hole mount and surface mount. The former is often called DIP (Dual Inline package) or D (short for DIP) package and has a part number: ATLS1.5A104D, and the latter is often called SMT (Surface Mount Technology) or SMD (Surface Mount Device) package and has a part number: ATLS1.5A104S. See below Figure 21 and 22.

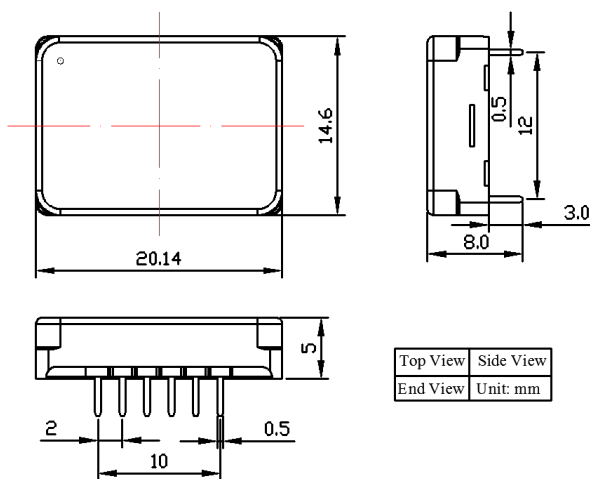

Figure 21. Dimensions of the DIP Package Controller

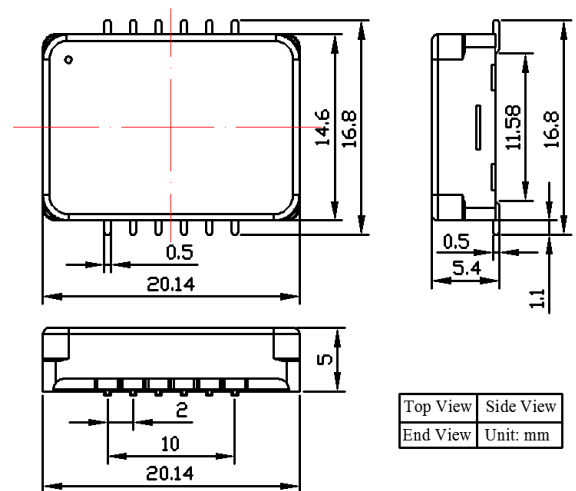

Figure 22. Dimensions of the SMT Package Controller

“Tent” (i.e. cover the entire via by the solder mask layer) all the vias under the controller, otherwise, the vias can be shorted by the bottom plate of the controller which is internally connected the ground.

Please notice that, in the recommended foot print for the DIP package, the holes for pin 2 to 6, and 8 to 12 have larger holes than needed for the pins. This arrangement will make it easier for removing the controller from the PCB, in case there is a rework needed. The two smaller

holes, for pin 1 and 7, will hold the controller in the right position.

It is also recommended to use large copper fills for VPS, PGND, and the LDC pins, and other pins if possible, to decrease the thermal resistance between the module and the supporting PCB, to lower the module temperature.

Please be notice that the SMT version cannot be soldered by reflow oven. It must be soldered manually.

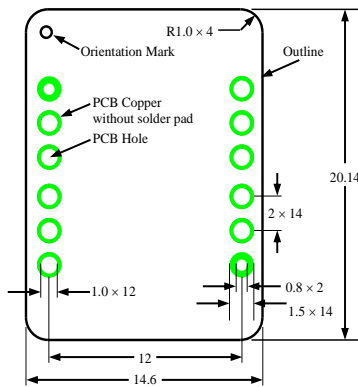

Figure 23. Top Side PCB Foot-print for the DIP Package  
Figure 23 shows the foot print which is seen from the top side of the PCB, therefore, it is a “see through” view.

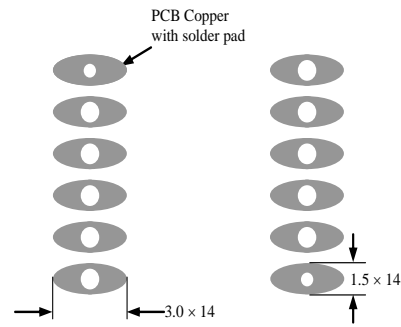

Figure 24. Top View of the Bottom Side PCB Foot-print  
Figure 24 shows the view of the bottom side PCB foot-print.

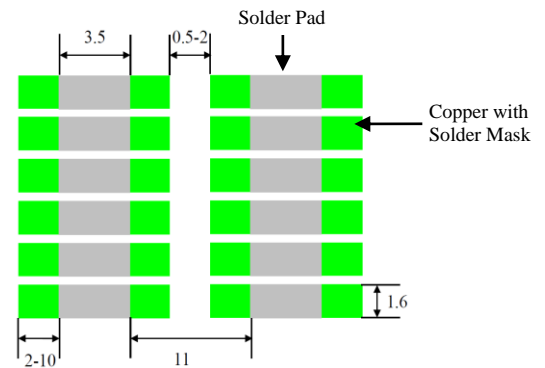

Figure 25. Top View of the Bottom Side of Surface Mount PCB Foot-print

**WARNING:** Both the surface mount and the through hole types of modules can only be soldered manually on the board by a solder iron of < 310 °C (590 °F), not go through a reflow oven process.

**NOTE:** The power supply may have overshoot, when happens, it may exceed the maximum allowed input voltage, 6V, of the controller and damage the controller permanently. To avoid this from happening, do the following:

1. Connect the controller solid well with the power supply before turning on the power.
2. Make sure that the power supply has sufficient output current. It is suggested that the power supply can supply 1.2 to 1.5 times the maximum current the controller requires.
3. When using a bench top power supply, set the current limit to >1.5 times higher than the maximum current the controller requires.
4. This laser driver can be evaluated by our evaluation board, [ATLS1A103DEV1.0](#).

### ORDERING INFORMATION

Part #	Description
ATLS1.5A104D	Controller in DIP package; there is a pull-up resistor of 1.5M resistor internally by default.
ATLS1.5A104D-PD	Controller in DIP package; there is a pull-down resistor of 1.5M resistor internally.
ATLS1.5A104S	Controller in SMT package; there is a pull-up resistor of 1.5M resistor internally by default.
ATLS1.5A104S-PD	Controller in SMT package; there is a pull-down resistor of 1.5M resistor internally.



PRICES

Quantity (pcs)	1~9	10~49	50~199	200~499	≥500
ATLS1.5A104D ATLS1.5A104D-PD ATLS1.5A104S ATLS1.5A104S-PD	\$79	\$74	\$69.5	\$65	\$61

NOTICE

- ATI warrants performance of its products for one year to the specifications applicable at the time of sale, except for those being damaged by excessive abuse. Products found not meeting the specifications within one year from the date of sale can be exchanged free of charge.
- ATI reserves the right to make changes to its products or to discontinue any product or service without notice, and advise customers to obtain the latest version of relevant information to verify, before placing orders, that information being relied on is current and complete.
- All products are sold subject to the terms and conditions of sale supplied at the time of order acknowledgment, including those pertaining to warranty, patent infringement, and limitation of liability. Testing and other quality control techniques are utilized to the extent ATI deems necessary to support this warranty. Specific testing of all parameters of each device is not necessarily performed, except those mandated by government requirements.
- Customers are responsible for their applications using ATI components. In order to minimize risks associated with the customers' applications, adequate design and operating safeguards must be provided by the customers to minimize inherent or procedural hazards. ATI assumes no liability for applications assistance or customer product design.
- ATI does not warrant or represent that any license, either express or implied, is granted under any patent right, copyright, mask work right, or other intellectual property right of ATI covering or relating to any combination, machine, or process in which such products or services might be or are used. ATI's publication of information regarding any third party's products or services does not constitute ATI's approval, warranty or endorsement thereof.
- IP (Intellectual Property) Ownership: ATI retains the ownership of full rights for special technologies and/or techniques embedded in its products, the designs for mechanics, optics, plus all modifications, improvements, and inventions made by ATI for its products and/or projects.