

Figure 1. The Top View of ATDC2934EV1



Figure 2. 3D View of ATDC2934EV1

FEATURES

- Versatile Interface for All Necessary Measurement Nodes
- Easy to Use

APPLICATIONS

Evaluating Step-Down DC/DC Converter ATDC2934.

INTRODUCTION

The ATDC2934 is a wide input range, high-efficiency, and high frequency DC-to-DC step-down switching

regulator. It is powered by a DC voltage between 5V to 42V and output current can go up to 0.6A, with a fixed switching frequency of 1.2MHz.

This evaluation board, ATDC2934EV1, is designed for evaluating the step-down DC/DC converter ATDC2934 conveniently. It is recommended to read this application note with the converter datasheet which provides more detail information about the specifications and application guidance for the converter.

DESCRIPTION

The ATDC2934EV1 Evaluation Board is consisted of a complete application circuit for driving a converter. It can set the output voltage. The output voltage of this board can be set to from 1.8V to 28V by adjusting a potentiometer. This evaluation board has numerous connection pads and terminal connectors for making connections with external components and instruments. Its physical photo of ATDC2934EV1 is shown in Figure 1 & Figure 2.

The silkscreen layer of the evaluation board is shown in Figure 3 with other top layers, including top silkscreen, top copper, top solder mask, and multilayer (vias). Figure 4 only shows the image of top silkscreen layer. There is no component in the bottom side of the board, so that there is no bottom silkscreen layer image.

There are solder pads on the left, top and the right edges of the board. These pads can be used for connecting the external instruments or components with and the connections can be made by either soldering wires or clipping by alligator clips.

There are 2 terminal blocks also located on the left and the right side of the board, their connectors are for the same nodes of the solder pads. See the silkscreen image in Figure 4.

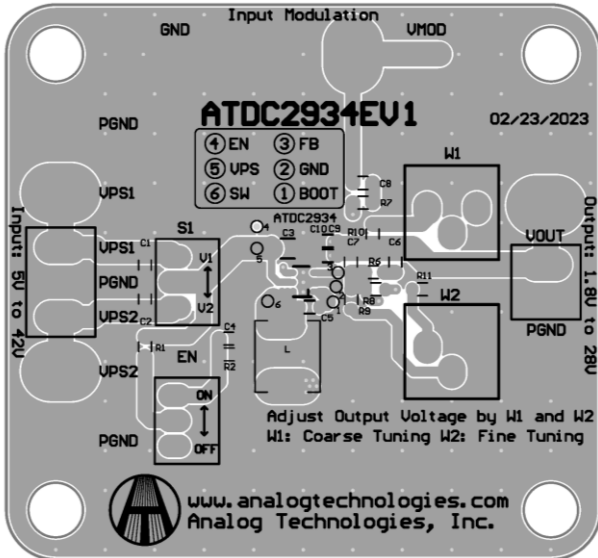

Figure 3. Top Silkscreen Layer with Other Top Layers

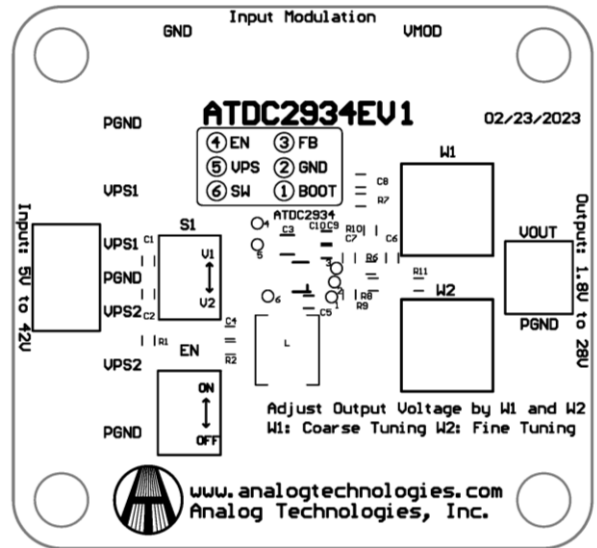

Figure 4. Top Silkscreen

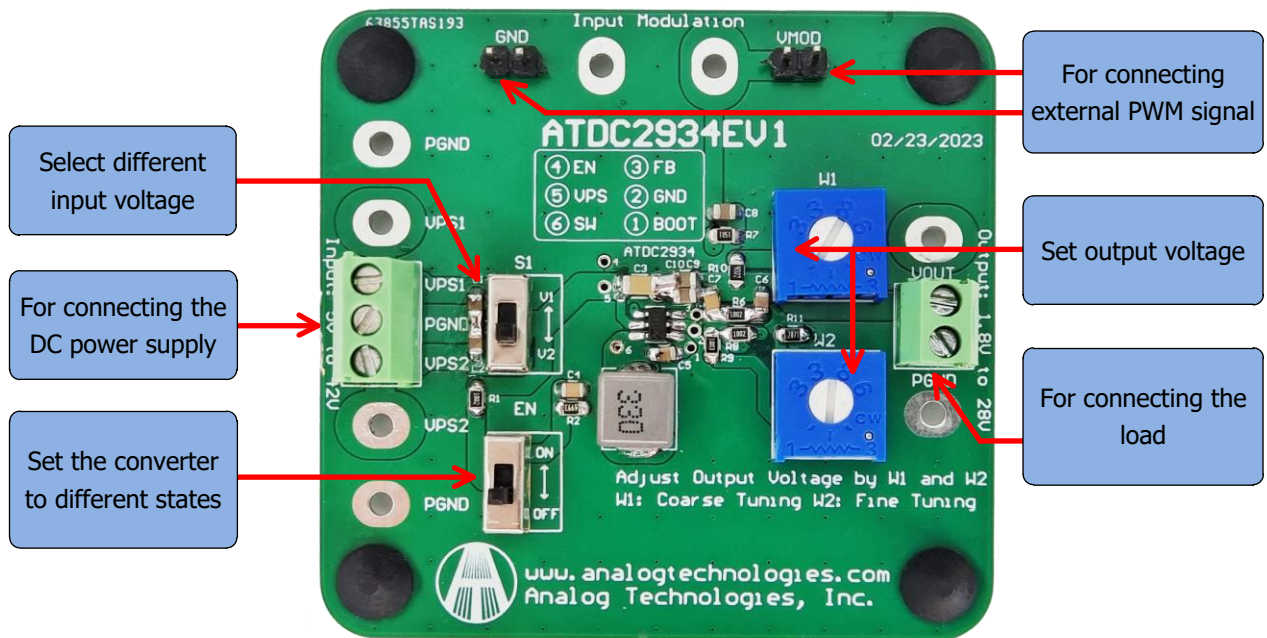

Figure 5. Board Description

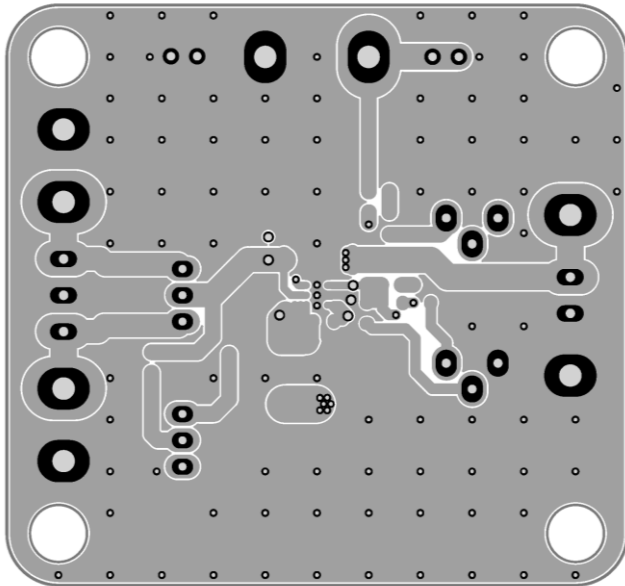

Figure 6. Top Layers without Top Screen Layer

Figure 6 shows the top layers without the silkscreen layer.

Figure 7 below shows the bottom layers, including bottom copper, bottom solder mask, and multilayer (vias). Please notice that this is a “see through” image from the top side.

Figure 8 shows the mirrored bottom layers which is a directly-seen image from the bottom side.

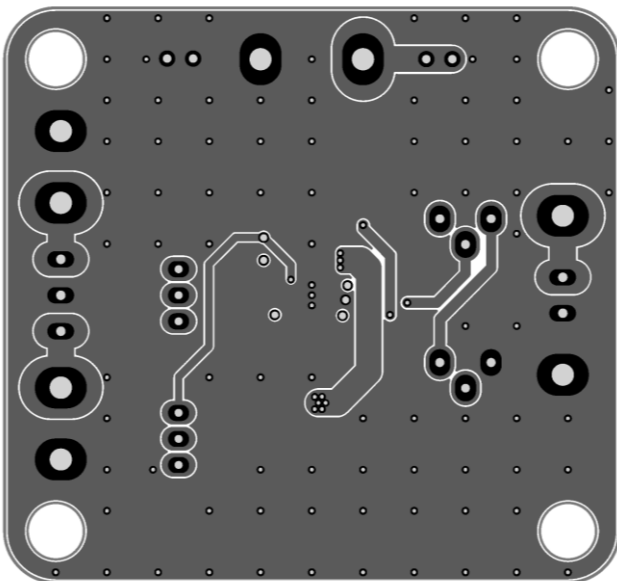

Figure 7. Bottom Layers

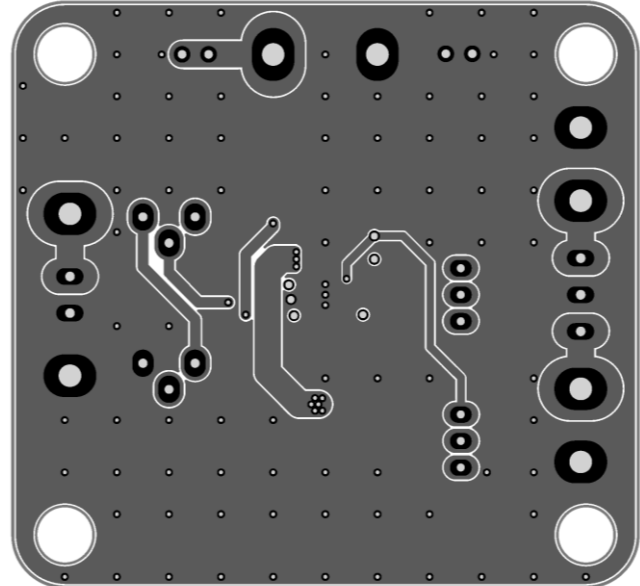

Figure 8. Mirrored Bottom Layers

The converter ATDC2934 is located in the center of the ATDC2934EV1 Evaluation Board. Some of the pins are connected to the connectors of the 2 terminal blocks, and/or the soldering pads on the edges of the board. The names of all these nodes are marked on the board.

GETTING STARTED

1. Find an external power supply and set the output voltage to a desired value. Turn it off, connect to the evaluation board, then turn power supply on. Do not connect or disconnect the power supply with the board when the power is on. The connection can be made by the terminal block on the left side of the PCB and run the wires to the external power supply.
2. To turn on the converter electronically, turn on the switch EN, the upper position; to turn the converter off, turn on this switch, the lower position.
3. Connect different external power supply by the switch S1. Connect the power supply VPS1, turn on the switch S1, the upper position; to connect the power supply VPS2, turn on this switch, the

lower position.

4. To add an external load, connect wires to terminal block on the right side of the PCB and run the wires to the external load.
5. To adjust the output voltage, turn W1 & W2, clock-wise to increase the output voltage; and vice versa. The output voltage can be adjusted from 1.8V to 28V.
6. To see the dynamic response of the output when the input voltage changes, use one channel of an oscilloscope to monitor VOUT.
7. Connect an external PWM signal to the solder pads for the input modulation on the top of the board. To see the dynamic response of the output when the load changes, use one channel of an oscilloscope to monitor LOAD test point, while using another channel monitor VOUT.

ATDC2934EV1 BILL OF MATERIALS

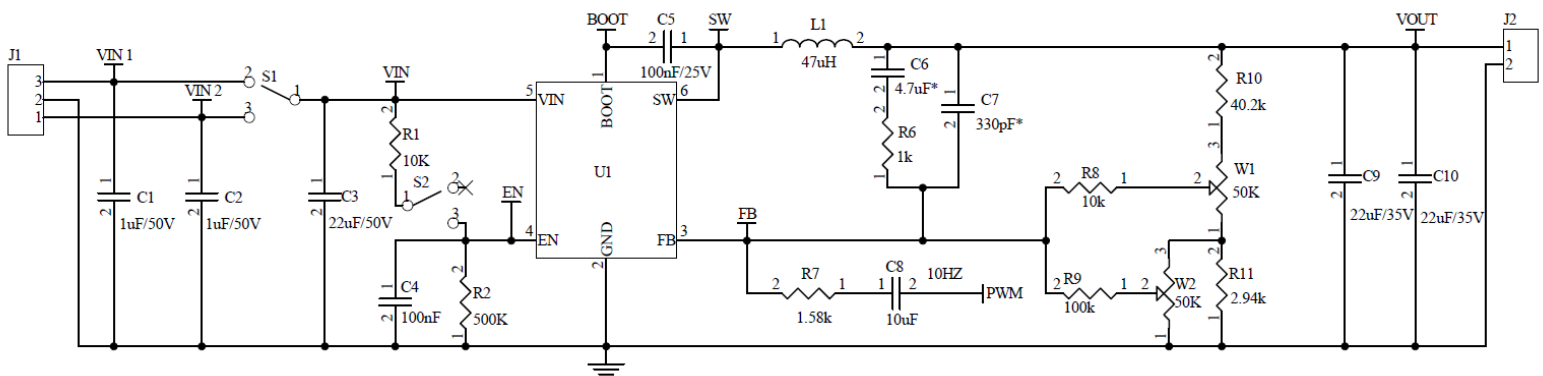

Designator	Value	Designator	Value
C1	1 μ F50V	R1	10k Ω
C2	1 μ F50V	R2	500k Ω
C3	22 μ F50V	R6	1k Ω
C4	100nF	R7	1.58k Ω
C5	100nF25v	R8	10k Ω
C6	4.7 μ F	R9	100k Ω
C7	330pF	R10	40.2k Ω
C8	10 μ F	R11	2.87k Ω
C9	22 μ F35V	W1	50k Ω
C10	22 μ F35V	W2	50k Ω
U1	ATDC2934	L1	47 μ H

EVALUATION BOARD SCHEMATIC



ORDERING INFORMATION

Table 3. Ordering Information

Part Number	Buy Now
ATDC2934EV1	 *  *

*: both  and  are our online store icons. Our products can be ordered from either one of them with the same pricing and delivery time.

NOTICE

1. It is important to carefully read and follow the warnings, cautions, and product-specific notes provided with electronic components. These instructions are designed to ensure the safe and proper use of the component and to prevent damage to the component or surrounding equipment. Failure to follow these instructions could result in malfunction or failure of the component, damage to surrounding equipment, or even injury or harm to individuals. Always take the necessary precautions and seek professional assistance if unsure about proper use or handling of electronic components.
2. Please note that the products and specifications described in this publication are subject to change without prior notice as we continuously improve our products. Therefore, we recommend checking the product descriptions and specifications before placing an order to ensure that they are still applicable. We also reserve the right to discontinue the production and delivery of certain products, which means that not all products named in this publication may always be available.
3. This means that while ATI may provide information about the typical requirements and applications of their products, they cannot guarantee that their products will be suitable for all customer applications. It is the responsibility of the customer to evaluate whether an ATI product with the specified properties is appropriate for their particular application.
4. ATI warrants its products to perform according to specifications for one year from the date of sale, except when damaged due to excessive abuse. If a product fails to meet specifications within one year of the sale, it can be exchanged free of charge.
5. ATI reserves the right to make changes or discontinue products or services without notice. Customers are advised to obtain the latest information before placing orders.
6. All products are sold subject to terms and conditions of sale, including those pertaining to warranty, patent infringement, and limitation of liability. Customers are responsible for their applications using ATI products, and ATI assumes no liability for applications assistance or customer product design.
7. ATI does not grant any license, either express or implied, under any patent right, copyright, mask work right, or other intellectual property right of ATI.
8. ATI's publication of information regarding third-party products or services does not constitute approval, warranty, or endorsement.
9. ATI retains ownership of all rights for special technologies, techniques, and designs for its products and projects, as well as any modifications, improvements, and inventions made by ATI.
10. Despite operating the electronic modules as specified, malfunctions or failures may occur before the end of their usual service life due to the current state of technology. Therefore, it is crucial for customer applications



that require a high level of operational safety, especially in accident prevention or life-saving systems where the malfunction or failure of electronic modules could pose a risk to human life or health, to ensure that suitable measures are taken. The customer should design their application or implement protective circuitry or redundancy to prevent injury or damage to third parties in the event of an electronic module malfunction or failure.