



Figure 1A. 3D View



Figure 1B. Top and Front View



Figure 1D. Back View



Figure 1C. Top and Side View



Figure 1E. Bottom View

FEATURES

- Built-in High Voltage Power Supply
- Compact Size: 9.15(L)×9.05(W)×2.4(H) inch
232.5(L)×230(W)×61(H) mm
- Bi-directional Output: ±1800V
- High Current Capability: Up to 20mA
- High Slew Rate: 2000V/μs@open load
540V/μs@250pF load
- Input Signal Voltage Range: ±10V
- Adjustable Bias Voltage Range: -10V ~ 10V
- Combined Control Voltage Range*: -10V ~ 10V
- Bandwidth: 15kHz @ Load = 100pF
10kHz @ Load = 250pF
8kHz @ Load = 500pF
3kHz @ Load = 1nF

*: Input Signal + Bias voltage = Combined Control Voltage

CUSTOMIZATION

If a higher bandwidth is needed, we can customize high voltage amplifiers with larger size and larger heat sink.

APPLICATIONS

This high voltage amplifier can be used for driving high voltage loads, including: piezoelectric transducers, mass spectrometers, electrostatic precipitators, electrophoresis experiments, high voltage storage capacitors, etc.

WARNINGS

1. Never touch the high voltage output by hand.
2. Do not place any foreign objects on the face plate.
3. Never connect the high voltage output to the low voltage side connectors. Keep them at least 2 inch (50mm) apart.
4. Before connecting or disconnecting high voltage output, make sure to turn off the amplifier power.

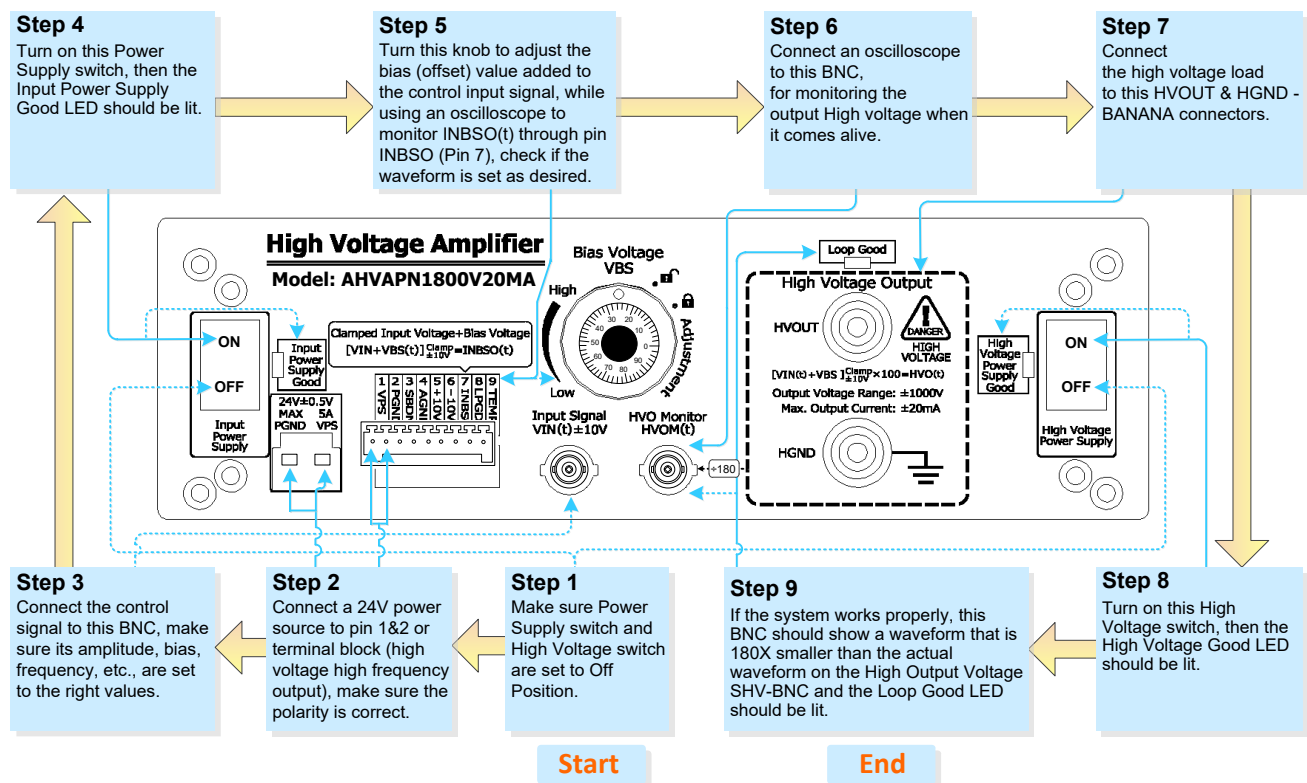

Figure 2. Operation Steps

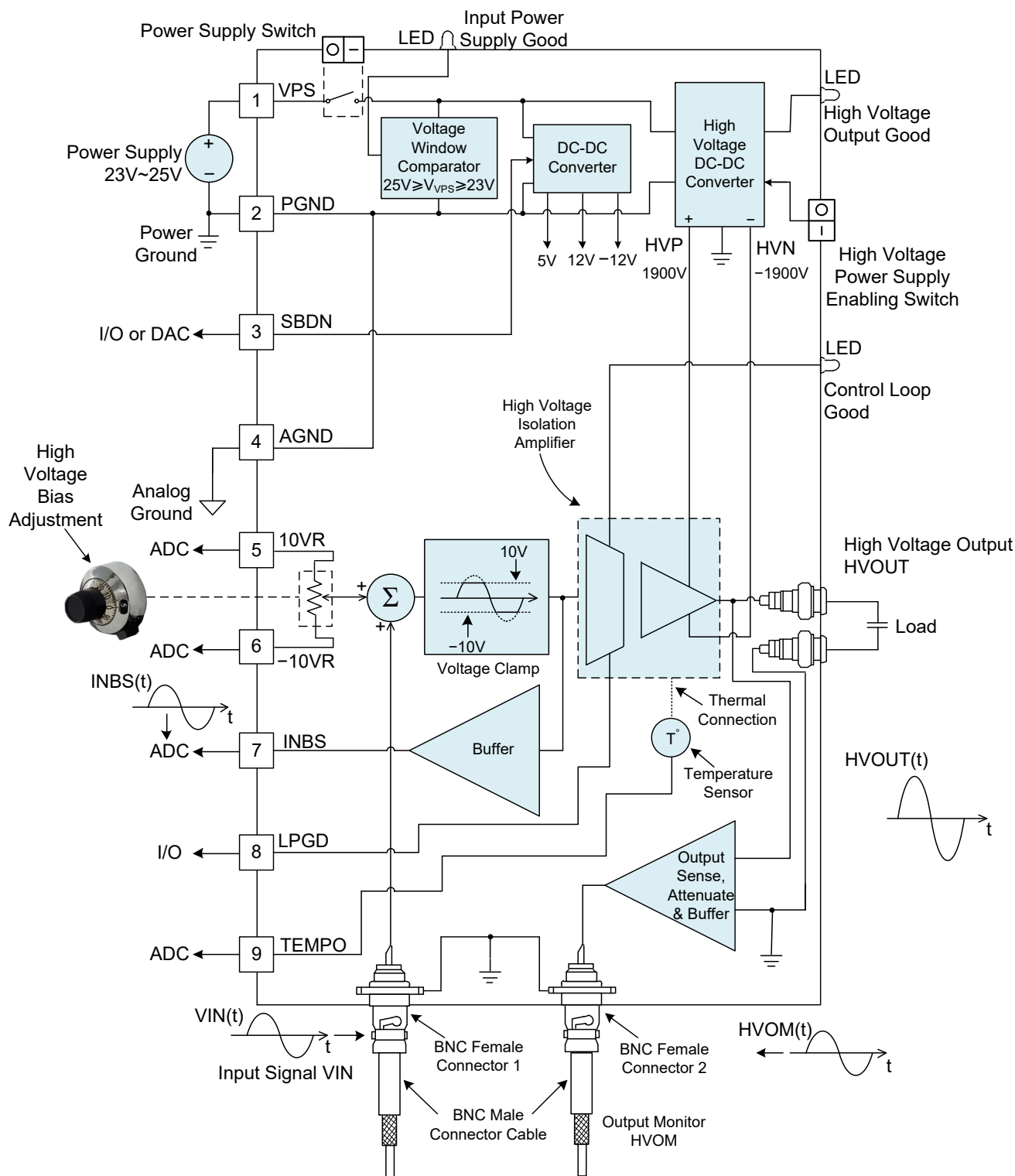

Figure 3. Block Diagram and Application Schematic



DESCRIPTION

The AHVAPN1800V20MABN is an electronic module for amplifying an analog input voltage into a high voltage output. Figure 1 shows its photos. It comes with a high voltage DC-DC converter, which converts the 24V input voltage into two output voltages: -1900V and +1900V. The analog input voltage, VIN(t), can be from -10V to +10V, the corresponding

output voltage, HVO(t), is from -1800V to +1800V. There are three LEDs indicating: 24V power supply is present and within an appropriate window: 23V to 25V, the high voltage power supply is outputting ±1900V outputs properly, and the control loop works properly, i.e. HVO(t) = 180×VIN(t).

Table 1. Terminal Block Pin Functions

Table with 4 columns: Pin #, Name, Type, Description. Rows include pins 1-9 and BNC 1-2, and OUTPUT HVOUT/HGND.



SPECIFICATIONS

Table 2. Characteristics (Test ambient temperature T_A = 25°C)

Parameter	Symbol	Test Conditions	Min.	Typ.	Max.	Units
Power Supply Input (Pin 1&2)						
Input Range	V _{VPS}		23	24	25	V
Input Current	I _{IN}		0		4	A
Maximum Input Power				100		W
Voltage Output						
Output Voltage	V _{OUT}		-1800		1800	V
Output Current	I _{OUT}		0		20	mA
Maximum Slew Rate		open load		2000		V/μs
		250pF load		540		V/μs
SBDN Pin (Pin 4)						
Off State	V _{SBDN-OFF}		0		0.4	V
	V _{SBDN-OFF-HI} Going up from Off to Standby threshold				2.1	V
	V _{SBDN-OFF-LOW} Going down from Standby to Off threshold		0.4			V
SBDN State	V _{SBDN-STANDBY}		2.1		2.51	V
	V _{SBDN-SB-HI} Going up from Standby to On threshold				2.64	V
	V _{SBDN-SB-LOW} Going down from On to Standby threshold		2.51			V
On State	V _{SBDN-ON}		2.64		V _{VPS}	V
SBDN Current	I _{SBDN}			10	20	μA
LPGD Pin (Pin 3)						
LPGD Voltage	V _{LPGD-LOW}	V _{DD} = 5V Sinking current = 8mA			0.6	V
	V _{LPGD-HI}	V _{DD} = 5V Sourcing current = 3.5mA	V _{DD} - 0.7			V
Voltage Reference	V _{REF}			-10/+10		V
Voltage Reference Current Range	I _{REF}		-20		20	mA
Voltage Noise	e _n p-p	0.1Hz to 10Hz		117		nVp-p
Voltage Noise Density	e _n	f = 1kHz		9		nV/√Hz

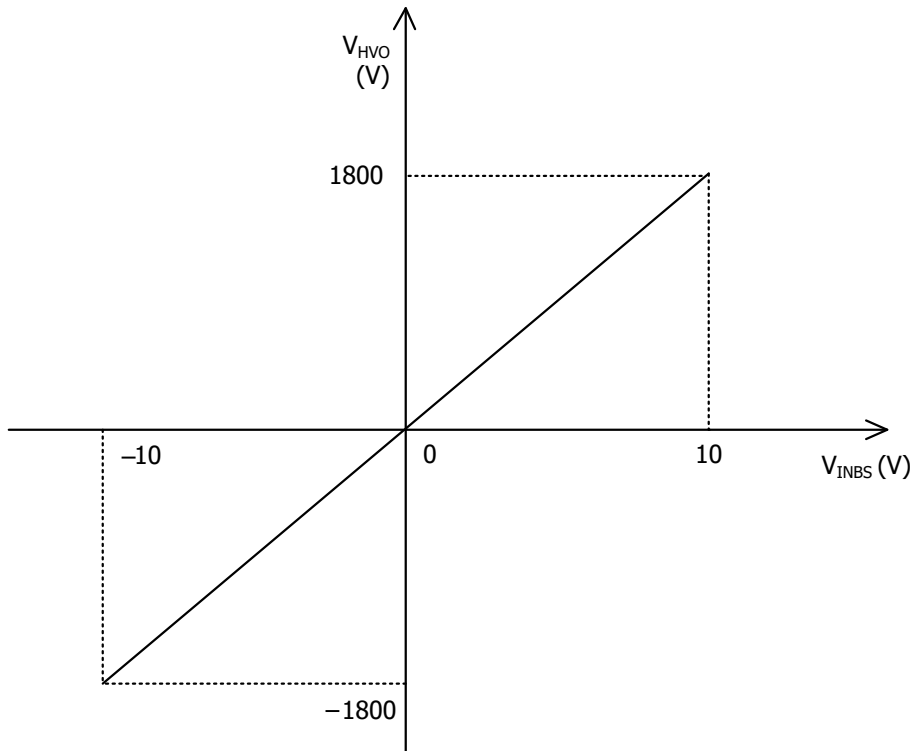

Figure 4. V_{INBS} vs. V_{HVO}

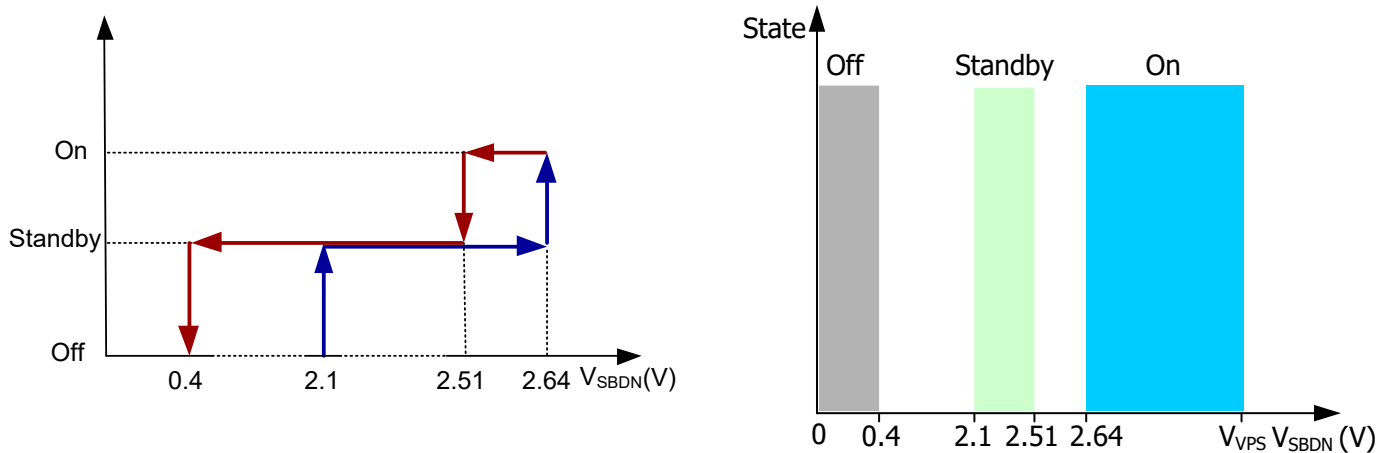

Figure 5. V_{SBDN} vs. Amplifier States

APPLICATIONS

A. Waveforms @ Load = 100pF, $V_{OUT} = \pm 1500V$



Figure 6. $f = 1kHz$



Figure 9. $f = 15kHz$



Figure 7. $f = 5kHz$



Figure 10. Rise time



Figure 8. $f = 10kHz$



Figure 11. Fall time



B. Waveforms @ Load = 250pF, $V_{OUT} = \pm 1500V$



Figure 12. $f = 1kHz$



Figure 15. Rise Time



Figure 13. $f = 5kHz$



Figure 16. Fall Time



Figure 14. $f = 10kHz$

C. Waveforms @ Load = 500pF, $V_{OUT} = \pm 1500V$



Figure 17. $f = 1kHz$



Figure 20. Rise Time



Figure 18. $f = 5kHz$



Figure 21. Fall Time



Figure 19. $f = 8kHz$

D. Waveforms @ Load = 1nF, $V_{OUT} = \pm 1500V$



Figure 22. $f = 1\text{kHz}$



Figure 24. Rise Time



Figure 23. $f = 3\text{kHz}$

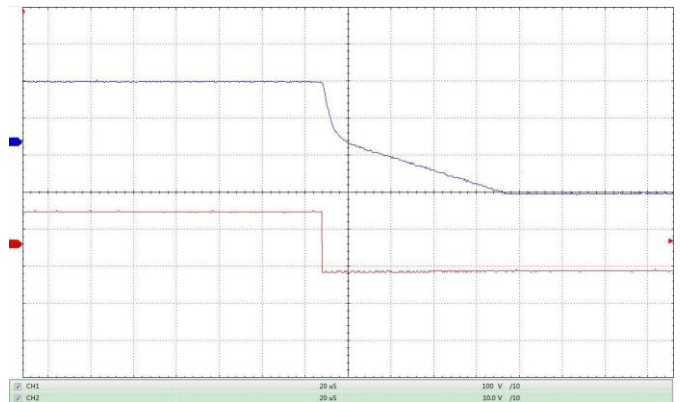

Figure 25. Fall Time

E. Waveforms @ Load = 10nF, $V_{OUT} = \pm 1500V$



Figure 26. $f = 1\text{kHz}$



Figure 27. $f = 500\text{Hz}$



Figure 28. $f = 100\text{Hz}$



Figure 30. Fall Time



Figure 29. Rise Time

F. Waveforms @ No load, $V_{OUT} = \pm 1800\text{V}$

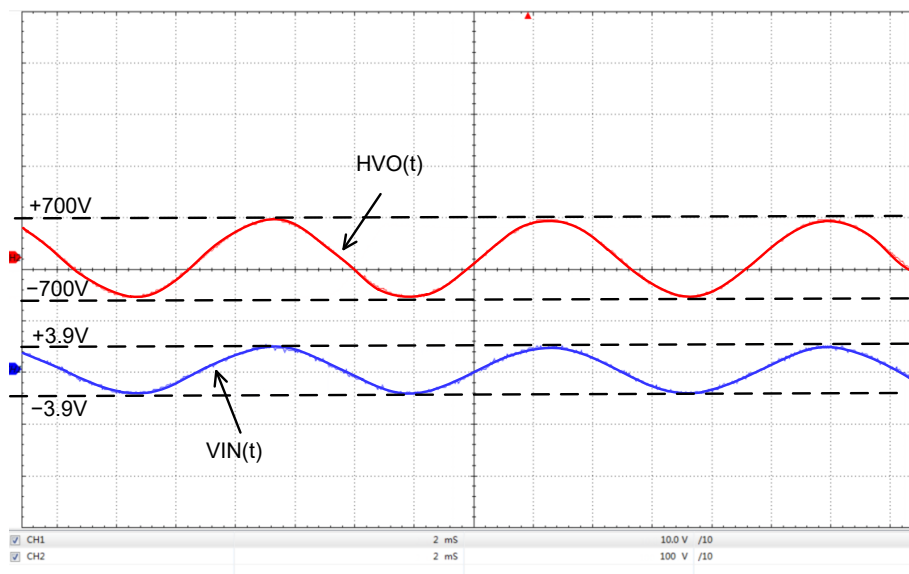

Figure 31. Input vs. Output with Sine Wave

PART NUMBER CONVENTION

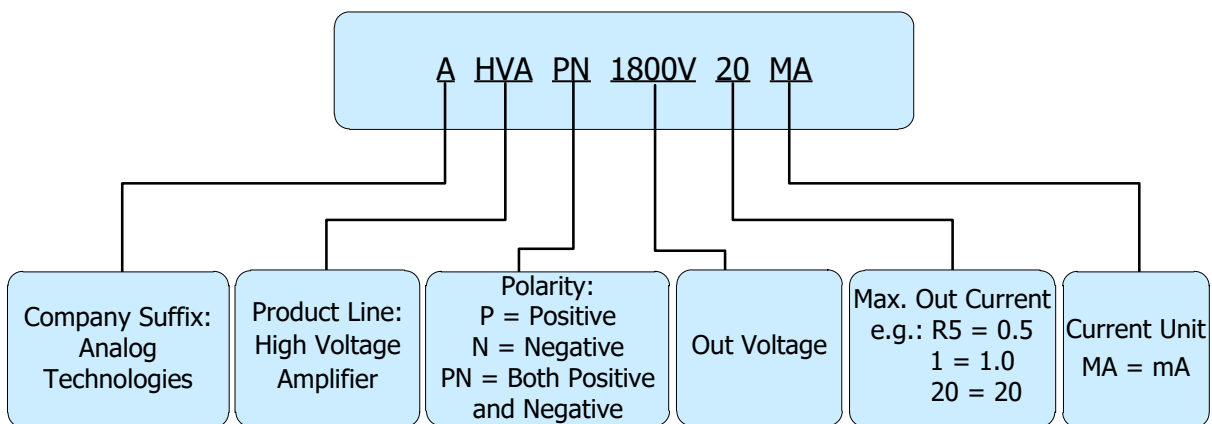

Figure 32. Part Number Convention

MECHANICAL DIMENSIONS

Figure 33 shows the dimensions of this high voltage amplifier.

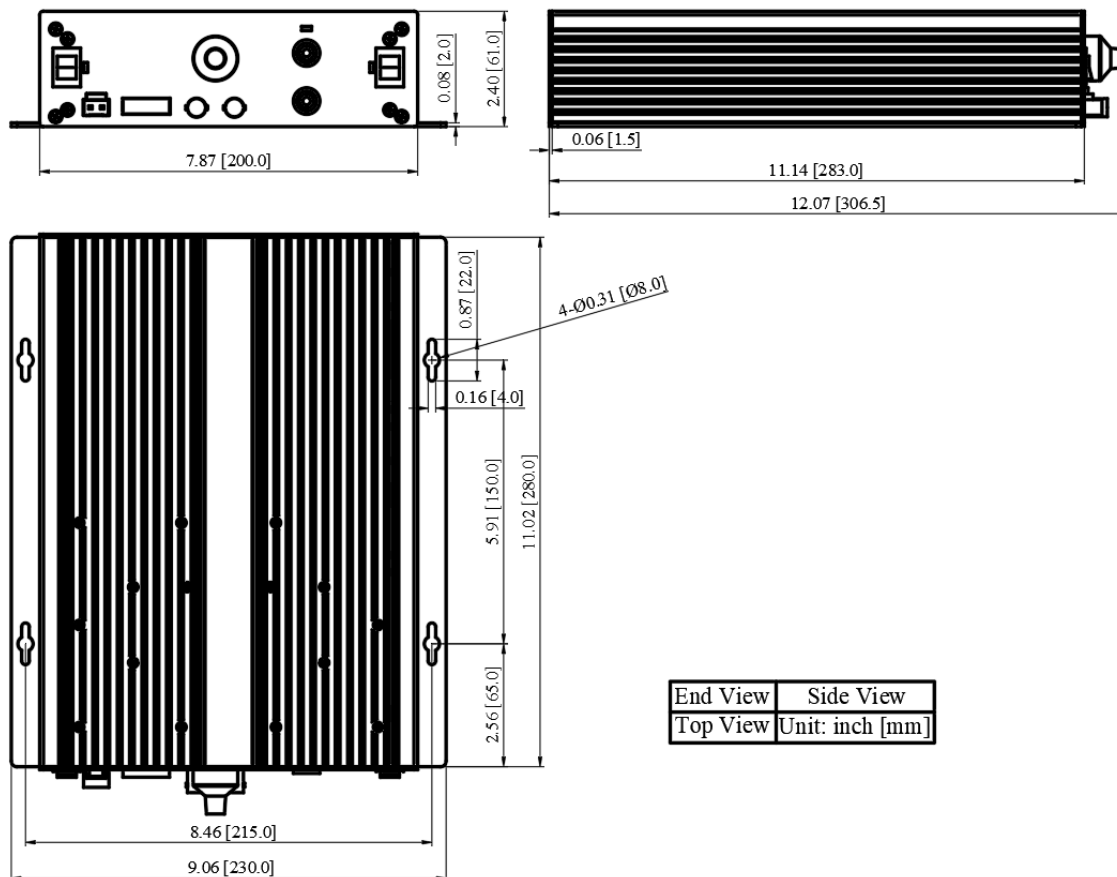

Figure 33. Dimensions of AHVAPN1800V20MABN

DETAILED ACCESSORIES LIST

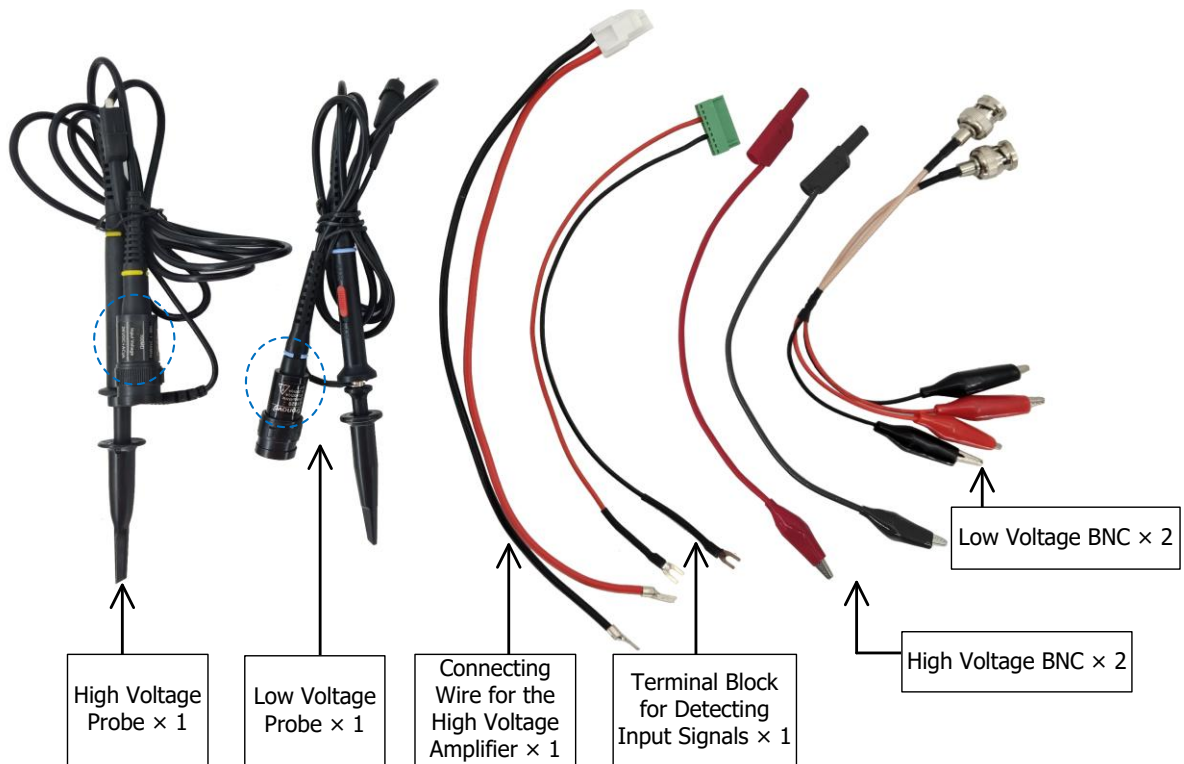

Figure 34. Accessories for the AHVAPN1800V20MABN

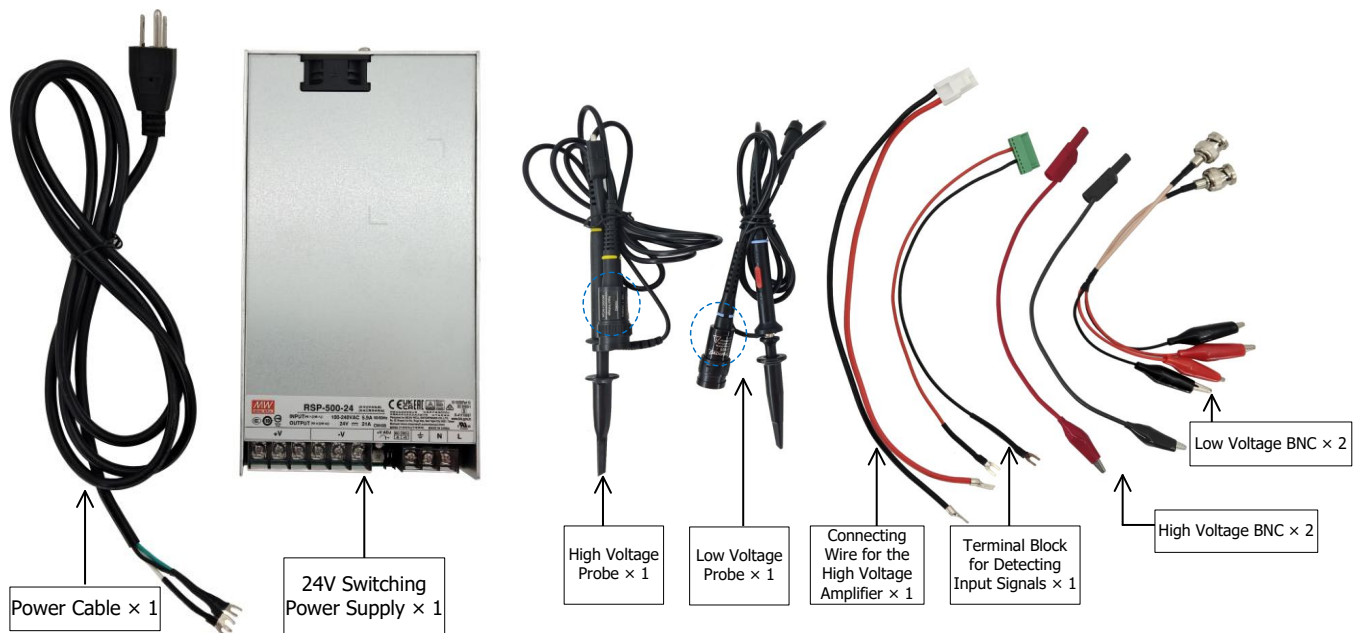

Figure 35. Accessories for the AHVAPN1800V20MABN including a 24V switching power supply

Note: This product is recommended to be used with a power supply of 24V and a current greater than 10A that does not allow overshoot. If you need to purchase, please contact us.



ORDERING INFORMATION

Table 3. Ordering Information

Part Number	Buy Now	Description
AHVAPN1800V20MABN	* *	±1800V 20mA high voltage amplifier
AHVAPN1800V20MABN + a 24V Switching Power Supply	* *	±1800V 20mA high voltage amplifier including a 24V switching power supply

*: both and are our online store icons. Our products can be ordered from either one of them with the same pricing and delivery time.

RELATED PRODUCTS

Table 4. Related Products

Part Number	Description
AHVAPN1800V10MA	±1800V 10mA high voltage amplifier
AHVAPN1000V10MA	±1000V 10mA high voltage amplifier
AHVAPN1000V20MA	±1000V 20mA high voltage amplifier
AHVAPN500V10MA	±500V 10mA high voltage amplifier
AHVAPN500V20MA	±500V 20mA high voltage amplifier

NOTICE

- ATI warrants its products to perform according to specifications for one year from the date of sale, except when damaged due to excessive abuse. If a product fails to meet specifications within one year of the sale, it can be exchanged free of charge.
- ATI reserves the right to make changes or discontinue products or services without notice. Customers are advised to obtain the latest information before placing orders.
- All products are sold subject to terms and conditions of sale, including those pertaining to warranty, patent infringement, and limitation of liability. Customers are responsible for their applications using ATI products, and ATI assumes no liability for applications assistance or customer product design.
- ATI does not grant any license, either express or implied, under any patent right, copyright, mask work right, or other intellectual property right of ATI.
- ATI's publication of information regarding third-party products or services does not constitute approval, warranty, or endorsement.
- ATI retains ownership of all rights for special technologies, techniques, and designs for its products and projects, as well as any modifications, improvements, and inventions made by ATI.