

Figure 1. The Physical Photos of Benchtop AHVA2000V20MA

**MAIN FEATURES**

- **Built-in High Voltage Converter**
- **Compact Size: 230(L)×252.0(W)×85.0(H) mm**
- **High Current Capability: Up to 20mA**
- **High Slew Rate: 200V/μs**
- **Input Voltage : 220VAC±10% 50Hz or 110VAC±10% 60Hz**
- **Wide Output Voltage Range:  $V_{OUT} = 0 \sim 2kV$**
- **Offset Voltage: 10V**
- **Bandwidth: Up to 20kHz**
- **Weight: 10.2lb (5.0kg)**

**APPLICATIONS**

High voltage amplifications for driving piezos and other high voltage loads.

**DESCRIPTION**

The AHVA2000V20MA is an electronic module for amplifying an analog input voltage into a high voltage output. Figure 1 shows its physical photos. It comes with a high voltage AC-DC converter, which converts the 110VAC/220VAC input voltage into a 0V to 2kV output voltage. The analog output voltage can swing almost from 0V to 2kV when it is powered by an 110VAC/220VAC power supply. There is an LCD display indicating if the amplifier works properly.

**OPERATION**

The switch on the right of the panel is the power switch. ON is on and OFF is off. Turn on the switch to set the input control voltage. 0V to 10V input voltage corresponds to 0V to 2000V output voltage. INPUT is the input pin. The Input+Offset Monitor is the input monitor pin. Meanwhile, the LCD will also display the corresponding input waveform. The high voltage output control switch and the output BNC are on the right of the panel. After the setting, turn on the high voltage switch to monitor the output.

**SPECIFICATIONS**

Table 1. Characteristics (Test ambient temperature  $T_A = 25^\circ C$ )

Parameter	Symbol	Test Conditions	Min.	Typ.	Max.	Units
Output Voltage	$V_{OUT}$		0		2000	V
Output Current	$I_{OUT}$			20		mA
Input voltage	$V_{IN}$			110/220		VAC
DC Voltage Gain	G			200		V/V
Slew Rate	SR			200		V/us
Large Signal Bandwidth	GBW			20		kHz
Output Impedance	$R_{OUT}$			50		$\Omega$
Reference Voltage	$V_R$			10		V

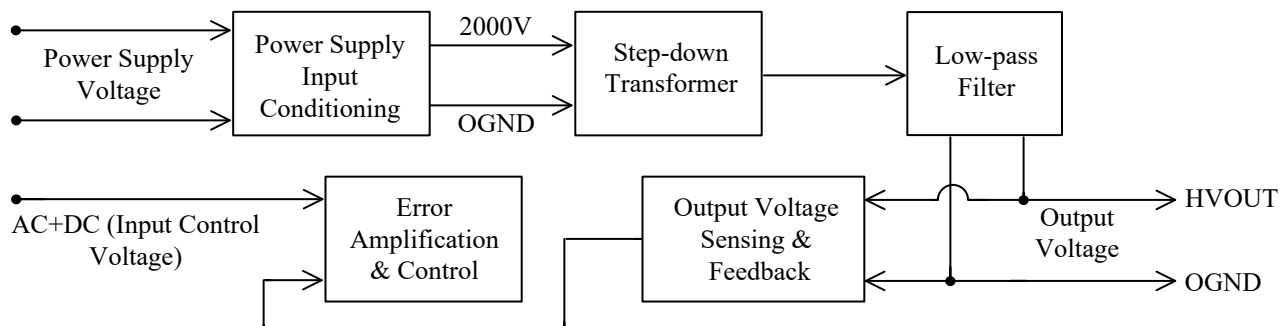

Figure 2. Block Diagram



ORDERING INFORMATION

Table 2. Part Number

Part Number	Description
AHVA2000V20MA	2000V bench top high voltage amplifier

Table 3. Unit Price

Quantity (pcs)	1 – 4	5 – 8	9 – 12	13 – 16	17 – 20	≥21
Unit Price	\$3500	\$3400	\$3300	\$3150	\$3000	\$2900

NOTICE

- ATI warrants performance of its products for one year to the specifications applicable at the time of sale, except for those being damaged by excessive abuse. Products found not meeting the specifications within one year from the date of sale can be exchanged free of charge.
- ATI reserves the right to make changes to its products or to discontinue any product or service without notice, and advise customers to obtain the latest version of relevant information to verify, before placing orders, that information being relied on is current and complete.
- All products are sold subject to the terms and conditions of sale supplied at the time of order acknowledgment, including those pertaining to warranty, patent infringement, and limitation of liability. Testing and other quality control techniques are utilized to the extent ATI deems necessary to support this warranty. Specific testing of all parameters of each device is not necessarily performed, except those mandated by government requirements.
- Customers are responsible for their applications using ATI components. In order to minimize risks associated with the customers’ applications, adequate design and operating safeguards must be provided by the customers to minimize inherent or procedural hazards. ATI assumes no liability for applications assistance or customer product design.
- ATI does not warrant or represent that any license, either express or implied, is granted under any patent right, copyright, mask work right, or other intellectual property right of ATI covering or relating to any combination, machine, or process in which such products or services might be or are used. ATI’s publication of information regarding any third party’s products or services does not constitute ATI’s approval, warranty or endorsement thereof.
- IP (Intellectual Property) Ownership: ATI retains the ownership of full rights for special technologies and/or techniques embedded in its products, the designs for mechanics, optics, plus all modifications, improvements, and inventions made by ATI for its products and/or projects.