



Figure 1. Physical Photo of A2UHVAC3KV50MAIRM

## FEATURES

- High precision
- High efficiency
- High output voltage stability
- Linear modulation of output voltage
- Overcurrent protection
- Isolation between Input and Output
- Arc and Short circuit protection
- Digital display for output voltage and current
- OEM Customization Available

## APPLICATIONS

A2UHVAC3KV50MAIRM, is designed for achieving AC-DC conversion from AC voltage to high DC voltage isolated power supply. This series high voltage power supply is rack-mounted, and is mainly used in ion beam injection, semiconductor technology, electron beam welding, capacitor charging, high power radio frequency transmitter, accelerator, CW laser, high voltage insulation test, lithography technology, X-ray system, electrostatic applications, scientific experiments, industrial applications and other fields.

## DESCRIPTION

The power supply comes with high stability, high reliability, high accuracy of output voltage regulation, and continuously adjustable output voltage; low time drift and temperature

drift; it adopts modular design inside the power supply, with protection against overvoltage, overcurrent, and arcing; the control interface uses industrial interface, with industrial design from circuit schematic to the overall structure; high integration and high detection accuracy; it has functions such as start-up soft-start and control; convenient for control, easy operation; the internal transformation of the power supply can be made based on the actual needs of the customer.

## SAFETY PRECAUTIONS

High voltage power supply must be connected to ground reliably.

Do not touch the high voltage wire, unless the high voltage power supply is powered off, and the load and internal capacitors are fully discharged.

When the high voltage power supply is powered off, wait for another 5 minutes for fully discharging all the capacitors inside the power supply.

Do not operate the power supply in humid environment, and do not connect the operator to ground.

The internal protection circuit is provided in the high voltage power supply, but the high voltage short circuit shall be avoided.

Make sure the circuit is insulated perfectly, especially between the high voltage output and the surroundings so as to avoid electronic shock.

**SPECIFICATIONS**

Table 1. Characteristics.

 $T_A = 25^\circ\text{C}$ , unless otherwise noted

Parameter		Symbol	Condition	Min.	Typ.	Max.	Unit/Note
AC Input Voltage		$V_{VPS}$		110	120	130	$V_{AC}$
Quiescent Input Current		$I_{INQQ}$	$I_{OUT} = 0\text{mA}$	350	400	450	mA
Full Load Input Current		$I_{INFLD}$	$I_{OUT} = 50\text{mA}$	1.3	1.4	1.5	A
Output Voltage		$V_{OUT}$	$I_{OUT} = 0 \sim 50\text{mA}$	0		3000	V
Maximum Output Current		$I_{OUTMAX}$	Full load			50	mA
Ripple			Bandwidth = 1MHz		<0.1		% $V_{P-P}$
Isolation Voltage					5000		V
Load					60		K $\Omega$
Potentiometer Adjustment				10k potentiometer or remote control 0 ~ +5V			
Output Modulation Linearity					<0.1		%
Voltage Regulation	Load		$I_{OUT} = 0 \sim 50\text{mA}$		<0.1		%
	Input		$V_{VPS} = 110\text{V} \sim 130\text{V}$		< $\pm$ 0.1		%
Current Regulation	Load		$I_{OUT} = 0 \sim 50\text{mA}$		<0.1		%
	Input		$V_{VPS} = 110\text{V} \sim 130\text{V}$		<0.1		%
Full Load Efficiency		$\eta$			$\geq 70$		%
Temperature Coefficient		$TCV_O$	0 ~ 50°C		<0.1		%/°C
Time Drift	Short Time Drift		After 30 minute's warming up		<0.1		%/ min
	Long Time Drift				<0.5		%/h
Output Voltage Temperature Stability			0 ~ 50°C		< $\pm$ 0.1		%
Operating Temperature Range		$T_{opr}$		0		50	°C
Storage Temperature Range		$T_{stg}$		-20		85	°C
Humidity				20%-85% relative humidity non-condensing			
External Dimensions				482.5×350×88			mm
				19×13.78×3.46			inch
Weight					10		kg
					22.05		lbs
					352.74		Oz



PANEL INSTRUCTIONS

Front Panel

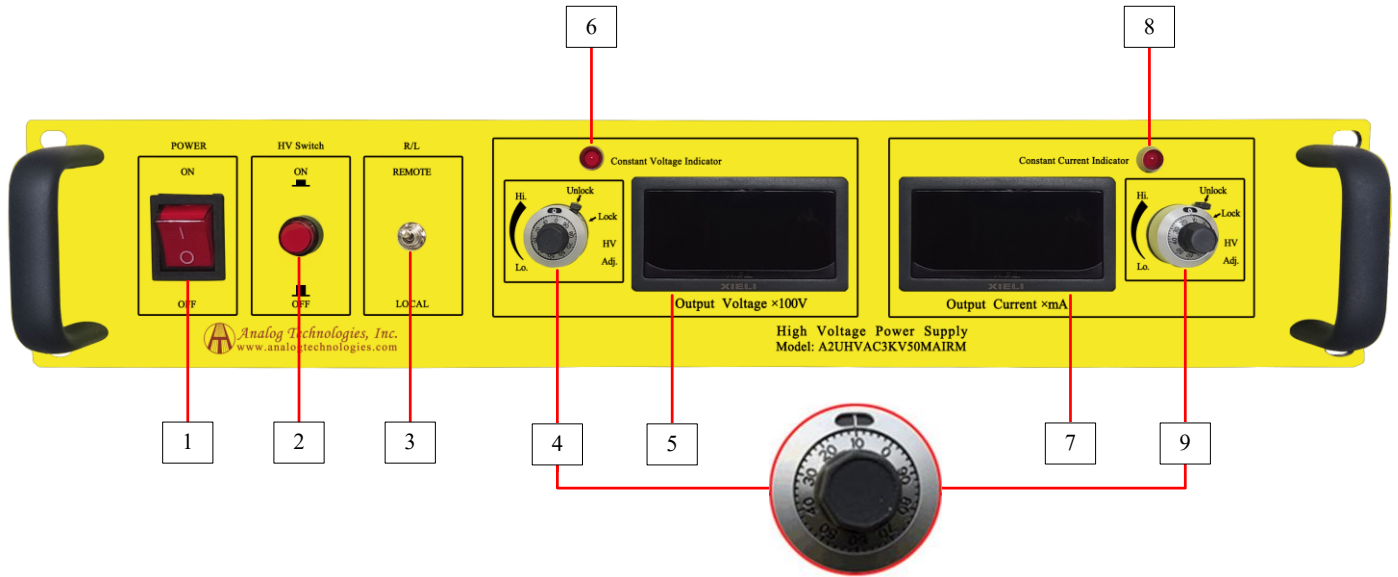

Figure 2. Front Panel

Table 2. Definitions of front panel keys

No.	Signal	Signal Parameters
1	Power	When the power is turned on, the indicator is on; when the power is turned off, the indicator is off.
2	HV Switch	High voltage turned on, the indicator is on; High voltage turned off, the indicator is off.
3	R/L	When the switch is in Remote, it is controlled remotely; when the switch is in Local, it is controlled locally.
4	HV Adjustment	10-turn potentiometer for adjusting output voltage. Rotate it clockwise to increase the output voltage, and the potentiometer resistance = the corresponding scale $\times 10\Omega$ . For example, when the scale is 10, and the frame above the scale shows 1 (1k $\Omega$ ), then the resistance = $10 \times 10\Omega + 1k\Omega = 1.1k\Omega$ , and the like. HV output: 1.5m long connection wire outputs 3kV.
5	Output Voltage Display	Digital display for the output voltage. Do not show if the voltage is positive or negative.
6	Constant Voltage Indicator	When it is working under constant voltage, the indicator is on.
7	Output Current Display	Digital display for the output current. The actual output current = the reading $\times$ mA.



8	Constant Current Indicator	When it is working under constant current, the indicator is on.
9	Current Adjustment	10-turn potentiometer for adjusting output voltage. Rotate it clockwise to increase the output voltage, and the potentiometer resistance = the corresponding scale $\times 10\Omega$ . For example, when the scale is 10, and the frame above the scale shows 1 (1k $\Omega$ ), then the resistance = $10 \times 10\Omega + 1k\Omega = 1.1k\Omega$ , and the like.  HV output: 1.5m long connection wire outputs 50mA.

Back Panel

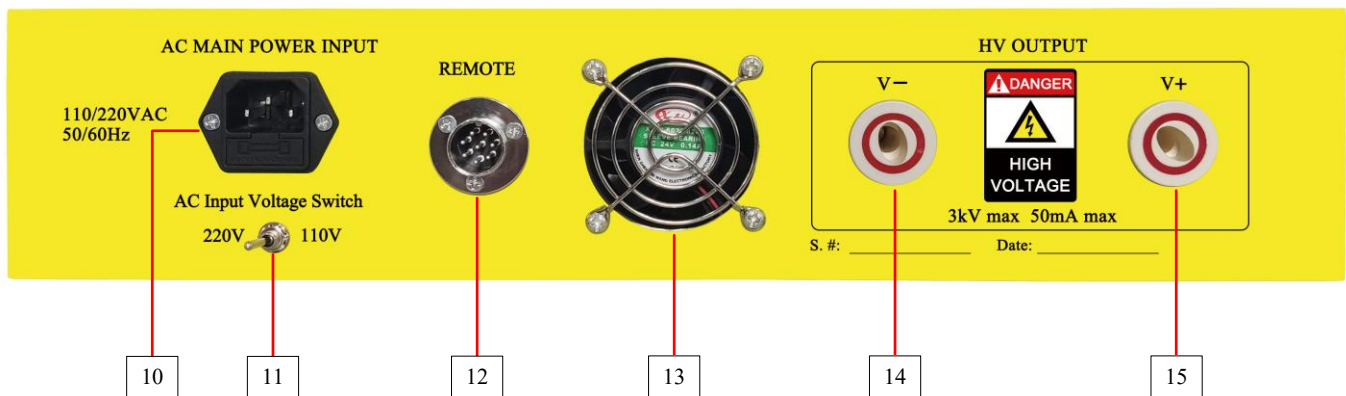

Figure 3. Front Panel

Table 3. Definitions of back panel function keys

No.	Signal	Signal Parameters
10	AC Main Power Input	AC input 110V/220V, 50/60Hz connector.
11	AC Input Voltage Switch	Before connecting the AC voltage, make sure the selected input voltage is consistent with the connected voltage, e.g., when the switch is in 110V input, the connected AC voltage can be 100V to 130V.
13	Remote	8-pin connector. Refer to the following Table 4 and Figure 6 for remote control function.
14	Ventilation Hole	Ventilation hole of fan or air.
15	Negative Output	See Figure 6 for the output connection.
16	Positive Output	See Figure 6 for the output connection.



Figure 4. Back panel connection

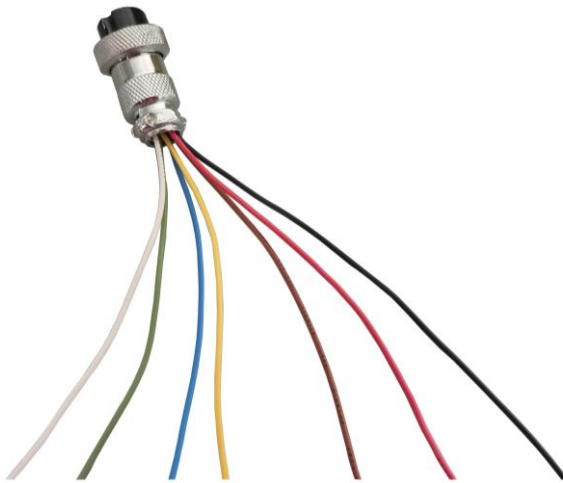

Figure 5. 8-pin Connector



Figure 6. High Voltage Output Lead

Table 4. 8-pin connector.

Pin	Signal	Signal Parameters	Lead Color
P1	Remote Voltage Program In	0 to 5V=0 to 100% rated output.	White
P2	Remote Current Program In	0 to 5V=0 to 100% rated output.	Yellow
P3	Voltage Monitor	0 to 5V=0 to 100% rated output.	Green
P4	Current Monitor	0 to 5V=0 to 100% rated output.	Blue
P5	Shutdown	A logic low <0.8V or a 0V on the SDN pin will turn the device off. When SDN is in logic high >1.2V or left unconnected, it is working well. The maximum voltage allowed on the SDN pin is 5V.	Brown
P6	GND	Signal ground	Black
P7	Voltage Reference	+5VDC Reference I <sub>REF</sub> < 5mA	Red
P8	NC	No connection	

**Note: Please separate the wires of the remote control end or connect the tails correspondingly. Then connect it with the machine to avoid short circuit damages to internal components.**



About Isolation Output

1. The isolated high voltage power supply has a positive output pole and a negative output pole.
2. The output of the isolated high voltage power supply is independent.
3. The positive and negative poles of the isolated high voltage power supply and the input end are isolated from each other, with a voltage resistance of 5kV.
4. When using, the positive or negative pole can be grounded (or the earth). if it is the power supply of the chassis, one of the positive or negative poles can be grounded (connected to the chassis cover).
5. When the negative pole is grounded, the output is positive voltage; when the positive pole is grounded, the output is negative voltage.
6. Multiple isolated high voltage power supplies can be used in series, and the voltage can be added.
7. Output connection:

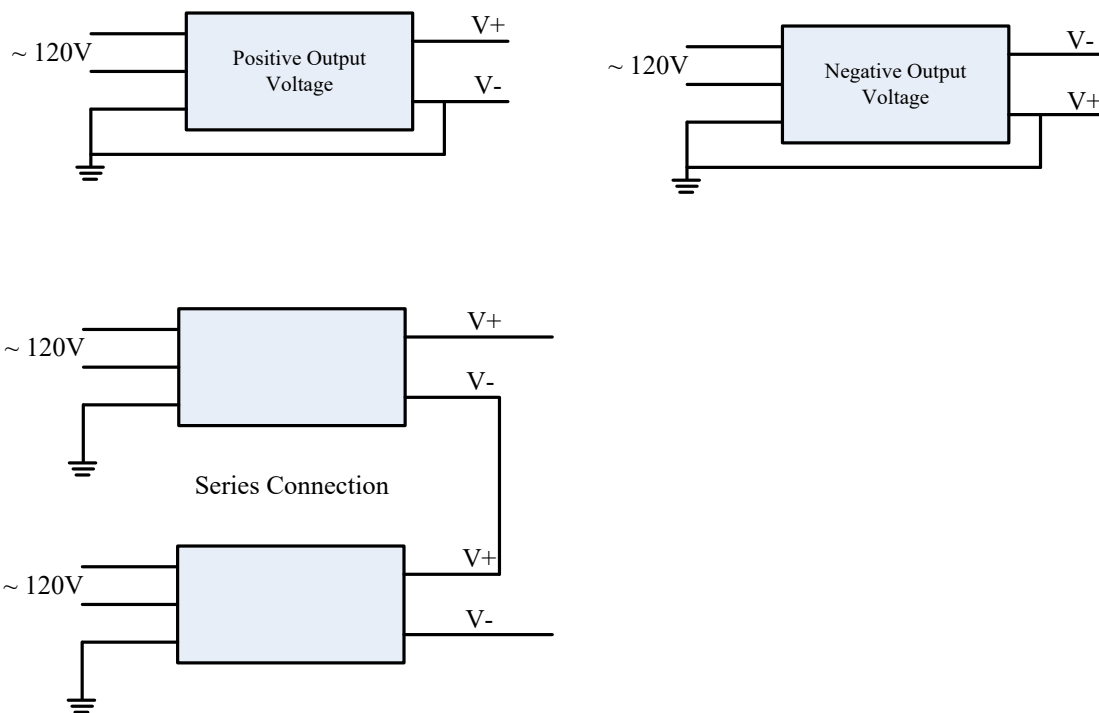

Figure 7. Wiring Connection



NAMING INSTRUCTIONS

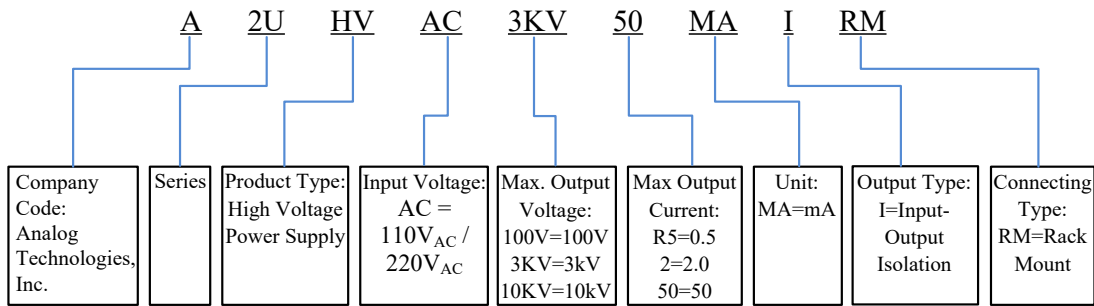

Figure 8. Naming Rules of A2UHVAC3KV50MAIRM

TESTING DATA

High voltage power supply testing data (Test condition: the load is 60kΩ).

The measured output voltage, V<sub>OUT</sub>, corresponding to the control port input voltage, V<sub>CTRL</sub>, is shown in Figure 9.

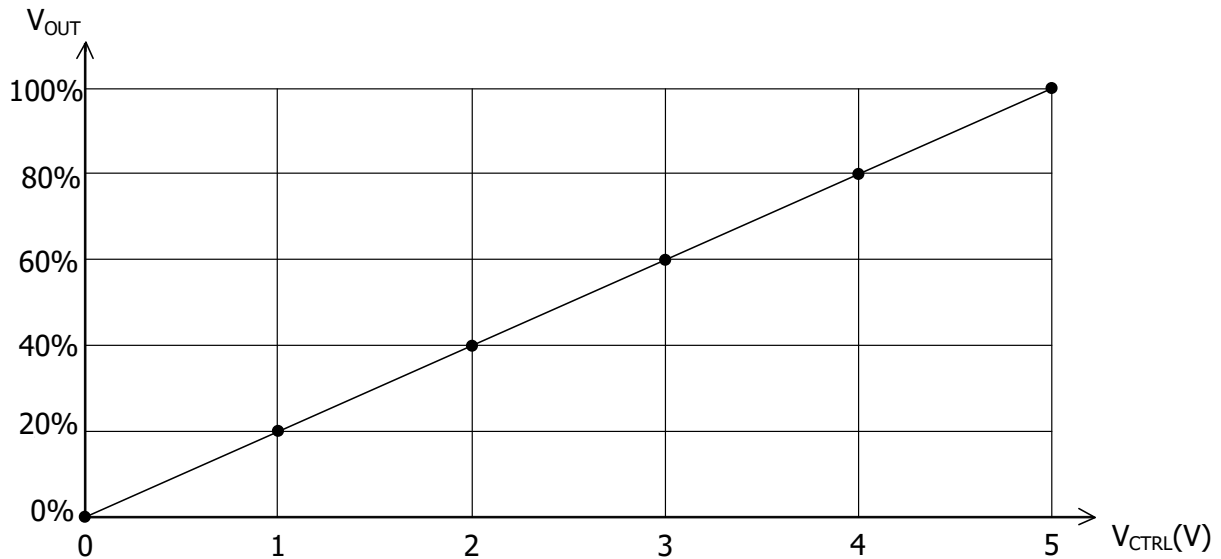

Figure 9. V<sub>CTRL</sub> vs. V<sub>OUT</sub>



**DIMENSIONS**

Dimension of A2UHVAC3KV50MAIRM.

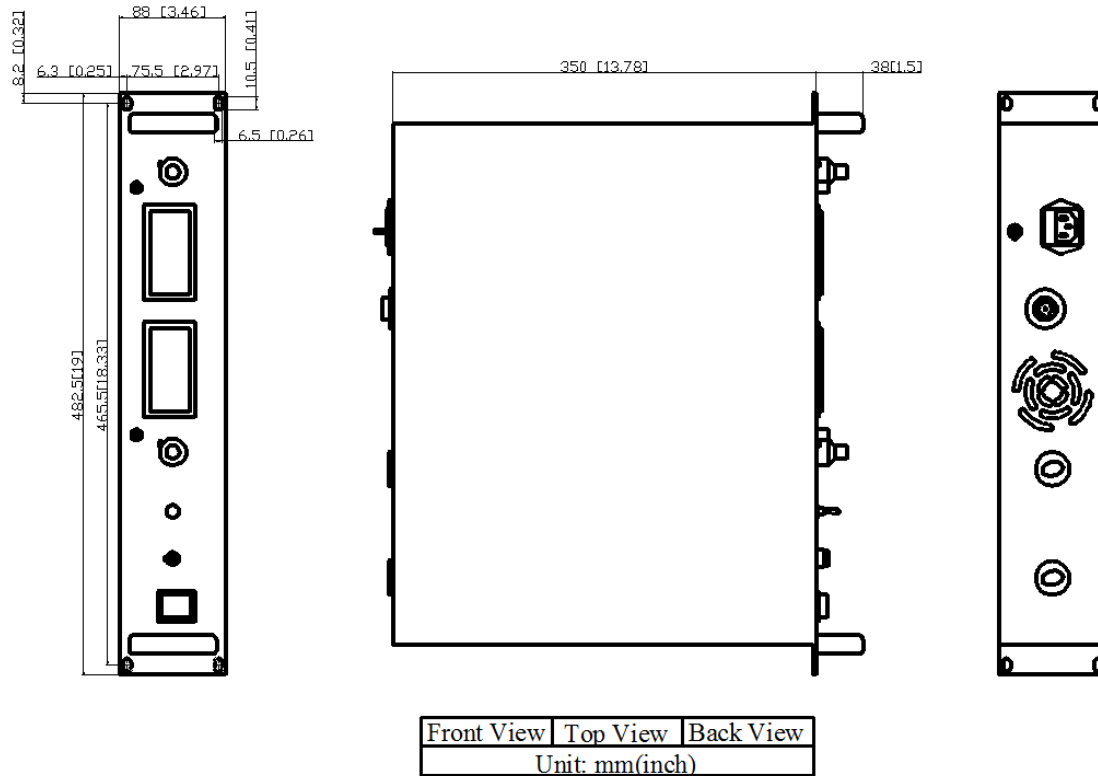

Figure 9. Dimensions for A2UHVAC3KV50MAIRM

**NOTICE**

- ATI warrants performance of its products for one year to the specifications applicable at the time of sale, except for those being damaged by excessive abuse. Products found not meeting the specifications within one year from the date of sale can be exchanged free of charge.
- ATI reserves the right to make changes to its products or to discontinue any product or service without notice, and advise customers to obtain the latest version of relevant information to verify, before placing orders, that information being relied on is current and complete.
- All products are sold subject to the terms and conditions of sale supplied at the time of order acknowledgment, including those pertaining to warranty, patent infringement, and limitation of liability. Testing and other quality control techniques are utilized to the extent ATI deems necessary to support this warranty. Specific testing of all parameters of each device is not necessarily performed, except those mandated by government requirements.
- Customers are responsible for their applications using ATI components. In order to minimize risks associated with the customers' applications, adequate design and operating safeguards must be provided by the customers to minimize inherent or procedural hazards. ATI assumes no liability for applications assistance or customer product design.



5. ATI does not warrant or represent that any license, either express or implied, is granted under any patent right, copyright, mask work right, or other intellectual property right of ATI covering or relating to any combination, machine, or process in which such products or services might be or are used. ATI's publication of information regarding any third party's products or services does not constitute ATI's approval, warranty or endorsement thereof.
6. IP (Intellectual Property) Ownership: ATI retains the ownership of full rights for special technologies and/or techniques embedded in its products, the designs for mechanics, optics, plus all modifications, improvements, and inventions made by ATI for its products and/or projects.