



Figure 1. Physical Photo

FEATURES

- Power Supply Voltage Range: 4.5V* ~ 16V
 - High Efficiency: ≥94% (LDA=3.3V@4A&VPS=8V)
 - Maximum Output Current: 4A
 - Output Current Noise: <100µA@0.1Hz ~ 10Hz
 - Output Ripple Voltage: <10mV@500KHz
 - High Stability: ±8mA@4A for entire temp. range
 - Fully Shielded
 - Both DIP and SMT Packages Available
 - Compact Size
 - 100 % Lead (Pb)-free and RoHS Compliant
- *To utilize the internal reference voltage source, the minimum power supply must be > 5.8V.

APPLICATIONS

Driving laser diodes, DPSSL, EDFA, fiber laser, direct diode laser, etc., with low noise and high efficiency.

Table 1 Pin Function Descriptions

Pin #	Name	Type	Description
1	SDN	Digital Input	Shut down control. Negative logic, >1.4V = enable, <0.95V = shut down, normal threshold voltage = 1.2V.
2	SYNC	Synchronization Input	The default internal switching frequency is 500KHz. This pin can be connected to an external clock signal of which the frequency can be about 10% to 15% higher than the switching frequency. In this way, the driver will be switching at the same frequency with the external clock signal, eliminating beating interferences. If other switching frequency is needed, please tell us, it can be specified from 300KHz to 700KHz.
3, 7	GND	Signal Ground	Signal ground pin. Connect ADC and DAC grounds to here. When using a POT (potentiometer) to set the output current, connect the ground terminal of the POT to here.
4	5VR	Analog Output	Reference voltage. It can source 3mA max, with 5µVp-p noise between 0.1 to 10 Hz and 25ppm/°C stability max.

DESCRIPTION

This laser driver, ATLS4A212, is an electronic module designed for driving diode lasers by up to 4A constant current with high efficiency, low noise, high reliability, zero EMI, and small package. Figure 1 shows physical photo of the ATLS4A212.

It provides these functions: laser current control, laser current monitoring, over temperature protection, loop good indication, laser diode status indication, soft start, and shut down.

It comes with a high stability low noise 5V voltage reference output which can be used for setting the output current and, at the same time, for the ADCs (Analog to Digital Converters) and/or DACs (Digital to Analog Converters) as the reference voltage.

Warning: Both the surface mount and the through hole types of modules can only be soldered manually on the board by a solder iron of < 310°C (590°F), not go through a reflow oven process.

The ATLS4A212 is packaged in a 6 sided metal enclosure, which blocks EMIs (Electro-Magnetic Interferences) to prevent the driver and other electronics from interfering each other.

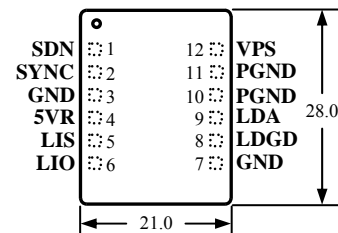

Figure 2. Pin Names and Locations

Figure 2 is the actual sized top view of the ATLS4A212, which also shows the pin names and locations. Its thickness is 5.7mm. The pin functions are described in Table 1 below.



5	LIS	Analog Input	Laser current setting voltage. There is an input resistor of 10M tied to GND. Setting it from 0V to 5V will set the laser current from 0A to 4A linearly.
6	LIO	Analog Output	Laser current output indication. 0V to 5V indicates the laser current being from 0A to 4A linearly.
8	LDGD	Digital Output	Laser diode good indication. When this pin is high, >2V, the control loop is working properly. When this pin is low, <0.3V, the laser diode is bad, or there is a short or open circuit at the laser diode.
9	LDA	Analog Output	Laser diode anode. Connect it to the anode of the laser diode.
10	PGND	Power Ground	Power ground pin. Connect this pin directly to the cathode of the laser diode.
11	PGND	Power Ground	Power ground pin. Connect this pin directly to power supply return path line.
12	VPS	Power Input	Power supply voltage. The driver works from VPS = 4.5V to 16V.

SPECIFICATIONS

Table 2 Characteristics ($T_{\text{ambient}} = 25^{\circ}\text{C}$)

Parameter	Value	Unit
Laser driver efficiency when $I_{\text{out}} = 4\text{A}$, $V_{\text{out}} = 3.3\text{V}$, & $VPS = 8\text{V}$.	≥ 94	%
Maximum output current	4	A
Low frequency, 0.1Hz to 10Hz, output current noise	<100	μA
Stability @ 4A	± 0.2	%
Laser current control signal at LIS	0 ~ 5	V
LIS control accuracy	± 0.2	%
Laser current indication signal at LIO	0 ~ 5	V
LIO indication accuracy	± 0.2	%
Reference output voltage	5	V
Output voltage range at LDA	0 ~ $0.98 \times VPS$	V
Power supply voltage range	4.5 ~ 16	V
Maximum power supply voltage	17	V
Start-up time	4	ms
Typical pull-down current at LDGD	6	mA
Operating case temperature	-40 ~ 85	$^{\circ}\text{C}$

OPERATION PRINCIPLE

The block diagram of the driver is shown in Figure 3. The shut down control circuit accepts signals from 3 sources: external shut down, over current and over temperature signals. When any of these signals is activated, the driver is shut down. Only when none all these 3 signals is activated, a soft start circuit starts enabling the driver stage.

The soft start circuit increases the output current slowly at the start up time and shuts down the current quickly. Thermal shutdown circuit turns the driver off if the junction temperature exceeds 175°C typically. The device reinitiates

the power up sequence when the junction temperature drops below 165°C typically. The driver is released from shutdown automatically when the junction temperature decreases to 10°C below the thermal shutdown trip point, and starts up under control of the soft start circuit. The over current protection circuit turns the driver off if the output current exceeds 10A @ $VPS=8\text{V}$ or 12A @ $VPS=16\text{V}$.

The high stability low noise 5V voltage reference is provided for setting the output current by setting the voltage of LIS, and can also be used for the ADCs and/or DACs.



The laser diode status indication circuit monitors laser diode status. When LDGD pin is high, >2V, the control loop is working properly; when this pin goes low, <0.3V, the laser diode is bad, or there is a short or open circuit at the laser diode.

The current measurement circuit monitors the output current and shuts down the driver upon detecting the output current exceeds the pre-set value. It also provides a signal, LIO, indicating the actual laser diode current. The relationship is:

Laser current = 0.8 × LIO voltage (A).

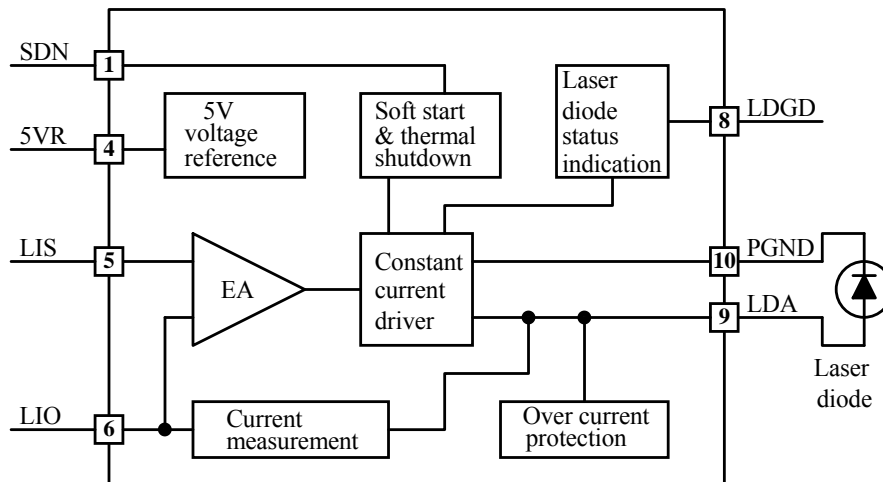

Figure 3. Block Diagram

APPLICATION INFORMATION

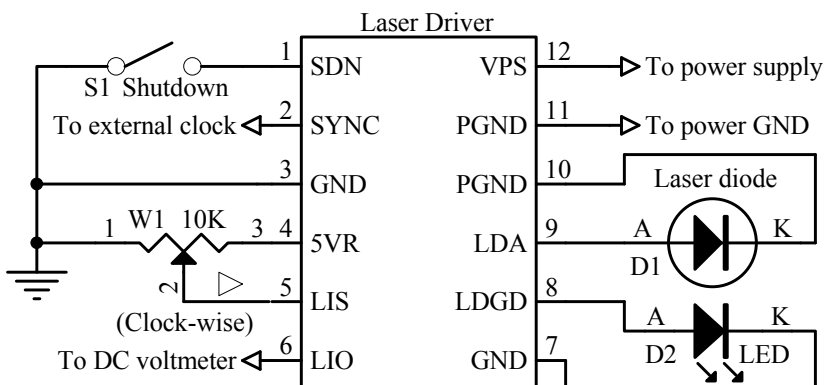

Figure 4. A Typical Stand-alone Application Schematic

Figure 4 shows a typical stand-alone application circuit.

In Figure 4, S1 is an externally shut down switch, it turns the driver off and on by tying SDN pin to the ground or releasing it respectively. The starting up time delay is about 4mS and the shut down time is about 20µS.

The switch S1 can also be an electronic switch, such as an I/O pin of a micro-driver, with an either open drain or push/pull output. See Figure 5. The internal equivalent circuit is a resistor of 100K pulling up this pin to VPS rail. When this pin voltage is >1.4V, the driver is enabled; <0.95V, the driver is shut down. Normal threshold voltage = 1.2V.

If not using a switch (S1) to control the laser, leave the SDN pin unconnected.

In Figure 4, the LED D1 is used to indicate laser diode status. When LDGD pin is high, >2V, the laser diode control loop is working properly. When LDGD pin is low, <0.3V, the laser diode is bad, or there is a short or open circuit at the laser diode. The LDGD pin can also be connected to a digital input pin of a micro-driver, when software/firmware is utilized in the system. See Figure 5. The equivalent circuit of this pin is a 5K resistor pulling up it to the VPS rail and an open drain FET pulling it down to the ground. The pull-up current can be increased by connecting an external pull-up resistor between VPS and LDGD pins. That is equivalent to paralleling the external resistor with the internal 5K pull-up resistor. However, the total pull-up resistor should be ≥1.5K @ VPS=5V or ≥1K @ VPS=3.3V. Otherwise, the internal open drain FET cannot provide the resistors with enough pull-down current to achieve a low enough potential level for a logic low indication. To calculate the total pull-up resistor, use the equation below:



$$R_{total} = (R_{internal} \times R_{external}) / (R_{internal} + R_{external})$$

where:

R_{total} is the total pull-up resistor,

$R_{internal}$ is the internal pull-up resistor,

$R_{external}$ is the external pull-up resistor.

The laser diode D2 is connected between LDA and PGND. It is worth mentioning that the power supply return terminal should be connected to the pin 11 PGND and the cathode of the laser diode should be connected to the pin 10 PGND. These 2 pins, 10 and 11, should not be connected together externally and they are connected together internally already by the driver.

Figure 5 shows a typical micro-processor-based application circuit.

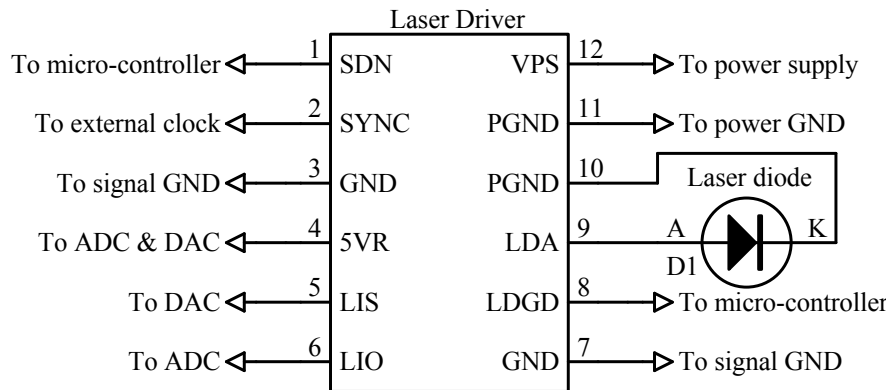

Figure 5. A Typical Micro-processor-based Application Schematic

Turning the Driver On and Off

The driver can be turned on and off by setting the SDN pin high and low respectively. It is recommended to turn the driver on by this sequence:

To turn on: turn on the power by providing the power supply voltage to the driver on VPS pin, turn on the driver by releasing the SDN pin.

To turn off: turn off the driver by lowering the voltage of SDN pin, turn off the power by stopping the voltage supply on the VPS pin.

When not controlling by the SDN pin: leave it unconnected and turn on and off the driver by the power supply.

Adjusting the Output Current

The output current is set by adjusting W1, which sets input voltages of LIS, pin 5. See Figure 4. The output current will be:

$$I_{output} = 0.8 \times V_{LIS} \text{ (A)}$$

LIS can also be set by using a DAC to replace the W1 in Figure 4. Make sure that the DAC has low output noise.

A RC low pass filtered can be inserted between the W1 output or the DAC output and the LIS pin, for lowering the output noise.

Monitoring the Output Current

The output current of the driver can be monitored by measuring the voltage on the LIO pin. This feature is very useful for micro-driver based system where the ADC is available and monitoring the current in real time is required.

This pin provides a very low noise voltage signal and is proportional to the output current:

$$I_{output} = 0.8 \times V_{LIO} \text{ (A)}$$

For example, when the output signal is 5V, the output current is 4A.

LIO can be used to drive an ADC directly, and also be measured by a multi-meter.

Driver Power Consumption

The power consumption of the driver can be calculated by:

$$P_{driver} = I_{input} \times VPS - I_{output} \times V_{LDA}$$

where P_{driver} is the power consumed by the driver itself; I_{output} is the output current;

I_{input} is the power supply's input current;

VPS is the power supply voltage;

V_{LDA} is the voltage across the laser diode;

$$\eta = (I_{output} \times V_{LDA}) / (I_{input} \times VPS)$$

When P_{driver} of ATLS4A212 exceeds 2.5W, a heat sink is needed to keep the driver's temperature below certain level, preferably below 85°C. For most applications, the power consumption exceeds 2.5W when the driving is outputting 4A, thus, heat sinking mechanism is needed. The best way for arranging the heat sinking for the driver is as follows: transferring the heat by sandwiching a piece of gap filler material between the top metal surface of ATLS4A212 and the internal metal surface of the final product's case as shown in Figure 6 below.

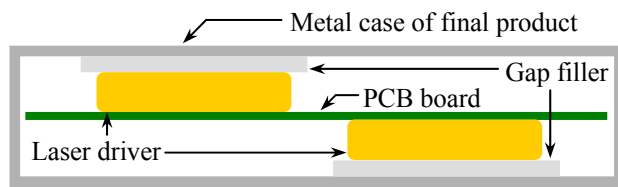

Figure 6. Transferring heat by the gap filler

The gap filler material needs to be mechanically elastic and thermally conductive. One of such products is the T-flex 200 filler sheet made by Lairdtech, the available thickness is between 1mm to 4mm. More detail technical data about this material can be found here:

www.lairdtech.com.

To reduce the power consumed by the driver, we recommend using a power supply with its voltage barely higher than $1.2 \times V_{laser_diode_max}$, where $V_{laser_diode_max}$ is the maximum possible laser diode voltage.

For example, for most diode lasers at 4A, the maximum forward voltage across the laser is about 6.3V, thus, using an 8V power supply is enough. Using an 8V power supply will result in less power consumption by the driver than using a 15V power supply.

The following draw shows the relationship between the load current and the efficiency.

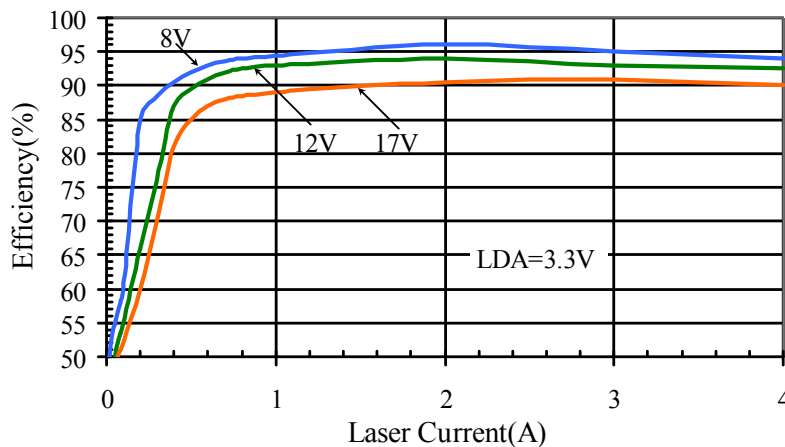

Figure 7. Efficiency vs. Laser Current

First Time Power Up

Laser diode is a high value and vulnerable device. Faults in connections and damages done to the driver during soldering process may damage the laser diode permanently.

To protect the laser diode, it is highly recommend to use 3 to 18 regular diodes which is >4A to form a “dummy laser” and insert it in the place of the real laser diode, when powering up the driver for the first time. Use an oscilloscope to monitor the LDA voltage at times of powering up and enabling the shutdown pin, and powering down the laser driver and turning off the shutdown pin, and make sure that there is not over-shoot in output voltage at the LDA pin. At the same time, it uses an ammeter in serious with the dummy laser, to make sure that the output current is correct.

After thoroughly checking and making sure of free of faults in the system, disconnect the dummy laser diode and connect the real laser diode in place.

The driver output voltage range for the laser is between 0 to $0.98 \times VPS$.

OUTLINE DIMENSIONS

The driver comes in 2 packages: through hole mount and surface mount. The former is often called DIP (Dual Inline Package) or D (short for DIP) package, the latter is called

SMT Surface Mount Technology) package. The part number for the former: ATLS4A212D, for the latter: ATLS4A212S.

Dimensions of the DIP package driver are shown in Figure 8. Dimensions of the SMT package driver are shown in Figure 9.

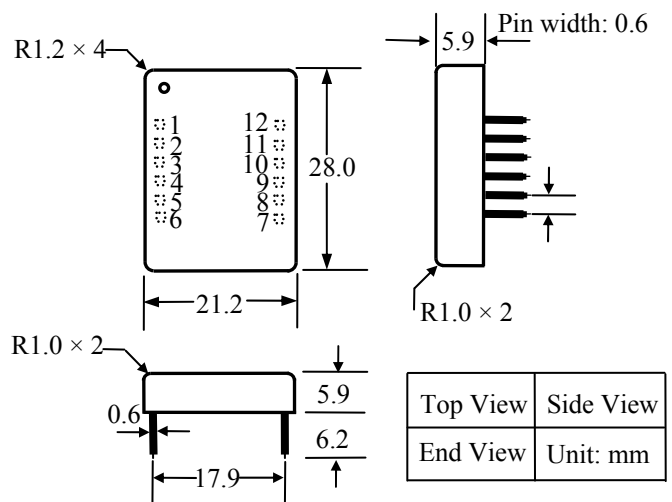

Figure 8. Dimensions of the DIP Package Driver

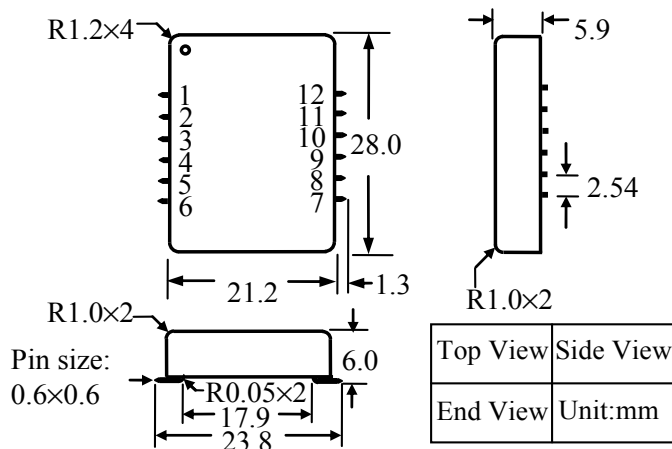

Figure 9. Dimensions of the SMT Package Driver

Figure 10 shows the foot-print which is seen from the end side of the PCB.

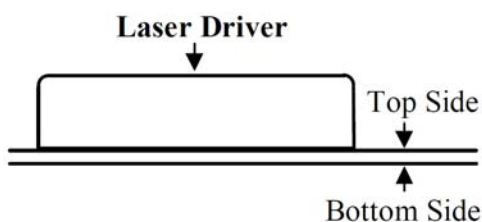

Figure 10. End View of the PCB Foot-print

Figure 11 shows the foot-print which is seen from the top side of the PCB, therefore, it is a vertical view.

“Tent” (i.e. cover the entire via by the solder mask layer) all the vias under the driver, otherwise, the vias can be shorted by the bottom plate of the driver which is internally connected the ground.

See Figures 11 and 12, it is recommended to use large copper fills for VPS, PGND, and the LDA pins, and other pins if possible, to decrease the thermal resistance between the module and the supporting PCB, to lower the module temperature.

ORDERING INFORMATION

Table 3 Part Number

Part Number	Description
ATLS4A212D	4A constant current driver in DIP package

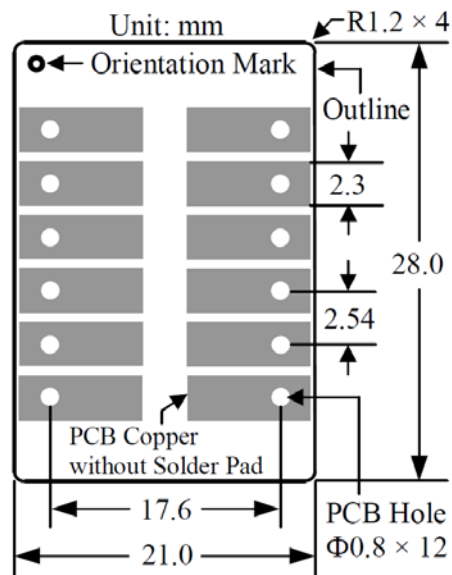

Figure 11. Top View of the Top Side PCB Foot-print

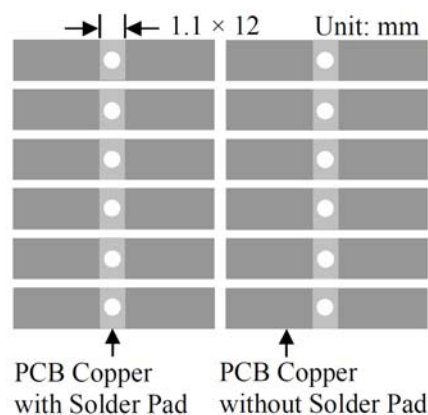

Figure 12. Top View of the Bottom Side PCB Foot-print

Figure 12 shows the foot-print which is seen from the bottom side of the PCB.

The SMT package dimension and PCB pattern details are given in separate document. Please contact us for getting this document.

MOUNTING

It is highly recommended to lower solder iron temperature to 310°C and solder the driver manually, so that the internal contents of the driver would not be affected.

After the soldering, it is also safe to check the laser driver’s functionality by using the “dummy laser” before connecting a real laser diode as mentioned previously on page 4.



ATLS4A212S	4A constant current driver in surface mount package
------------	---

Table 4 Unit Price

Quantity (pcs)	1 – 9	10 – 49	50 – 199	200 – 499	≥500
Unit Price	\$72.0	\$68.4	\$64.8	\$61.2	\$57.6

NOTICE

- ATI warrants performance of its products for one year to the specifications applicable at the time of sale, except for those being damaged by excessive abuse. Products found not meeting the specifications within one year from the date of sale can be exchanged free of charge.
- ATI reserves the right to make changes to its products or to discontinue any product or service without notice, and advise customers to obtain the latest version of relevant information to verify, before placing orders, that information being relied on is current and complete.
- All products are sold subject to the terms and conditions of sale supplied at the time of order acknowledgment, including those pertaining to warranty, patent infringement, and limitation of liability. Testing and other quality control techniques are utilized to the extent ATI deems necessary to support this warranty. Specific testing of all parameters of each device is not necessarily performed, except those mandated by government requirements.
- Customers are responsible for their applications using ATI components. In order to minimize risks associated with the customers’ applications, adequate design and operating safeguards must be provided by the customers to minimize inherent or procedural hazards. ATI assumes no liability for applications assistance or customer product design.
- ATI does not warrant or represent that any license, either express or implied, is granted under any patent right, copyright, mask work right, or other intellectual property right of ATI covering or relating to any combination, machine, or process in which such products or services might be or are used. ATI’s publication of information regarding any third party’s products or services does not constitute ATI’s approval, warranty or endorsement thereof.
- IP (Intellectual Property) Ownership: ATI retains the ownership of full rights for special technologies and/or techniques embedded in its products, the designs for mechanics, optics, plus all modifications, improvements, and inventions made by ATI for its products and/or projects.
- If not utilizing the internal reference voltage source, the minimum power supply can be as low as 4.5V.