

FEATURES

- Ultra Low Noise: $<10\mu A_{P-P}$ @0.1Hz to 10Hz
- High Current without Heat Sink: 1A
- High Absolute Accuracy: $<0.1\%$
- High Stability: 100ppm/°C
- Dual Modulation Ports: High/Low Speed
- Low Drop Out Voltage: 1V
- Complete Shielding
- Compact Size
- 100 % lead (Pb)-free and RoHS compliant
- SMT Package Available

APPLICATIONS

Driving diode lasers with low noise, including DPSSLs, EDFAs, fiber lasers, diode laser modules, etc.

DESCRIPTION

The ATLS1A102 is an electronic module designed for driving diode lasers with up to 1A low noise current. The output voltage is 1.5V to 4V when powered by a 5V power supply.

The ATLS1A102 has two input ports for modulating the output current: one for low speed of up to 0.08Hz bandwidth and the other high speed modulation of up to 300KHz. The former is for CW (Continuous Wave) operation and the latter is for modulated operation.

A high stability low noise 2.5V reference voltage is provided internally for setting the output current. This reference can also be as the voltage reference for external ADCs (Analog to Digital Converters) and DACs (Digital to Analog Converters), which might be used for monitoring and/or setting the laser current.

The shut down pin can turn the controller electronically without disconnecting the power supply.

There is an output port, LIO (pin 11), dedicated for monitoring the laser current. It can be connected to an ADC or a voltmeter.

The control loop is monitored in real time by an internal circuit, to make sure that it works properly. The monitoring result is sent to the LPGD node (pin 12). When this pin is pulled up internally, it indicates that the loops works fine.

By default, the maximum output current is set to 1A. This value can be altered by external circuit which is shown in the application section.

The ATLS1A102 is packaged in a 6 sided metal enclosure, which blocks EMIs (Electro-Magnetic Interferences) to prevent the controller and other electronics from interfering each other.

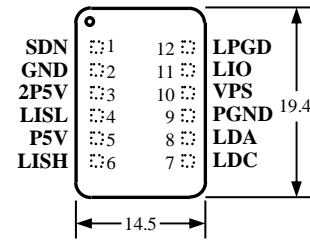

Figure 1. Pin Names and Locations

The controller has 2 types of mounting packages: through hole and surface mount. The latter saves PCB space the controller takes. Figure 1 is the actual size top view of the ATLS1A102D, which shows the pin names and locations. Its thickness is 5mm.

SPECIFICATIONS

Parameter	Value	Unit/Note
Maximum output current	1	A
Output current noise (0.1Hz to 10Hz)	<10	μA_{P-P}
Low speed current set voltage (on LISL pin)	0~2.5	V
High speed current set voltage (on LISL pin)	0~2.5	V
Low speed modulation cut-off frequency	0.08	Hz
High speed modulation cut-off frequency	300	kHz
Power supply voltage range	4.5~5.5	V
Thermal resistance	60 (free air) 30 (PCB mount)	°C/W
Operating case temperature	-25~85	°C
Rise times of small signal	1.5	μS
Fall times of small signal	1	μS
Rise times of large signal	1.5	μS
Fall times of large signal	1	μS

OPERATION PRINCIPLE

Figure 2 is the block diagram of the controller.

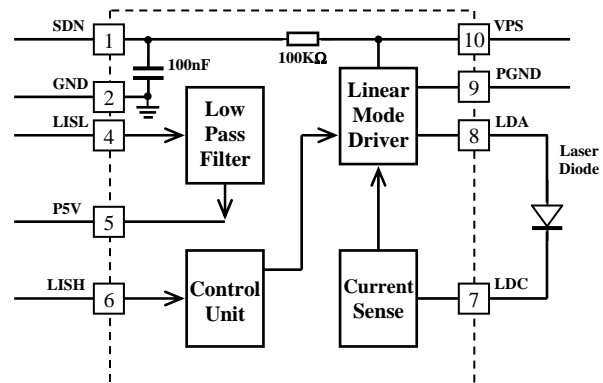

Figure 2. Block Diagram

APPLICATIONS

Figure 3 shows a stand-alone application circuit.

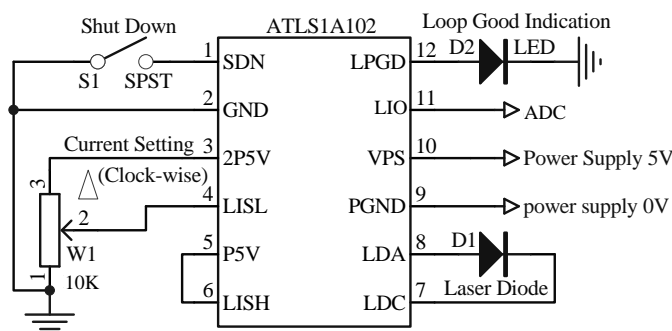

Figure 3. A Typical Stand-alone Application Schematic

Output Noise

Since the controller uses a switch mode driver, there will be some ripple noise at the switching frequency, 1MHz. The voltage magnitude is about 30mV at this frequency.

For applications which cannot tolerate this noise, users can choosing the same controller with the switch mode driver disabled. The part number becomes ADLS1A102-D-L or ADLS1A102-S-L.

The disadvantage to turn off the switch mode driver is that the efficiency of the controller will be lowered, thus, the controller's temperature may rise to too high a value. The power consumption of the controller will be calculated in this way:

$$P_{\text{controller}} = I_{\text{OUT}} \times (VPS - V_{\text{laser_diode}}),$$

where I_{OUT} is the output current;

VPS is the power supply voltage;

$V_{\text{laser_diode}}$ is the voltage across the laser diode.

If the $P_{\text{controller}}$ is $>2W$, heat sink might be needed.

When prefer not to use the heat sink, this is option: lowering the controller power consumption by reducing the power supply voltage VPS. Please make sure:

$$VPS \geq V_{\text{laser_diode_max}} + 1.2V,$$

where $V_{\text{laser_diode_max}}$ is the maximum possible laser diode voltage.

Turning the Controller On and Off

The controller can be turned on and off by setting the SDN pin high and lower respectively. It is recommended to turn the controller on by this sequence:

To turn on: turn on the power by providing the power supply voltage to the controller, turn on the controller by releasing the SDN pin.

To turn off: turn off the controller by lowering the voltage of SDN pin, turn off the power by stopping the voltage supply on the VPS pin.

When not controlling by the SDN pin: leave it unconnected and turn on and off the controller by the power supply.

In Figure 3, S1 is the shut down switch. The internal equivalent input circuit of SDN pin is a pull-up resistor of 100K being connected to VPS. If not using a switch (S1) to control the laser, leave the SDN pin unconnected. D1 is the laser diode, which is float from the ground and the VPS, with its anode connected to the LDA, pin 8, and cathode connected to the LDC, pin 7. D2 is an LED, indicating when the control loop works properly, that is: the output current equals to the input set value. This pin has an internal pull up resistor of 5K to the power supply pin, VPS, pin 10. The pull down resistance is 200Ω. When higher pull up current is needed for such as driving an LED, an external resistor can be placed between the VPS and the LPGD pins. Make sure that the resistor is not too small that the pull down resistor will not be able to pull the pin low enough when the controller loop is not good. When choosing not to use an LED for indicating the working status, leave the LPGD pin unconnected.

Setting the Output Current

The LPGD pin can also be connected to a digital input pin of a micro-controller, when software/firmware is utilized in the system.

The output current is set by adjusting W1, which sets input voltages of LISL, pin 4. The output current will be:

$$I_{\text{OUT}} = LISL(V)/2.5V (A).$$

LISL should never be left float. Otherwise, the output current will go too high a value that the laser might be damaged.

The LISL pin allows modulating the output current at a speed of up to 0.08Hz. This low speed port filters out high frequency noise, if any, in the input signal applied to this pin.

In addition to using the LPGD pin for monitoring the working status of the controller, the output current can be monitored directly by measuring the voltage of LIS pin when LPGD (loop good) pin is high. The equation is:

$$I_{\text{OUT}} = LIS (V)/2.5V (A)$$

For example, when seeing $LIS = 2.5V$, the output current is $2.5V/2.5V = 1A$.

Figure 4 shows an application where ATLS1A102 is interfaced with a micro-controller.

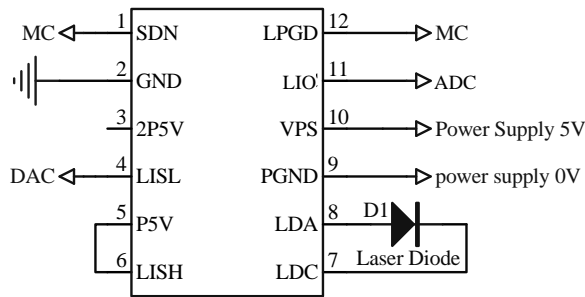

Figure 4. A Typical Micro-processor-based Application

In this circuit, the input current can be set by a DAC (Digital to Analog Converter). By sensing the logic level of LPGD, pin 12, the working status of the controller can be monitored by a micro-controller (MC), when it is logic “1”, the loop is good; “0”, the loop is at fault, which includes open circuit at the laser diode connections, or short circuit from LDA to ground, but excludes short circuit at the laser diode and short circuit from LDC to ground. Shut down pin can also be controlled by the micro-controller, setting it to logic “1” turns on the controller, “0” turns it off. Please notice that this pin comes with an internal pull up resistor of 100K, it can be ORed (logic OR) by multiple digital ports of several micro-controllers, with each of the port having an open-drain output. The internal voltage reference output, 2P5V, pin 3, can be used as the reference voltage for the ADCs and the DACs.

The output current is set by adjusting W1, which sets input voltages of LISL (Laser I (current) Set Low-speed), pin 4. The output current will be:

$$I_{OUT} = LISL(V)/2.5V (A).$$

LISL should never be left float. Otherwise, the output current will go too high a value that the laser might be damaged.

The LISL pin allows modulating the output current at a speed of up to 0.08Hz. This low speed port filters out high frequency noise, if any, in the input signal applied to this pin.

In addition to using the LPGD pin for monitoring the working status of the controller, the output current can be monitored directly by measuring the voltage of LIS pin. The equation is:

$$I_{OUT} = LIS (V)/2.5V (A).$$

For example, when seeing LIS = 2.5V, the output current is 2.5V/2.5V = 1A.

MODULATING OUTPUT CURRENT

When low speed current modulation is needed, connect LISL pin to the modulation signal. As LISL changes from 0 to 2.5V, the output current changes from 0 to 1A linearly. The rise and fall time achieved by modulating LISL is about

4 seconds and the equivalent bandwidth is about 0.1Hz. The advantage of using LISL as the modulation signal input port is that the output current noise will not increase. The disadvantage is that the speed is not high.

The LISL pin can be set by a POT, DAC, or a PWM signal directly from a micro-controller. Please notice that when using a PWM signal for setting the current voltage LISL, a low pass filter will not be needed, since there is an internal low pass filter.

It is recommended not to set the LISL pin to 0V, but keep it >0.05V at all the time. The reason is that the laser diode usually has a junction voltage of 2.5V, when setting the LISL pin voltage to 0V, the output voltage will warble between 0V and 2.5V, cause some oscillation slightly.

When high speed current modulation is needed, feed the modulation signal to LISH (no need to connect LISH to P5V pin). As LISH change from 0 to 0.5V, the output current changes from 0 to 1A linearly. The fall and rise time is about 1μS, and the full power bandwidth is about 300KHz. Using LISH pin as the modulation signal input port results in high speed modulation, however, the noise from the modulation signal source will be converted into output current noise.

The switch can be any analog switch, but having low leakage current.

OUTPUT CURRENT MONITORING

The output current can be monitored in real time by measuring the voltage on the LIS pin. When LPGD (loop good) pin is high,

$$I_{OUT} = LIS (V)/2.5V (A).$$

For example, when seeing the LIS pin has a voltage of 2.5V, the output current = 2.5V/2.5V = 1A.

Use a high input impedance voltage meter or DAC to monitor the output current, such as >5K. Otherwise, some error will be introduced at the output current. When the impedance is 5K, the current error caused at the output is about 0.01%.

Please be aware that adding capacitor on this pin will increase the high frequency noise current. Therefore, when monitoring the output current on this pin continuously, insert a resistor of about >5K in series with the voltage meter or ADC. In this way, there is no big capacitance added on the LDC pin.

Under no-fault operation conditions, the output voltage of LDC is always the same as that of LISH.

POWER UP PROCEDURE

Laser diode is a vulnerable device. Special cautions must be taken for turning on the controller. These are the recommendations:

1. Hold the SDN pin to ground by a mechanical switch or an electronic logic device when turning on the power on the VPS pin and release the SDN pin to logic high after the

VPS voltage is stabilized to turn on the laser.

- If choose not to control the SDN pin for turning on the laser, leave the SDN pin unconnected. There is an internal capacitor holding SDN pin to logic low. Now, the laser can be turned on and off by using the VPS pin.

Controller Power Consumption

The power consumption of the controller can be calculated by:

$$P_{\text{controller}} = I_{\text{OUT}} \times (V_{\text{PS}} - V_{\text{LDA}}),$$

where I_{OUT} is the output current;

V_{PS} is the power supply voltage;

V_{LDA} is the voltage across the laser diode.

When the P_controller exceeds 1W, a heat sink might be needed. The best way for arranging the heat sinking for the driver is as follows: transferring the heat by sandwiching a piece of thermal conductive pad between the top metal surface of the laser driver and the internal metal surface of the final product as shown in Figure 5.1 and 5.2 below. The recommended thickness of the thermal conductive pad in Figure 5.1 is 1~4mm, and in Figure 5.2 is 0.5mm. ATI also provides a series of thermal conductive pads, click [here](#) for more information.

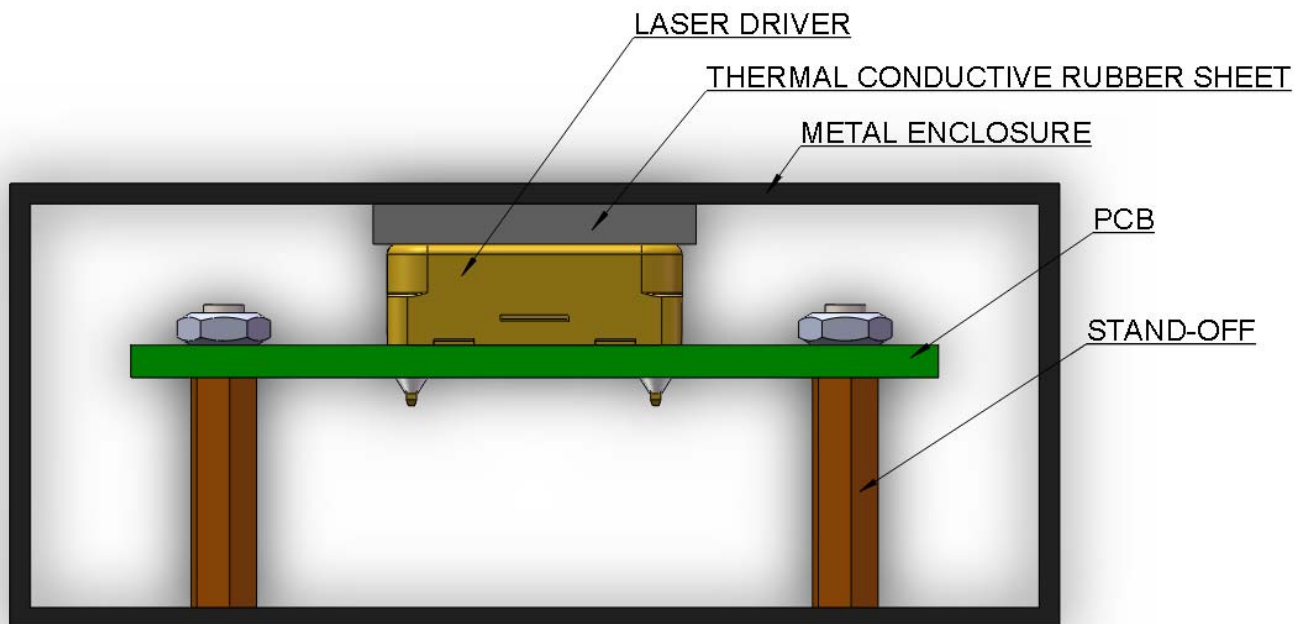

Figure 5.1 Transferring Heat with Metal Enclosure

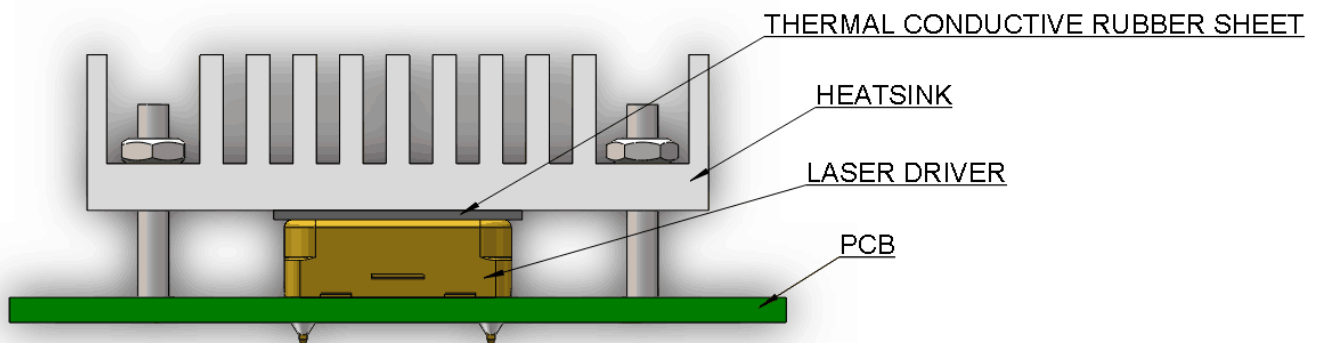

Figure 5.2 Transferring Heat with Heat Sink

FIRST TIME POWER UP

Laser is a high value and vulnerable device. Faults in connections and damages done to the controller during soldering process may damage the laser permanently.

To protect the laser, it is highly recommend to use 3 regular diodes of >1A to form a “dummy laser” and insert it in the place of the real laser diode, when powering up the controller for the first time. Use an oscilloscope to monitor the LDA voltage at times of power-up and power-down, make sure that there is not over-shoot in voltage. At the same time, use an ammeter in series with the dummy laser, to make sure that the output current is correct.

After thorough checking free of faults, disconnect the dummy laser and connect the real laser in place.

The controller output voltage range for the laser is between 0.5 to 4V when powered by a 5V power supply.

MECHANICAL DIMENSIONS AND MOUNTING

The ATLS1A102 comes in 2 packages: through hole mount and surface mount. The former is often called DIP (Dual In-line package) or D (short for DIP) package and has a part number: ATLS1A102–D, and the latter is often called SMT (Surface Mount Technology) or SMD (Surface Mount Device) package and has a part number: ATLS1A102–S.

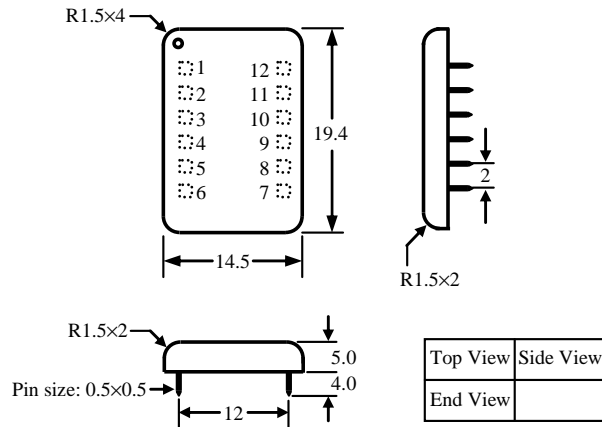

Figure 6. Dimensions of the DIP Package Controller

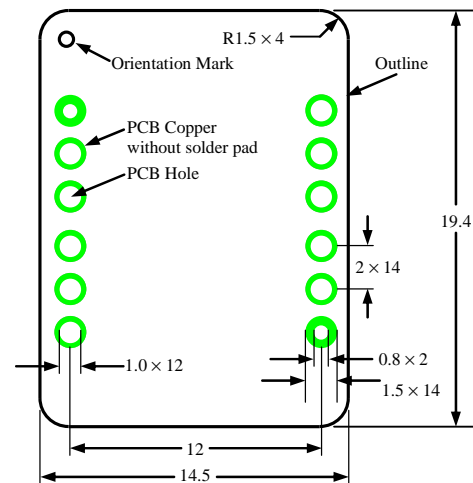

Figure 7. Top Side PCB Foot-print for the DIP Package

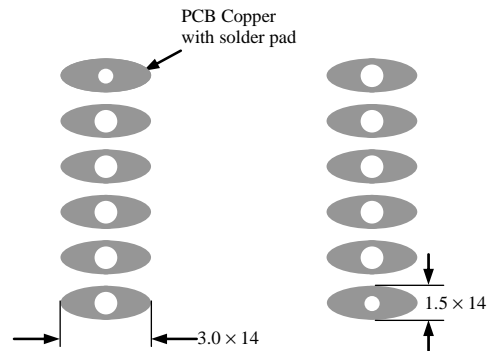

Figure 8. Top View of the Bottom Side PCB Foot-print

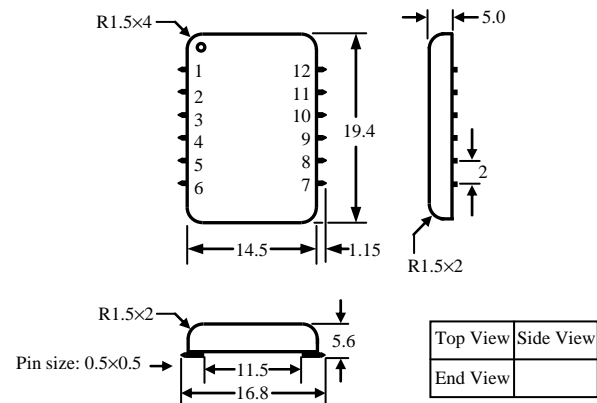

Figure 9. Dimensions of the SMT Package Controller

Figure 10 shows the foot print which is seen from the top side of the PCB, therefore, it is a “see through” view.

Please notice that, in the recommended foot print for the DIP package, the holes for pin 2 to 6, and 8 to 12 have larger holes than needed for the pins. This arrangement will make it easier for removing the controller from the PCB, in case there is a rework needed. The two smaller holes, for pin 1 and 7, will hold the controller in the right position.



NOTE: We don't recommend this for new design.

ORDERING INFORMATION

Part #	Description
ATLS1A102-D	Controller in DIP package
ATLS1A102-S*	Controller in SMT package*

Warning: The through hole modules can only be soldered manually on the board by a solder iron of < 310°C (590°F), not go through a reflow oven process.

NOTE: The power supply may have overshoot, when happens, it may exceed the maximum allowed input voltage, 6V, of the controller and damage the controller permanently. To avoid this from happening, do the following:

1. Connect the controller solid well with the power supply before turning on the power.
2. Make sure that the power supply has sufficient output current. It is suggested that the power supply can supply 1.2 to 1.5 times the maximum current the controller requires.
3. When using a bench top power supply, set the current limit to >1.5 times higher than the maximum current the controller requires.

PRICES

Quantity	1 – 9	10 – 49	50 – 199	200 – 499	≥500
ATLS1A102-D ATLS1A102-S	\$75	\$71.3	\$67.5	\$63.8	\$60.0

NOTICE

1. ATI warrants performance of its products for one year to the specifications applicable at the time of sale, except for those being damaged by excessive abuse. Products found not meeting the specifications within one year from the date of sale can be exchanged free of charge.
2. ATI reserves the right to make changes to its products or to discontinue any product or service without notice, and advise customers to obtain the latest version of relevant information to verify, before placing orders, that information being relied on is current and complete.
3. All products are sold subject to the terms and conditions of sale supplied at the time of order acknowledgment, including those pertaining to warranty, patent infringement, and limitation of liability. Testing and other quality control techniques are utilized to the extent ATI deems necessary to support this warranty. Specific testing of all parameters of each device is not necessarily performed, except those mandated by government requirements.
4. Customers are responsible for their applications using ATI components. In order to minimize risks associated with the customers' applications, adequate design and operating safeguards must be provided by the customers to minimize inherent or procedural hazards. ATI assumes no liability for applications assistance or customer product design.
5. ATI does not warrant or represent that any license, either express or implied, is granted under any patent right, copyright, mask work right, or other intellectual property right of ATI covering or relating to any combination, machine, or process in which such products or services might be or are used. ATI's publication of information regarding any third party's products or services does not constitute ATI's approval, warranty or endorsement thereof.
6. IP (Intellectual Property) Ownership: ATI retains the ownership of full rights for special technologies and/or techniques embedded in its products, the designs for mechanics, optics, plus all modifications, improvements, and inventions made by ATI for its products and/or projects.