

Figure 1.1. Physical Photo of the ATH10K1R25

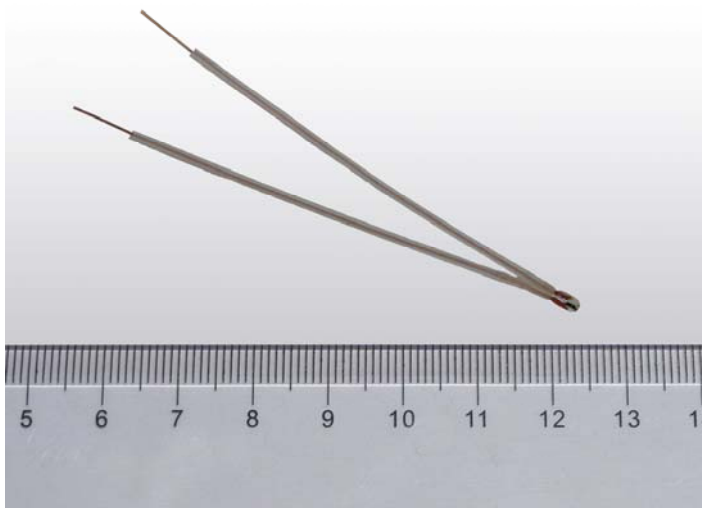

Figure 1.2. Physical Photo of the ATH10K1R25T70

DESCRIPTIONS

The ATH10K1R25 series thermistor is consisted of three versions, ATH10K1R25 as shown in Figure 1.1, ATH10K1R25T70 shown in Figure 1.2 and ATH10K1R25T70S. The ATH10K1R25 has bear leads coated with copper, the ATH10K1R25T70S has the leads covered by high temperature Teflon tubing and sealed by epoxy, while the ATH10K1R25T70 is the non-sealed version.

The ATH10K1R25 is of a high stability and high precision glass encapsulated thermistor. Comparing with conventional epoxy encapsulated thermistors, ATH10K1R25 features much wider temperature range, especially on the high end, much better long term stability, smaller size, and shorter response time. In addition, there are two insulation versions available, one of which comes with leads covered by Teflon tubing, the ATH10K1R25T70, and the other one, the ATH10K1R25T70S, is sealed between the head and the tubing. They can work under up to 140°C temperature and the latter is of liquid resistant.

The ATH10K1R25 series thermistors can be used to sense the temperatures for laser diodes, optical components, industrial process control, etc., where high temperature sensitivity, long term stability, and/or high sensing temperature are required.

Figure 2, Figure 3 and Figure 4 show the mechanical dimensions of the ATH10K1R25, the ATH10K1R25T70 and the ATH10K1R25T70S respectively. All dimension units are millimeters.

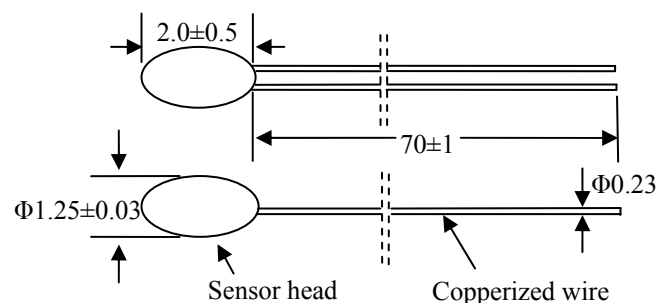

Figure 2. Side View of ATH10K1R25

MAIN FEATURES

- Glass Encapsulated for Long Term Stability & Reliability
- High Resistance Accuracy: 1%
- Small Size: $\phi 1.25\text{mm} \times 2.0\text{mm}$
- Wide Temp. Range: -40°C to 270°C
- 100 % Lead (Pb)-free and RoHS Compliant

APPLICATION AREAS

Temperature sensing for laser diodes, optical components, industrial process control, etc., where high temperature sensitivity, long term stability, and/or high sensing temperature are required.

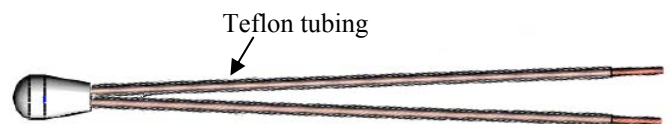

Figure 3. Side View of ATH10K1R25T70



Figure 4. Side View of ATH10K1R25T70S

SPECIFICATIONS

| Reference Data | |
|--------------------------|-------------------------|
| Parameter | Value |
| Nominal Resistance@ 25°C | 10K ± 1% |
| β Value @ 25°C/50°C | 3950K ± 1% |
| β Value @ 25°C/85°C | 3990K ± 1% |
| R@25°C / R@50°C | 2.771 |
| R@25°C / R@85°C | 9.271 |
| Thermistor Diameter | 1.25 ± 0.03mm |
| Thermistor Length | 2.0 ± 0.5mm |
| Lead Diameter | 0.23mm |
| Lead Length | 70 ± 1mm |
| Dissipation Factor | ≥ 1.0mW/°C |
| Insulation Resistance | 50MΩ |
| Thermal Time Constant | 6 Second (in still air) |

APPLICATIONS

The thermistor ATH10K1R25, ATH10K1R25T70 or ATH10K1R25T70S can be used to sense solid block temperature with high stability and accuracy. The best way to mount the thermistor is to drill a hole on the object for which the temperature needs to be measured and regulated, and use thermal conductive epoxy to pot the thermistor inside the hole. The diameter of the hole should be 1.4 to 1.8mm and the depth should 3 to 4mm. When a deeper hole is needed, drill a 2 stage hole to prevent epoxy bubbles trapped inside the deep hole which could cause temperature measurement errors. Figure 5 shows the section view of the 2 stage hole.

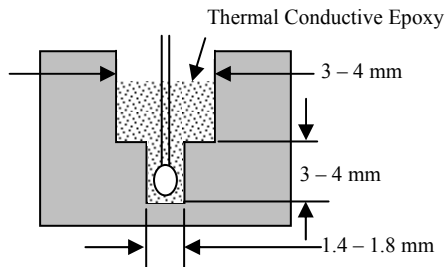

Figure 5. Section View of the 2 Stage Hole

The worst mounting result would be to have air bubbles trapped inside the thermistor mounting hole. These bubbles cause thermal sensing time delay and sensing temperature errors. To avoid the bubbles, in addition to drilling the 2 stage hole, use thin epoxy, vibrate the assembly before curing the epoxy, and cure the epoxy at high temperature, 80°C to 120°C, depending on the epoxy used and the maximum temperature the assembly components allow.

The thermistor lead wires are made of copperized alloy and there is no insulation coating on them. Therefore, when using

bare leaded thermistors, make sure that they do not touch each other after mounting the thermistor.

Some thermal conductive epoxies are also electrically conductive and such epoxies should not be used for mounting the thermistors, since the lead wires are conductive and the epoxy would change the thermistor's resistance, thus causing temperature sensing errors.

Notice: Bare leaded and the non-sealed versions cannot be used in water or other liquid directly, since the lead wires would be corroded.

CAUTIONS

1. Do not bend the thermistor leads at the location that is too close to the thermistors body, to avoid breaking the glass coating, as shown in Figure 6.1, Figure 6.2, and Figure 6.3 below. Only bend the leads at the location that is at least 2mm away from the thermistor body.

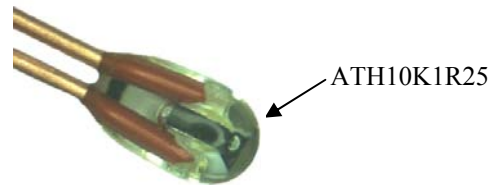

Figure 6.1. Bare Leaded Thermistor Head Photo

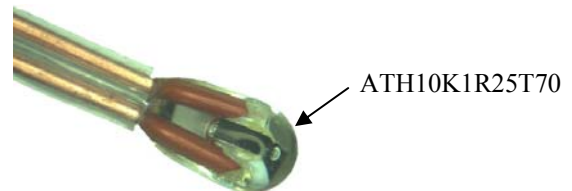

Figure 6.2. Tubing Leaded Non-sealed Thermistor Head Photo

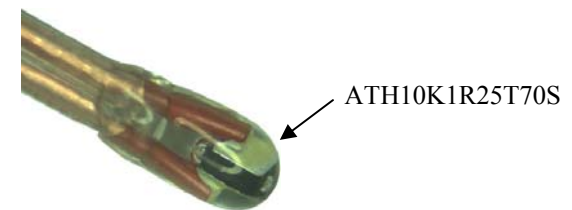

Figure 6.3. Tubing Leaded Sealed Thermistor Head Photo

2. Do not apply a large DC voltage across the thermistor in the temperature sensing circuit. The thermistor's self-heating temperature is about 1°C/mW. By injecting a 10μA current into the thermistor, it consumes 1mW and the self-heating temperature is about 1°C if the thermistor is placed in still air at a normal room temperature. Therefore, the injection current onto the thermistor needs to be much lower than 10μA when the thermistor is placed in the air for high accuracy air temperature sensing applications. Injecting short current pulses into the thermistor is one of the ways to reduce



the average current level on the thermistor in order to minimize the self-heating effect.

- Handle the thermistor with care, do not use metal tools to hold the thermistor body with excessive force, otherwise, the glass body may crack, affecting its accuracy and stability.

Thermistor Resistance

Beta Value (β)

A simple approximation for the relationship between the resistance and temperature for ATH10K1R25 is to use an exponential approximation. This approximation is based on simple curve fitting to experimental data and uses two points on a curve to determine the value of β . The equation relating resistance to temperature using β is:

$$R = Ae^{\frac{\beta}{T}}$$

Where:

- R = thermistor resistance at temp T,
- A = constant of equation,
- β = beta, the material constant,
- T = thermistor temperature in °K (Kelvin),

To calculate β for any given temperature range, the following formula applies:

$$\beta = \ln(R_{T1} / R_{T2}) / (1/T1 - 1/T2)$$

Where β is measured in K, R_{T1} is the resistance at T1, while R_{T2} is the resistance at T2.

β can be used to compare the relative steepness of ATH10K1R25 curves. However, the value of β will vary depending on the temperatures used for calculating the value. For example, to calculate β for the temperature range of 25°C to 50°C:

$$T1 = (25 + 273.15)^\circ K = 298.15^\circ K,$$

$$T2 = (50 + 273.15)^\circ K = 323.15^\circ K,$$

$$R_{T1} = 10K\Omega,$$

$$R_{T2} = 3.6085K\Omega;$$

This value of β would be referenced as $\beta_{25^\circ C/50^\circ C}$, and calculated as:

$$\beta_{25^\circ C/50^\circ C} = \ln(10/3.6085) / (1/298.15 - 1/323.15) = 3950K;$$

By using the same formula, $\beta_{25^\circ C/85^\circ C}$, will be:

$$\beta_{25^\circ C/85^\circ C} = \ln(10/1.0786) / (1/298.15 - 1/358.15) = 3990K.$$

When using the β value to compare 2 thermistors, make sure that the β values are calculated based on the same 2 temperature points.

Temperature Coefficient of Resistance (α)

Another way to characterize the R-T curve of the ATH10K1R25 is to use the slope of the resistance versus

temperature (R/T) curve at one temperature. By definition, the resistance slope vs. temperature is given by:

$$\alpha = (1/R) \times (dR/dT);$$

Where T is the temperature in °C or °K, R is the resistance at temperature T.

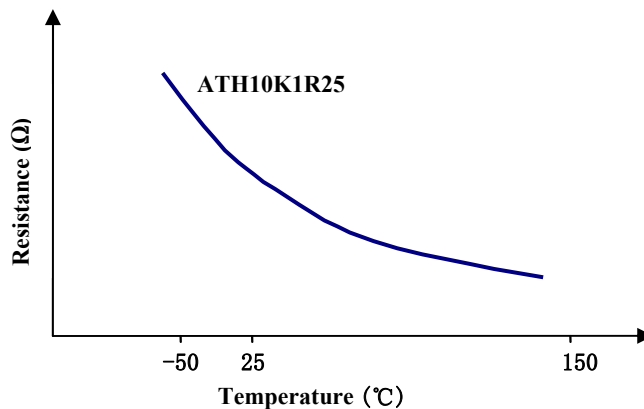

Figure 7. Resistance vs. Temperature for ATH10K1R25

As shown in Figure 7, the steepest position of the ATH10K1R25 curve is at colder temperatures.

The temperature coefficient is one method that can be used for comparing the relative steepness of the curves. It is highly recommended to compare the temperature coefficient at the same temperature because α varies widely over the operating temperature range.

Resistance Ratio (Slope)

The resistance ratio, or slope, for thermistors is defined as the ratio of the resistance at one temperature to the resistance at a higher temperature. As with resistance ratios, this method will vary depending on the temperatures used for calculating the value. This method can also be used to compare the relative steepness of two curves. There is no industry standard for the two temperatures that are used to calculate the ratio, we can select two common temperatures from the table below, for example, 25°C and 50°C, then the result of this calculation: $R@25^\circ C / R@50^\circ C$, will be:

$$R@25^\circ C / R@50^\circ C = 10/3.6085 = 2.771;$$

And this calculation: $R@25^\circ C / R@85^\circ C$, will be: $R@25^\circ C / R@85^\circ C = 10/1.0786 = 9.271$.



Steinhart-Hart Thermistor Equation

The Steinhart-Hart Equation is an empirically derived polynomial formula which does best in describing the relationship between the resistance and the temperature of ATH10K1R25, which is much more accurate than β method. To solve for temperature when resistance is known, yields the following equation:

$$1/T = a + b(\ln R) + C(\ln R)^3;$$

Where:

- T = temperature in °K (Kelvin),
- a, b and c are equation constants,
- R = resistance in Ω at temp T;

To solve for resistance when the temperature is known, the form of the equation is:

$$R = e^{\left[\left(-\frac{x}{2} + \left(\frac{x^2}{4} + \frac{\psi^3}{27} \right)^{\frac{1}{2}} \right)^{\frac{1}{3}} + \left(-\frac{x}{2} - \left(\frac{x^2}{4} + \frac{\psi^3}{27} \right)^{\frac{1}{2}} \right)^{\frac{1}{3}} \right]}$$

Where:

$$x = \frac{a - 1/T}{c}, \psi = \frac{b}{c}.$$

The a, b and c constants can be calculated for either a thermistor material or for individual values of the thermistors within a material type. To solve for the constants, three sets of data must be used. Normally, for a temperature range, the low end, middle end and high end values are used to calculate the constants, resulting in the best fit for the equation over the range. Using the Steinhart-Hart equation allows for accuracy as good as $\pm 0.001^\circ\text{C}$ over a 100°C temperature span.



Resistance Temperature Characteristics

| Temp. | Resistance | Temp. | Resistance | Temp. | Resistance | Temp. | Resistance | Temp. | Resistance |
|-------|------------|-------|------------|-------|------------|-------|------------|-------|------------|
| °C | KΩ | °C | KΩ | °C | KΩ | °C | KΩ | °C | KΩ |
| -40 | 342.55 | 7 | 23.041 | 54 | 3.1061 | 101 | 0.6639 | 148 | 0.1957 |
| -39 | 320.26 | 8 | 21.935 | 55 | 2.9940 | 102 | 0.6463 | 149 | 0.1912 |
| -38 | 299.57 | 9 | 20.908 | 56 | 2.8858 | 103 | 0.6280 | 150 | 0.1869 |
| -37 | 280.36 | 10 | 19.921 | 57 | 2.7816 | 104 | 0.6102 | 151 | 0.1786 |
| -36 | 262.51 | 11 | 18.984 | 58 | 2.6834 | 105 | 0.5932 | 152 | 0.1745 |
| -35 | 245.92 | 12 | 18.100 | 59 | 2.5871 | 106 | 0.5766 | 153 | 0.1706 |
| -34 | 230.49 | 13 | 17.264 | 60 | 2.4969 | 107 | 0.5605 | 154 | 0.1667 |
| -33 | 216.13 | 14 | 16.471 | 61 | 2.4086 | 108 | 0.5449 | 155 | 0.1629 |
| -32 | 202.77 | 15 | 15.717 | 62 | 2.3244 | 109 | 0.5229 | 156 | 0.1593 |
| -31 | 190.31 | 16 | 15.004 | 63 | 2.2441 | 110 | 0.5153 | 157 | 0.1557 |
| -30 | 178.71 | 17 | 14.327 | 64 | 2.1658 | 111 | 0.5013 | 158 | 0.1523 |
| -29 | 167.89 | 18 | 13.683 | 65 | 2.0915 | 112 | 0.4877 | 159 | 0.1489 |
| -28 | 157.80 | 19 | 13.073 | 66 | 2.0202 | 113 | 0.4745 | 160 | 0.1456 |
| -27 | 148.37 | 20 | 12.494 | 67 | 1.9515 | 114 | 0.4617 | 161 | 0.1424 |
| -26 | 139.58 | 21 | 11.943 | 68 | 1.8854 | 115 | 0.4493 | 162 | 0.1393 |
| -25 | 131.36 | 22 | 11.419 | 69 | 1.8219 | 116 | 0.4371 | 163 | 0.1363 |
| -24 | 123.68 | 23 | 10.923 | 70 | 1.7610 | 117 | 0.4256 | 164 | 0.1333 |
| -23 | 116.49 | 24 | 10.449 | 71 | 1.7022 | 118 | 0.4141 | 165 | 0.1304 |
| -22 | 109.78 | 25 | 10.000 | 72 | 1.6457 | 119 | 0.4032 | 166 | 0.1276 |
| -21 | 103.49 | 26 | 9.5730 | 73 | 1.5916 | 120 | 0.3927 | 167 | 0.1249 |
| -20 | 97.597 | 27 | 9.1658 | 74 | 1.5393 | 121 | 0.3823 | 168 | 0.1222 |
| -19 | 92.091 | 28 | 8.7783 | 75 | 1.4891 | 122 | 0.3724 | 169 | 0.1196 |
| -18 | 86.912 | 29 | 8.4085 | 76 | 1.4406 | 123 | 0.3628 | 170 | 0.1171 |
| -17 | 82.063 | 30 | 8.0586 | 77 | 1.3941 | 124 | 0.3535 | 171 | 0.1146 |
| -16 | 77.525 | 31 | 7.7224 | 78 | 1.3494 | 125 | 0.3445 | 172 | 0.1122 |
| -15 | 73.259 | 32 | 7.4041 | 79 | 1.3063 | 126 | 0.3356 | 173 | 0.1099 |
| -14 | 69.245 | 33 | 7.0995 | 80 | 1.2648 | 127 | 0.3271 | 174 | 0.1076 |
| -13 | 65.485 | 34 | 6.8109 | 81 | 1.2246 | 128 | 0.3189 | 175 | 0.1054 |
| -12 | 61.958 | 35 | 6.5341 | 82 | 1.1861 | 129 | 0.3109 | 176 | 0.1032 |
| -11 | 58.626 | 36 | 6.2711 | 83 | 1.1488 | 130 | 0.3031 | 177 | 0.1011 |
| -10 | 55.508 | 37 | 6.0180 | 84 | 1.1131 | 131 | 0.2955 | 178 | 0.0990 |
| -9 | 530.5 | 38 | 5.7788 | 85 | 1.0786 | 132 | 0.2882 | 179 | 0.0970 |
| -8 | 502.4 | 39 | 5.5496 | 86 | 1.0453 | 133 | 0.2811 | 180 | 0.0950 |
| -7 | 476.2 | 40 | 5.3302 | 87 | 1.0132 | 134 | 0.2742 | 181 | 0.0931 |
| -6 | 451.3 | 41 | 5.1207 | 88 | 0.9823 | 135 | 0.2675 | 182 | 0.0912 |
| -5 | 428.0 | 42 | 4.9211 | 89 | 0.9524 | 136 | 0.2609 | 183 | 0.0894 |
| -4 | 405.8 | 43 | 4.7315 | 90 | 0.9236 | 137 | 0.2546 | 184 | 0.0876 |
| -3 | 385.1 | 44 | 4.5478 | 91 | 0.8957 | 138 | 0.2484 | 185 | 0.0859 |
| -2 | 36.281 | 45 | 4.3740 | 92 | 0.8690 | 139 | 0.2425 | 186 | 0.0842 |
| -1 | 34.407 | 46 | 4.2082 | 93 | 0.8431 | 140 | 0.2367 | 187 | 0.0825 |
| 0 | 32.738 | 47 | 4.0484 | 94 | 0.8181 | 141 | 0.2311 | 188 | 0.0809 |
| 1 | 31.104 | 48 | 3.8944 | 95 | 0.7938 | 142 | 0.2256 | 189 | 0.0793 |
| 2 | 29.568 | 49 | 3.7485 | 96 | 0.7705 | 143 | 0.2203 | 190 | 0.0778 |
| 3 | 28.109 | 50 | 3.6085 | 97 | 0.7481 | 144 | 0.2151 | 191 | 0.0763 |
| 4 | 26.729 | 51 | 3.4764 | 98 | 0.7262 | 145 | 0.2100 | 192 | 0.0748 |
| 5 | 25.428 | 52 | 3.3464 | 99 | 0.7051 | 146 | 0.2052 | 193 | 0.0733 |
| 6 | 24.205 | 53 | 3.2243 | 100 | 0.6825 | 147 | 0.2004 | 194 | 0.0719 |



| Temp. | Resistance | Temp. | Resistance | Temp. | Resistance | Temp. | Resistance | Temp. | Resistance |
|-------|------------|-------|------------|-------|------------|-------|------------|-------|------------|
| °C | KΩ | °C | KΩ | °C | KΩ | °C | KΩ | °C | KΩ |
| 195 | 0.0706 | 211 | 0.0524 | 227 | 0.0396 | 243 | 0.0304 | 259 | 0.0237 |
| 196 | 0.0692 | 212 | 0.0514 | 228 | 0.0389 | 244 | 0.0299 | 260 | 0.0234 |
| 197 | 0.0679 | 213 | 0.0505 | 229 | 0.0382 | 245 | 0.0294 | 261 | 0.0230 |
| 198 | 0.0666 | 214 | 0.0496 | 230 | 0.0376 | 246 | 0.0290 | 262 | 0.0227 |
| 199 | 0.0654 | 215 | 0.0487 | 231 | 0.0370 | 247 | 0.0285 | 263 | 0.0223 |
| 200 | 0.0641 | 216 | 0.0479 | 232 | 0.0364 | 248 | 0.0280 | 264 | 0.0220 |
| 201 | 0.0630 | 217 | 0.0470 | 233 | 0.0358 | 249 | 0.0276 | 265 | 0.0217 |
| 202 | 0.0618 | 218 | 0.0462 | 234 | 0.0352 | 250 | 0.0272 | 266 | 0.0214 |
| 203 | 0.0606 | 219 | 0.0454 | 235 | 0.0346 | 251 | 0.0268 | 267 | 0.0210 |
| 204 | 0.0595 | 220 | 0.0446 | 236 | 0.0340 | 252 | 0.0264 | 268 | 0.0207 |
| 205 | 0.0584 | 221 | 0.0439 | 237 | 0.0335 | 253 | 0.0260 | 269 | 0.0204 |
| 206 | 0.0574 | 222 | 0.0431 | 238 | 0.0329 | 254 | 0.0256 | 270 | 0.0201 |
| 207 | 0.0563 | 223 | 0.0424 | 239 | 0.0324 | 255 | 0.0252 | | |
| 208 | 0.0553 | 224 | 0.0416 | 240 | 0.0319 | 256 | 0.0248 | | |
| 209 | 0.0543 | 225 | 0.0409 | 241 | 0.0314 | 257 | 0.0244 | | |
| 210 | 0.0533 | 226 | 0.0402 | 242 | 0.0309 | 258 | 0.0241 | | |



ORDERING INFORMATIONS

Table 1. Part Number of the Thermistor

| Part # | Description |
|----------------|---|
| ATH10K1R25 | High stability miniature thermistor with bare leads |
| ATH10K1R25T70 | High stability miniature thermistor with leads covered by Teflon tubing |
| ATH10K1R25T70S | High stability miniature thermistor with leads covered by Teflon tubing and sealed by epoxy |

Table 2. Unit Price of the Thermistor

| Part # | 1 – 9 | 10 – 49 | 50 – 199 | 200 – 499 | ≥500 |
|----------------|--------|---------|----------|-----------|--------|
| ATH10K1R25 | \$2.4 | \$2.1 | \$1.8 | \$1.5 | \$1.2 |
| ATH10K1R25T70 | \$2.52 | \$2.21 | \$1.89 | \$1.58 | \$1.26 |
| ATH10K1R25T70S | \$2.64 | \$2.31 | \$1.98 | \$1.65 | \$1.32 |

NOTICE

- ATI warrants performance of its products for one year to the specifications applicable at the time of sale, except for those being damaged by excessive abuse. Products found not meeting the specifications within one year from the date of sale can be exchanged free of charge.
- ATI reserves the right to make changes to its products or to discontinue any product or service without notice, and advise customers to obtain the latest version of relevant information to verify, before placing orders, that information being relied on is current and complete.
- All products are sold subject to the terms and conditions of sale supplied at the time of order acknowledgment, including those pertaining to warranty, patent infringement, and limitation of liability. Testing and other quality control techniques are utilized to the extent ATI deems necessary to support this warranty. Specific testing of all parameters of each device is not necessarily performed, except those mandated by government requirements.
- Customers are responsible for their applications using ATI components. In order to minimize risks associated with the customers' applications, adequate design and operating safeguards must be provided by the customers to minimize inherent or procedural hazards. ATI assumes no liability for applications assistance or customer product design.
- ATI does not warrant or represent that any license, either express or implied, is granted under any patent right, copyright, mask work right, or other intellectual property right of ATI covering or relating to any combination, machine, or process in which such products or services might be or are used. ATI's publication of information regarding any third party's products or services does not constitute ATI's approval, warranty or endorsement thereof.
- IP (Intellectual Property) Ownership: ATI retains the ownership of full rights for special technologies and/or techniques embedded in its products, the designs for mechanics, optics, plus all modifications, improvements, and inventions made by ATI for its products and/or projects.