

## Load Assembly for Laser Drivers



Figure 1. Physical Photo of ALLD10A14V

### MAIN FEATURES

- Emulate the Non-Linearity of Laser Diodes
- High Continuous Current Capability: up to 10A.
- Extremely High Pulse Current Capability: 180A
- High Reverse Voltage on Each Diode: 150V
- Variable Voltage Drop Steps: 0.8V, 1.6V, 2.4V, ...  
12.8V@10A, 25°C
- Constant Fan Speed at Wide Input Voltage: 4.5V to 16V
- Over Temperature Shutdown @ Diode Temperature > 90°C
- Low Noise High Airflow Fan with Thermistor & PWM Control

### INTRODUCTION

This load assembly, ALLD10A14V, is designed to emulate laser diodes for evaluating multiple series of laser drivers, including ATLSxA103D, ATLSxA104D, ATLSxA214D, ATLSxA216D, etc. These laser drivers can be used to drive one or multiple laser diodes with high efficiency and low noise for DPSSL, EDFA, or fiber laser applications. They accept wide range input voltage and their output voltage can be from 0V to almost the same as the input voltage. The size is very small, but can output high current, high voltage, thus high output power. In addition, these laser

drivers have low output noise (except that there is a 500kHz 4mV<sub>P-P</sub> ripple voltage at the output) and wide modulation bandwidth. This laser load assembly can be used with this ATLS216DEV1.0 evaluation board, or be used alone, as a dummy laser load, to emulate one or multiple laser diodes.

It is recommended to read this application note along with the laser driver datasheets.

The laser drivers can be evaluated by using real lasers. However, the real laser diodes are very vulnerable: the maximum current allowed is only about 1.5 to 2 times higher than their normal value, the reverse voltage allowed is only 2V to 4V. The dummy laser uses regular durable diodes, the maximum current allowed is up to 100A for a short time, the maximum reverse voltage is 150V for each diode. All these make the dummy laser almost unbreakable, so that even the users may make some mistakes when using the laser drivers for the first time, there won't be any costly damages, as opposed to using real laser diodes. After making sure that the laser driver works well, all the connections are made correctly and reliably, then connect the real laser diodes with the laser driver.

This laser load assembly has 4 portions:

1. A series of regular diodes with configuration switches. The switch allows inserting different number of diodes into the circuit so that under the same current, such as 10A, the voltage drop will vary from 0.8V to 12.8V. The diodes can be configured to insert into the circuit or be shorted out by the switches, S1, S2, S3 and S4. The voltage drop value of each switch represents is listed in Table 1.
2. Heat sink and fan are used to cool down the diodes temperature.
3. Fan control circuit. To keep the fan running at a consistent speed even as the input power supply voltage varies from 4.5V to 16V.
4. Over temperature detection and shutdown circuit. To measure the diodes temperature and disconnect them from

the laser driver upon detecting the temperature exceeds 90°C, thus the diodes will not be damaged by over temperature.

Table 1. The Voltage Drop Value vs. Different Load Current ( $T_A=25^\circ\text{C}$ )

S4	S3	S2	S1	V <sub>OUT</sub> @8A (V)	V <sub>OUT</sub> @10A (V)
1	1	1	1	0.75	0.8
1	1	1	0	1.5	1.6
1	1	0	1	2.25	2.4
1	1	0	0	3	3.2
1	0	1	1	3.75	4
1	0	1	0	4.5	4.8
1	0	0	1	5.25	5.6
1	0	0	0	6	6.4
0	1	1	1	6.75	7.2
0	1	1	0	7.5	8
0	1	0	1	8.25	8.8
0	1	0	0	9	9.6
0	0	1	1	9.75	10.4
0	0	1	0	10.5	11.2
0	0	0	1	11.25	12
0	0	0	0	12	12.8

### BOARD DESCRIPTION

The ATLS216DEV1.0 Evaluation Board is consisted of a complete application circuit for driving laser diodes. It can set and monitor the output current, has numerous connection pads and terminal connectors for making connections with external components and instruments. For details of the evaluation board, please read its datasheet.

The silkscreen layer of dummy load assembly is shown in Figure 2 with other top layers, including top silkscreen, top copper, top solder mask, and multilayer (vias). Figure 3 only shows the image of top silkscreen layer.

On the left edge of the PCB, there are 5 solder pads for connecting to VPS, PGND, LDA, LDC and GND ports from the evaluation board. The connections can be made

by soldering wires onto the pads or using cables with banana plugs. On the right edge of the PCB, there are 4 switches. It can short out or insert in the diodes. Switch S1 controls one diode, when in 0 position, the diode is inserted into the circuit, producing a 0.8V voltage drop as the load; on the 1 position, and it shorts out the diode. Switch S2 controls 2 diodes, on the 1 position (insert table). On the bottom edge of the PCB, there are 6 solder pads for measuring ISN, ISP, TMO, GND, GND, GND. ISP and ISN are used to measure the voltage of RS ( $R_S=20\text{m}\Omega$ ), and then you can know the current of load diodes. TMO is used to measure the voltage and convert to the temperature (Figure 11). On the right bottom edge, there are 2 LED and a switch. LED1 display 5.6V voltage, LED2 display fan is working correctly, the switch control U1 chip. On the top edge of the PCB, there are 2 pins for the fan and SCM.

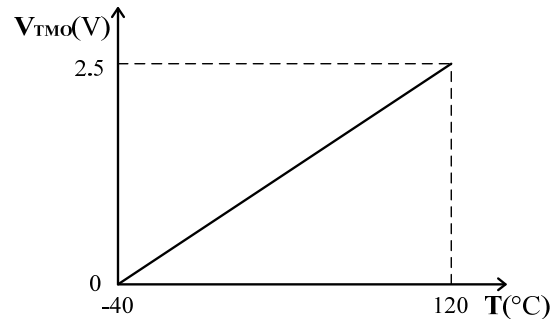

Figure 2. Temperature vs. Voltage Curve of TMO

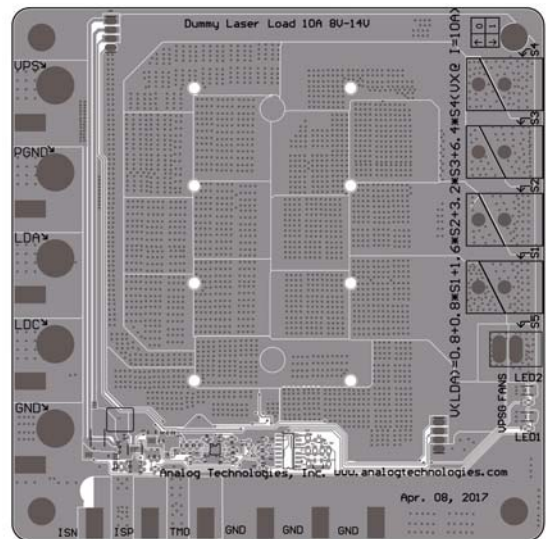

Figure 3. Top Silkscreen Layer with Other Top Layer

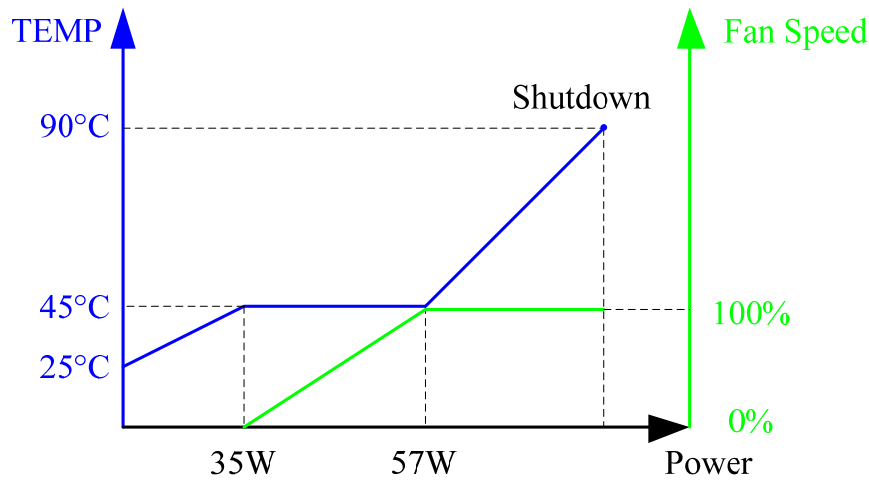

Figure 4. Temperature, Power and Fan Speed

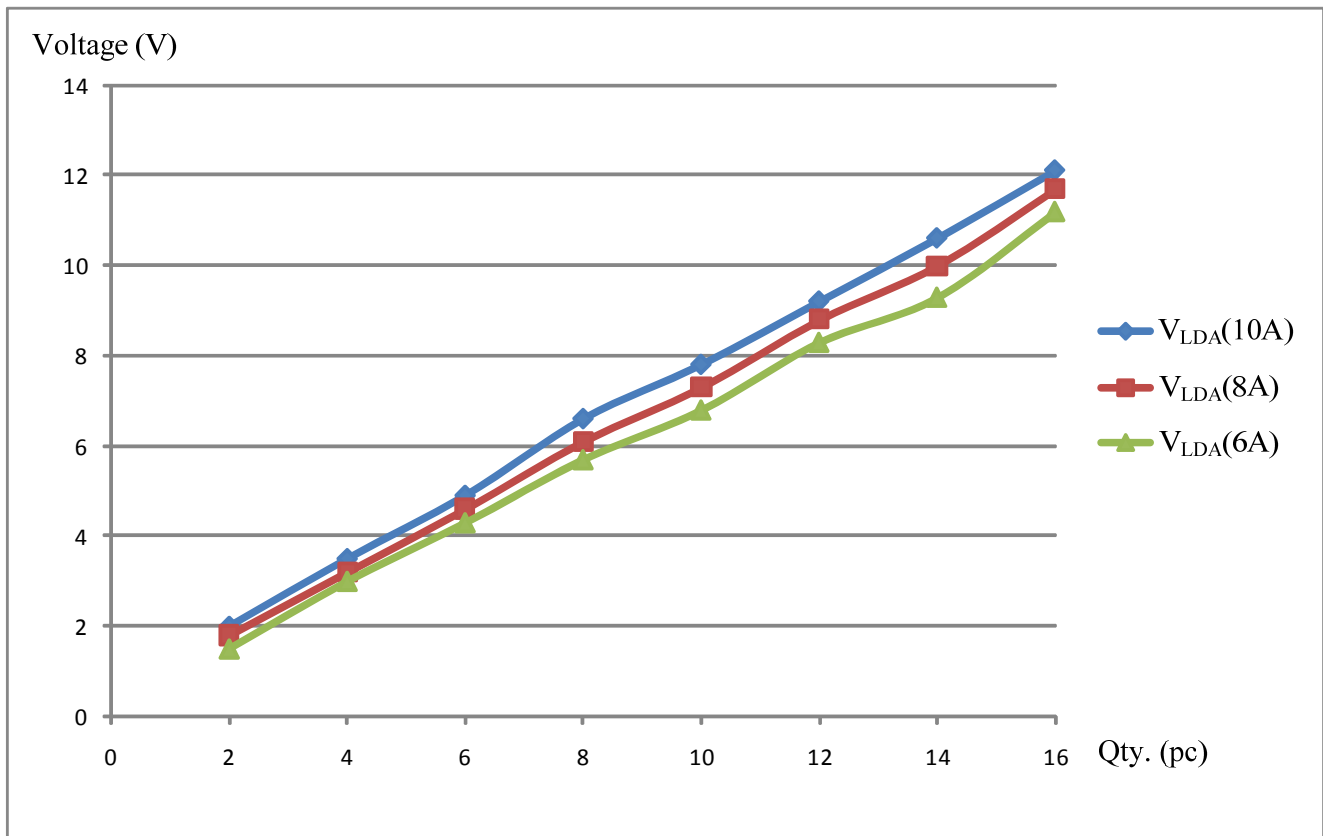

Figure 5. The Voltage of LDA vs. the Quantity of Laser Diodes@ T<sub>A</sub>=25°C

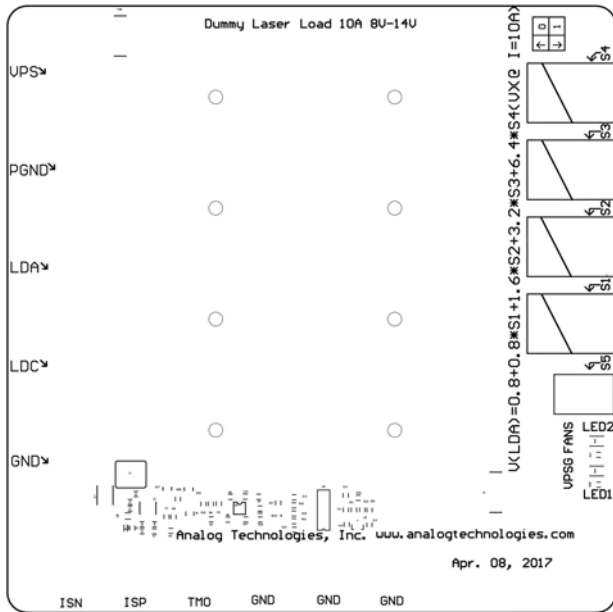

Figure 6. Top Silkscreen

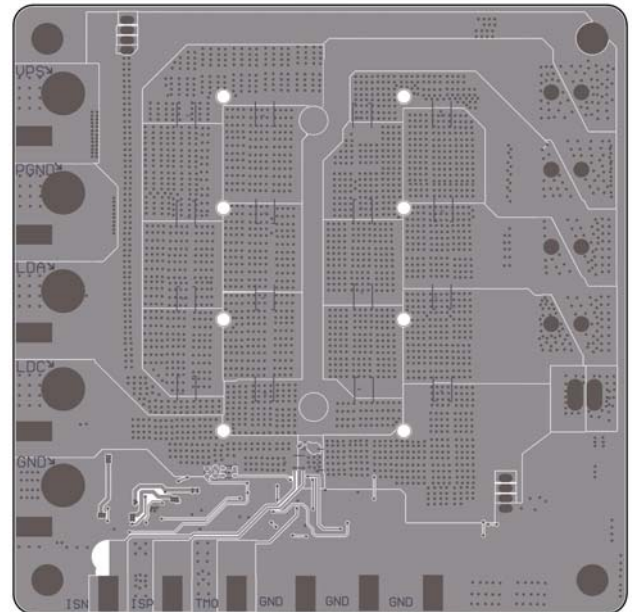

Figure 8. Bottom Layers

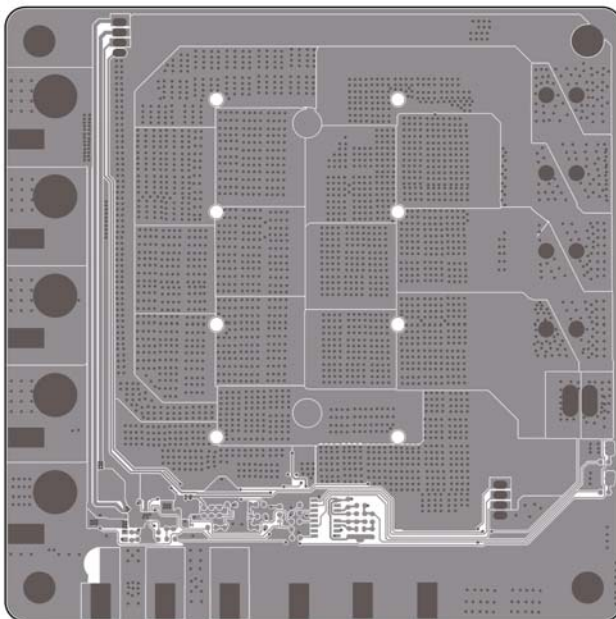

Figure 7. Top Layers without Top Screen Layer

Figure 7 shows all the top layers except the silkscreen layer.

Figure 8 below shows the bottom layers, including bottom

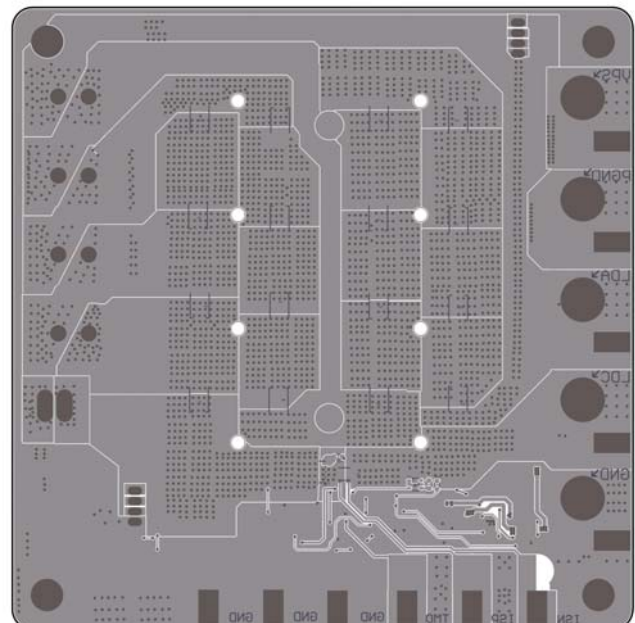

Figure 9. Mirrored Bottom Layers

copper, bottom solder mask, and multilayer (vias). Please notice that it is a “see through” image from the top side.

Figure 9 shows the mirrored bottom layers which is a directly-seen image from the bottom side.

The schematic is shown in Figure 12 below.

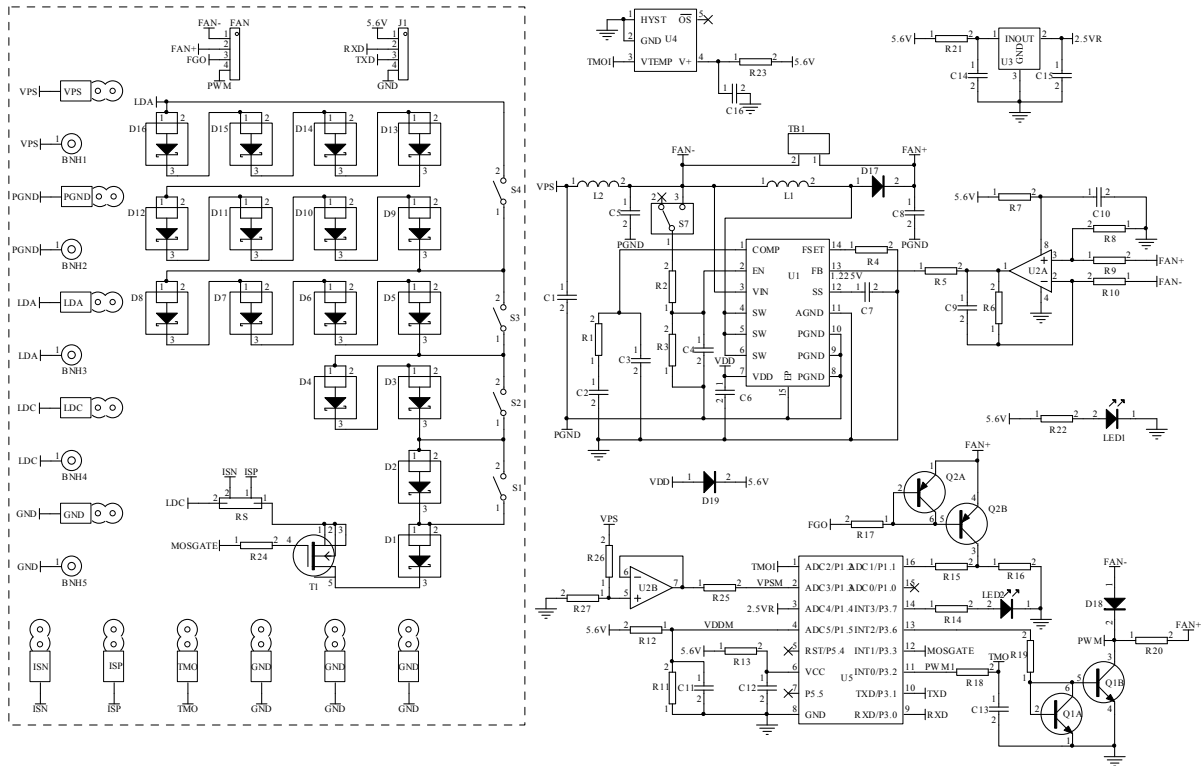

Figure 10. Schematic of ALLD10A14V

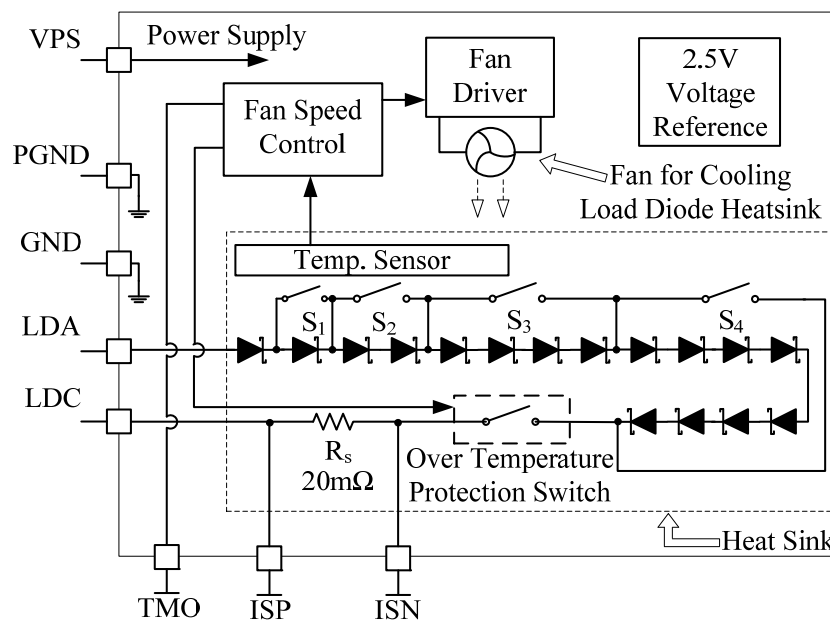

Figure 11. Internal Block Diagram of ALLD10A14V



GETTING STARTED

1. Hook up a power supply. It is needed for 2 purposes: turn on the electronic protection switch and power the cooling fan. There are 2 solder pads and 2 banana sockets for these 2 nodes respectively. The connection can be done by clipping, soldering onto the pads, or using banana cables. The power supply can be set to any value between 4.5V~16V. The higher the power supply voltage, the smaller the current drawn.
2. Use the switches S1 to S4 set the load voltage drop value to be similar to the actual laser diode voltage drop value, use Table 1 to look up for the switch position needed.
3. Connect the LDA and LDC output either from the evaluation board or from the laser driver to this load assembly board by the same way as described above, and turn on the laser driver by releasing the shutdown pin. Make sure that the power supply must be turned on before applying current/voltage between the LDA and LDC ports. This is because without the power supply be turned on, the diodes are not connected to the input ports, LDA and LDC.
4. **Warning: when injecting 4A current to the load at a high voltage drop value, such as >14V, the bottom heat sink may get very hot, don't touch them with your fingers.**
5. The switch bank and their corresponding diodes are shown in the table below. The total forward voltage range is from 0.8V to 12.8V. Please be aware of this fact: when the output voltage is low by shorting circuit all the diodes, the driver will consume more power and get too hot that the internal temperature protection circuit will shut off the driver automatically. When this happens, wait a few seconds, let the driver cool down, the driver will restart automatically after the temperature is lowered to certain level.

Switch Name	Corresponding Diode
S1	Diode D2
S2	Diode D3 and D4
S3	Diode D5, D6, D7 and D8
S4	Diode D9, D10, D11, D12, D13, D14, D15 and D16

6. Monitor the output voltage. This can be done by measuring the voltage between LDA and LDC ports with a volt meter. These 2 nodes can be approached at the left edge of the board. If the driver works well, the output current should remain the same as the output voltage changes with the temperature or changes with the change of the diode switch positions.
7. Connecting real laser diode(s) to the evaluation board. After making sure that the driver works properly and all the connections are made reliably, a real laser diode or a laser diode array can be connected to the evaluation board to replace this load assembly. This is the procedure:
  - A. Solder the laser diode terminal wires to the LDA and LDC solder pads of the evaluation board, make sure that the connections are made very reliably, no intermittent disconnection will occur.
  - B. Turn on the power to the evaluation board. At this time, the operator needs to be very careful in touching or moving the evaluation board set up. Any mistake in operating the board or any intermittent disconnections for connections on the board may result in damaging the laser diode(s) permanently.
  - C. If everything still works fine after step B above, the user can proceed to test the laser itself. The output current can be adjusted while the laser is turned on, but make sure that the output current will never exceed the laser's current limit.



- D. In case there are any suspicious or any problem occurs, turn off the shutdown switch to turn off the laser driver.
- E. **Warning: Many old benches top power supplies have high voltage spikes when power is up or power is down and these spikes may kill the laser driver. Thus, kill the laser diode(s). To avoid this from happening: use an oscilloscope to check the power supply before using it. If it**

**does have the spike, keep the power supply on and use an external mechanical switch to connect and disconnect the power supply output to the laser driver or laser driver evaluation board.**

Contact us at any time if you have any questions related to using our products, we always try best to help you. Thank you for reading and using our products.

**ORDERING INFORMATION**

Part #	Description	1 – 4pcs	5 – 9pcs	≥10pcs
ALLD10A14V	Laser Driver Load Assembly Rev. 1.0	\$159	\$155	\$149

**NOTICE**

1. ATI warrants performance of its products for one year to the specifications applicable at the time of sale, except for those being damaged by excessive abuse. Products found not meeting the specifications within one year from the date of sale can be exchanged free of charge.
2. ATI reserves the right to make changes to its products or to discontinue any product or service without notice, and advise customers to obtain the latest version of relevant information to verify, before placing orders, that information being relied on is current and complete.
3. All products are sold subject to the terms and conditions of sale supplied at the time of order acknowledgment, including those pertaining to warranty, patent infringement, and limitation of liability. Testing and other quality control techniques are utilized to the extent ATI deems necessary to support this warranty. Specific testing of all parameters of each device is not necessarily performed, except those mandated by government requirements.
4. Customers are responsible for their applications using ATI components. In order to minimize risks associated with the customers’ applications, adequate design and operating safeguards must be provided by the customers to minimize inherent or procedural hazards. ATI assumes no liability for applications assistance or customer product design.
5. ATI does not warrant or represent that any license, either express or implied, is granted under any patent right, copyright, mask work right, or other intellectual property right of ATI covering or relating to any combination, machine, or process in which such products or services might be or are used. ATI’s publication of information regarding any third party’s products or services does not constitute ATI’s approval, warranty or endorsement thereof.
6. IP (Intellectual Property) Ownership: ATI retains the ownership of full rights for special technologies and/or techniques embedded in its products, the designs for mechanics, optics, plus all modifications, improvements, and inventions made by ATI for its products and/or projects.