



High Efficiency AC input 70A 6V Laser Driver

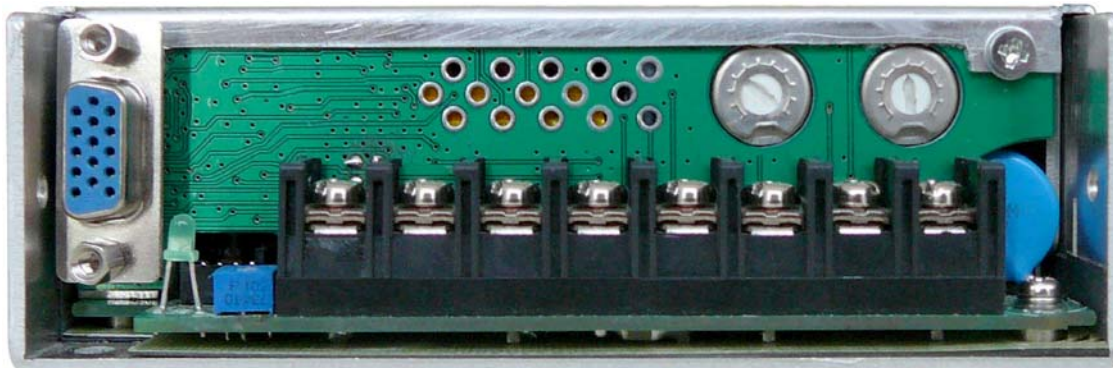

Figure 1. Front View of the AAS6V70A2

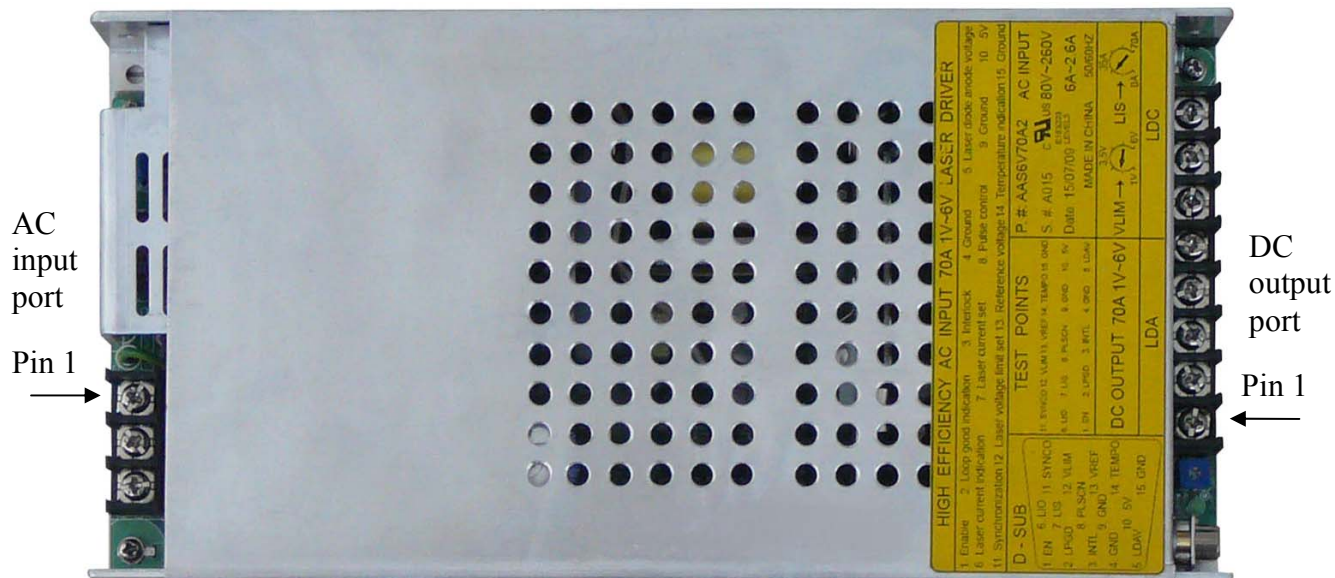

Figure 2. Top View of the AAS6V70A2

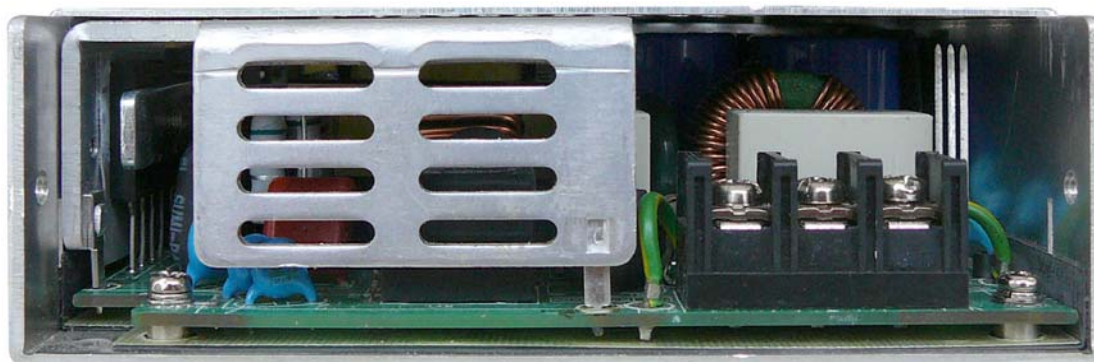

Figure 3. Rear View of the AAS6V70A2



#### FEATURES

- High Efficiency:  $\geq 89\%$
- Low Temperature Rise:  $35^\circ\text{C}$
- No Cooling Fan necessary
- Maximum Output Current: 70A
- Current Accuracy:  $\pm 1\%$
- Wide Input Voltage: 80VAC ~ 260VAC
- Wide Output Voltage: 3.5V ~ 6V (Drive two high current laser diodes)
- Configurable Output Current and Max. Output Voltage
- Short Circuit Protection
- Over-voltage Protection
- Over-temperature Protection
- Operating Temperature\*:  $-10^\circ\text{C} \sim 65^\circ\text{C}$
- Low Cost

\* After the chassis temperature exceeds certain level, the maximum allowable output power will be degraded linearly. Details are given in the application section.

#### APPLICATIONS

Drive high current laser diodes with low noise, high stability and high efficiency. Applications include fiber lasers, diode laser bars, etc.

#### DESCRIPTION

The AAS6V70A2 is an electronic module designed for driving laser diodes with up to 70A low noise current. An analog voltage of zero to 2.5V, or a potentiometer can set the output current, to between zero and 70A.

A high stability low noise 2.5V reference voltage is provided internally for setting the output current and maximum output voltage. This reference can also be used as the voltage reference for external ADCs (Analog to Digital Converters) and DACs (Digital to Analog Converters), which might be used for monitoring and/or setting the output current and maximum output voltage, the so-called

#### SPECIFICATIONS

Table 1 Characteristics ( $T_A = 25^\circ\text{C}$ )

Parameter	Symbol	Test Condition	Min.	Typ.	Max.	Unit
Efficiency	$\eta$	$V_{in} = 110\text{VAC}, V_{out} = 6\text{V}, I_{out} = 70\text{A}$	-	89	-	%
Output Current	$I_{out}$		0	Adjustable	70	A
Current Accuracy	$\Delta_I$	$-10^\circ\text{C} \sim 65^\circ\text{C}$	-	$\pm 1$	-	%
Input Voltage	$V_{in}$		90	110 or 220	264	VAC
Input Frequency	$f$		47	50	63	Hz
Output Voltage	$V_{out}$		1.3	Adjustable	6	V

compliance voltage.

The VLIM of the laser driver ranges from 0V to 2.5V, and the corresponding LDA output ranges from 1.3V to 6V. In order to avoid the effect that the overshoot given to the laser diode, this power supply shouldn't drive only one laser diode, but two. If drive only one laser diode, the laser diode must be able to afford at least 3.3V 40ms overshoot.

This laser driver module is highly efficient. Its efficiency is  $\geq 89\%$ . It saves energy and has low temperature rise. The module conducts its heat to its external chases which serves as both the heat-sink and heat conducting plate. Pressing the bottom surface of the chassis onto a large metal or granite table's surface will expand the equivalent heat sinking area of the module, thus reducing the temperature rise greatly. Using a cooling fan can lower the module's temperature, but not necessary. Using a cooling fan for this laser driver helps reducing its temperature rise, thus increasing the maximum output power capability, but the noise, air turbulence, and limited life time of the cooling fans make them unwanted in most application systems. Leaving the module in a free air environment is also OK, but the temperature rise will be higher, see the measured data in the next sections.

There is an over-temperature protection circuit, in case the module's temperature gets too high, the circuit will reduce the output current and the module will be working under constant temperature mode.

There is a soft-start and soft-cut circuit in the module, which gives smooth current transactions during power-up and power-down periods.

In case there is short-circuit at the output, the internal protection circuit will cut off the output.

The output voltage is automatically set from 3.5V to 6V while keeping the output current at a pre-set value.

The control loop is monitored in real time by an internal circuit, to make sure that it works properly. The monitoring result is sent to the LPGD node. When this pin is pulled up internally, it indicates that the loop works fine.



Operating Temperature	T <sub>A</sub>	-10	25	65	°C
-----------------------	----------------	-----	----	----	----

**MECHANICAL DIMENSIONS**

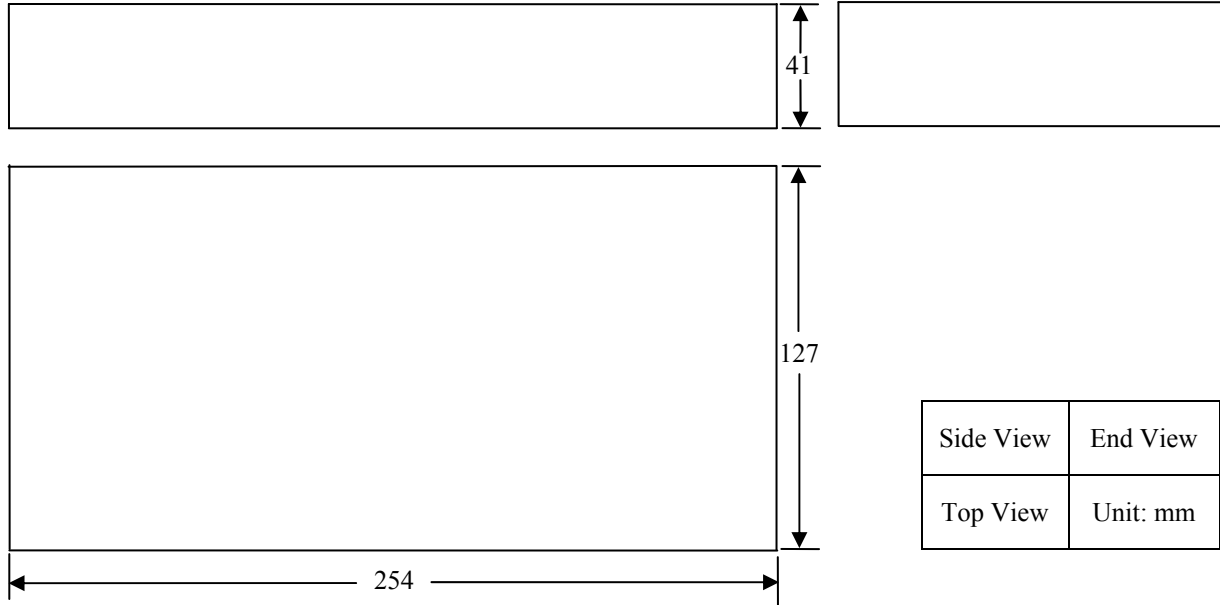

Figure 4. Dimensions of AAS6V70A2

**TERMINAL DESCRIPTIONS**

Table 2 Terminal Introduction

Pin #	Name	Meaning	Type	Description
<b>Front black terminal</b>	1, 2, 3, 4	LDA	Laser diode anode	Power output Connect it to the anode of the laser diode.
	5, 6, 7, 8	LDC	Laser diode cathode	Power output Connect it to the cathode of the laser diode.
<b>Rear black terminal</b>	1	ACL	Live wire	AC input Connect it to AC power supply.
	2	ACN	Neutral wire	AC input Connect it to AC power supply.
	3	ACG	AC ground	AC GND Connect it to AC ground.
<b>D-Sub</b>	1	EN	Enable	Digital input Internal 12K pull up resistor to 5V. Pulling this pin to GND will disable the driver.
	2	LPGD	Loop good indication	Digital output When this pin is high (4V, ≤5mA), the control loop is working properly, otherwise, not properly.
	3	INLC	Interlock	Digital input Connect to safety interlock switches. Open = off, connect to GND = run.
	4,15	GND	Ground	Ground Connect ADC and DAC grounds here.
	5	LDAV	Laser diode anode output voltage	Analog output =V <sub>out</sub> /3, V <sub>out</sub> is laser diode anode output voltage.
	6	LIO	Laser current indication output	Analog output An output voltage of 0 to 2.5V at this pin indicates the output current being 0 to 70A linearly.
7	LIS	Laser current set	Analog input 0V to 2.5V sets the output current from 0 to 70A linearly. This pin can be set by an external analog signal source, such as the output of a closed-looped op-amp, POT, or DAC. Input impedance is 10K.	



<b>D-Sub</b>	8	PLSCN	Pulse control	Digital input	TTL, 1 = on, 0 = off.
	9	CVMD	Current voltage mode indication	Digital output	When the laser driver is in current operation mode, the output of this pin is > 5V; in voltage operation mode, it's < 0.3V.
	10	5V	5V	Power output	5V 5mA.
	11	5V	Optional 5V or synchronization output	Power output	5V 5mA. Part number: AAS6V70A2.
		SYNCO		Digital output	This pin can be used as a clock signal for synchronizing other switch mode electronics, 100KHz. Part number: AAS6V70A2SN.
	12	VLIM	Setting laser voltage limit	Analog input	0V to 2.5V sets the laser output voltage from 1.3V to 6V linearly.
	13	2.5VR	Reference voltage	Analog output	2.5V reference voltage. To be used for setting the output current and the output voltage limit. It can also be used by external ADCs and DACs if they are used for monitoring and/or setting the output parameters.
14	TEMPO	Driver temperature indication output	Analog output	Operating internally temperature.	

**APPLICATION INFORMATION**

Figure 2 shows a typical application circuit.

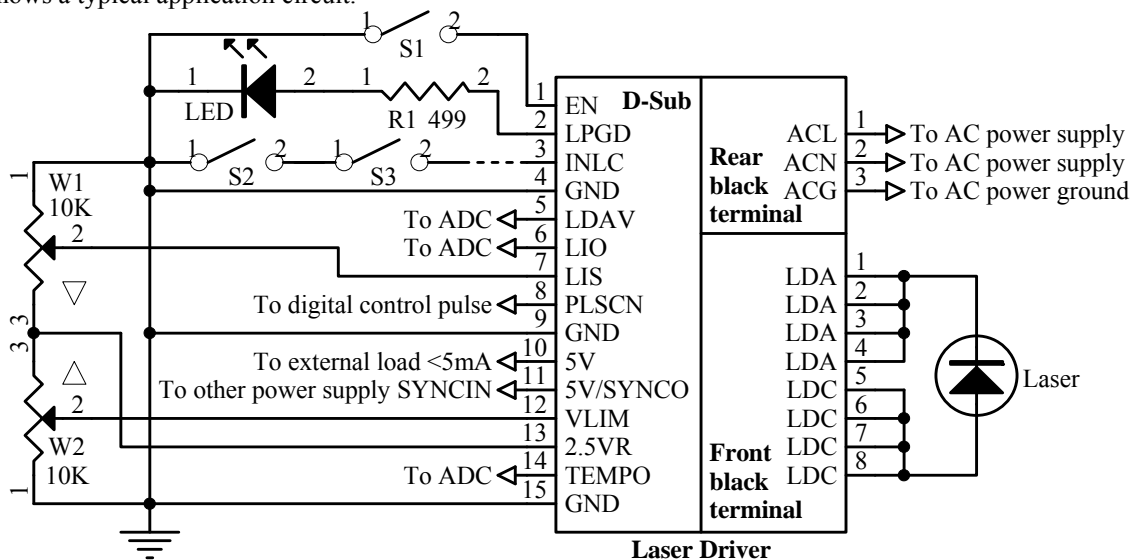

Figure 5. A Typical Application Schematic

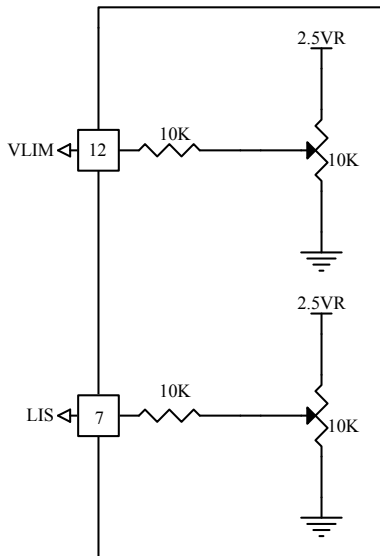

Figure 6. The internal circuits of VLIM and LIS

The output current and maximum output voltage can be set respectively by the internal two POTs (Potentiometers) on the front panel. These 2 parameters can also be set by 2 external POTs respectively as shown in Figure 5, while the internal POTs for setting the 2 parameters are over-riden. They can also be set by external analog signal sources, such as the output of a closed-looped op-amps, POTs, or DACs. The internal circuits for setting these 2 parameters are shown in Figure 6.

Depending on the particular circumstances, users do not necessarily apply external analog signals to VLIM and LIS nodes for setting the 2 parameters, relying on the 2 internal POTs is sufficient.

The output current can be set by the W1 in the schematic shown in Figure 5, maximum output voltage can be set by the potentiometer W2. The output current formula is:

$$I_{out} = 28 \times LIS \text{ (A)}$$

When VLIM voltage changes from 0V to 2.5V, the maximum output voltage is set to 1.3V to 6V linearly. The relationship is:

$$V_{max} = 2 \times VLIM + 1 \text{ (V)}$$

When VLIM voltage is set below 0.15V, the output voltage will stop changing and be clamped to 3.5V.

The maximum output voltage,  $V_{max}$ , is recommended to be 10% higher than the laser diode's maximum possible forward voltage. For example, when the forward voltage is of a laser diode 4V when powered by the 70A current, the maximum output voltage can thus be set to 4.4V.

The 2.5VR pin can be used as a 2.5V power supply, the

maximum output current is 20mA.

The LIO pin indicates the output current as:

$$\text{Output current} = 28 \times LIO \text{ (A)}$$

The module's temperature equation is:

$$\text{Temperature} = 72 \times \text{TEMPO} - 40 \text{ (}^\circ\text{C)}$$

When the TEMPO voltage changes from 0 to 2.5V, the temperature indicated is  $-40^\circ\text{C}$  to  $140^\circ\text{C}$ .

About the output signals on the LDA pins, the rise and fall times are about 40ms and 35ms respectively.

The SYNCO pin outputs pulses for synchronizing other switch-mode power supplies. This pulse represents the switching timing of the laser driver power circuit. The frequency is about 100 KHz, the duty cycle is about 50%, and the pulse voltage range is 0V to 16V with a 5K buffer resistor in series. The magnitude of the pulse varies with the output voltage and the current, but it is always higher than 3V, which can trigger most digital input ports.

The enable control pin, EN, is used for enabling the power supply. The logic threshold voltage is about 2V. When this pin is pulled down, the laser driver is disabled; otherwise, leaving this pin unconnected or pulling it up, the laser driver is enabled. There is a 12K pull-up resistor tied to a 5V power supply internally.

The LPGD pin indicates the laser drivers works properly when this pin goes high. It can be used for driving an LED directly and the maximum output current is 5mA.

The INLC pin is for connecting a series of interlock switches together. When any of these switches goes open, the laser driver stops outputting the current to the laser. The switches can be mounted on the lid of the final laser system, the enclosure panels, etc., detecting the opening of the lids or the panels, thus, preventing the laser beam from emitting out, endangering operators.

The PLSCN pin, the pulse mode control input node, is a digital input pin. It accepts a TTL or any digital signal and sets the output current to 0 when the PLSCN pin goes logic 0, and to the set-point current pre-set by the LIS pin, when the PLSCN pin goes to logic 1, respectively. The maximum pulsing frequency on this pin is 14 Hz.

On the input side, there are 3 pins. One of them is for the ground, ACG; the other 2 are for AC input port, the hot node, L pin, and the neutral node, N pin.

When the power is initially turned on, it may take 3 to 5 minutes for the power supply to reach the set-point current.



CAUTION

1. The VLIM of the laser driver ranges from 0V to 2.5V, and the corresponding LDA output ranges from 1.3V to 6V. In order to avoid the effect that the overshoot given to the laser diode, this power supply shouldn't drive only one laser diode, but two. If drive only one laser diode, the laser diode must be able to afford at least 3.3V 40ms overshoot.
2. Please take the anti-static measures, such as wrist straps, when handling the module so as not to damage the module.
3. Always connect the module's AC input with a proper cable in series with a switch and a plug, do not use stripped wires as the plug for connecting to the AC main socket. Make sure that the cable wires are firmly tighten by screw drivers onto the terminals to have reliable connections.
4. When making modifications on the connections, always turn off the power first.
5. Make sure that the polarity of the laser diode matches the polarity of the power supply's output.
6. Carefully and patiently check the application circuit. When you sure it is absolutely correct, you can turn on power supply. When the LED indicator light is lit up, it indicates that control loop is already stable.
7. To be on the safe side, we recommend using a dummy laser diode to replace the real laser diode first. The dummy diode can be composed of a serial of 4 to 6 regular high current diodes, such as 10A to 20A, and immerse the diodes into a cup of water. Use oscilloscope to look at the output waveform for checking the soft-start and soft-cut circuit. The output current can be measured by measuring the voltage across a low resistance value current sense resistor inserted into the circuit, and maximum output voltage can be measured by a volt meter by adjusting its value while keeping the output circuit open.
8. When modulating currents, high currents (30A~70A) need stabilized time for 3min~5min, the stabilized time of small current (0 ~30A) can be overlooked.
9. Customers should operate testing interface according to the datasheet to prevent ill effects.

NAMING

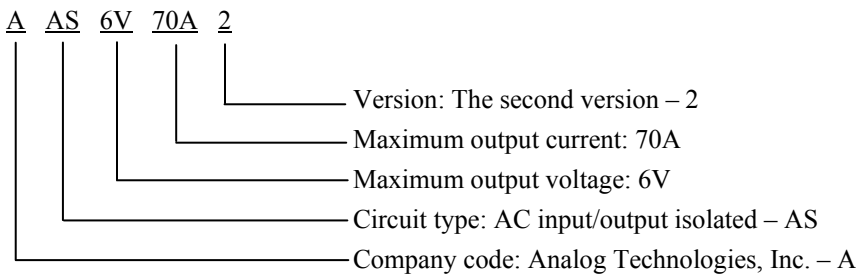

ORDERING INFORMATION

Table 3 Part Number

Part #	Description
AAS6V70A2	High efficiency AC input laser driver, I <sub>out_max</sub> = 70A, V <sub>out_max</sub> = 6V, Pin 11 = 5V.
AAS6V70A2SN	High efficiency AC input laser driver, I <sub>out_max</sub> = 70A, V <sub>out_max</sub> = 6V, Pin 11 = SYNCO.

Table 4 Unit Price

Quantity	1 – 9	10 – 49	50 – 249	250 – 499	≥500
AAS6V70A2	\$560.0	\$532.0	\$504.0	\$476.0	\$448.0
AAS6V70A2SN					



**NOTICE**

1. ATI warrants performance of its products for one year to the specifications applicable at the time of sale, except for those being damaged by excessive abuse. Products found not meeting the specifications within one year from the date of sale can be exchanged free of charge.
2. ATI reserves the right to make changes to its products or to discontinue any product or service without notice, and advise customers to obtain the latest version of relevant information to verify, before placing orders, that information being relied on is current and complete.
3. All products are sold subject to the terms and conditions of sale supplied at the time of order acknowledgment, including those pertaining to warranty, patent infringement, and limitation of liability. Testing and other quality control techniques are utilized to the extent ATI deems necessary to support this warranty. Specific testing of all parameters of each device is not necessarily performed, except those mandated by government requirements.
4. Customers are responsible for their applications using ATI components. In order to minimize risks associated with the customers' applications, adequate design and operating safeguards must be provided by the customers to minimize inherent or procedural hazards. ATI assumes no liability for applications assistance or customer product design.
5. ATI does not warrant or represent that any license, either express or implied, is granted under any patent right, copyright, mask work right, or other intellectual property right of ATI covering or relating to any combination, machine, or process in which such products or services might be or are used. ATI's publication of information regarding any third party's products or services does not constitute ATI's approval, warranty or endorsement thereof.
6. IP (Intellectual Property) Ownership: ATI retains the ownership of full rights for special technologies and/or techniques embedded in its products, the designs for mechanics, optics, plus all modifications, improvements, and inventions made by ATI for its products and/or projects.